

TECHNICAL BULLETIN

019

July 2017

CHECK VALVES for pumps XXT



1.904-196.0 (360477)



9.853-539.0 / 9.853-540.0

- The new pair of suction / delivery valves significantly improves the suction of the XXT
- The new pair of suction / discharge valves (12-19) is interchangeable with the old valve
- The kit "COMPLETE VALVE" part number 1.905-594.0 is just available

SUCTION DISCHARGE VALVE

XXT PUMP

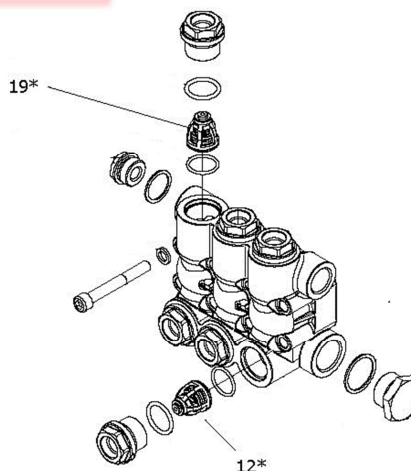
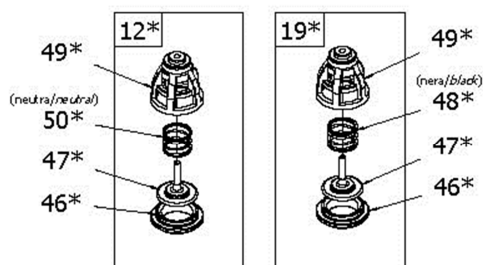

TECHNICAL BULLETIN

019

Luglio 2017

VALVOLE ASPIRAZIONE MANDATA per pompe XXT



1.904-196.0 (360477)



9.853-539.0 / 9.853-540.0

- *La nuova coppia di valvole aspirazione/mandata migliora sensibilmente l'aspirazione delle pompe XXT*
- *La nuova coppia di valvole aspirazione/mandata (12-19) è intercambiabile con la vecchia valvola*
- *Il kit "VALVOLA COMPLETA" codice 1.905-594.0 è già disponibile*

VALVOLE ASPIRAZIONE MANDATA

POMPA XXT

