

# XLT ES

Caratteristiche Tecniche

AISI 316

Technical Characteristics

Pump Pompa	Pressure Pressione		Volume Portata				RPM giri/min		Power Potenza			
			l/min		GPM				HP		kW	
	bar	PSI	50 Hz	60 Hz	50 Hz	60 Hz	50 Hz	60 Hz	50 Hz	60 Hz	50 Hz	60 Hz
XLT2520ESI	200	2900	25	30	6.6	7.9	1450	1740	13.1	15.7	9.6	11.5
XLT3020ESI	200	2900	30	36	7.9	9.5	1450	1740	15.7	18.8	11.5	13.9
XLT4020ESI	200	2900	40	48	10.6	12.7	1450	1740	20.9	25.1	15.4	18.5
XLT5620ESI	200	2900	56	67	14.7	17.6	1450	1740	29.3	35.2	21.5	25.9

Dimensioni d'ingombro

Overall dimensions

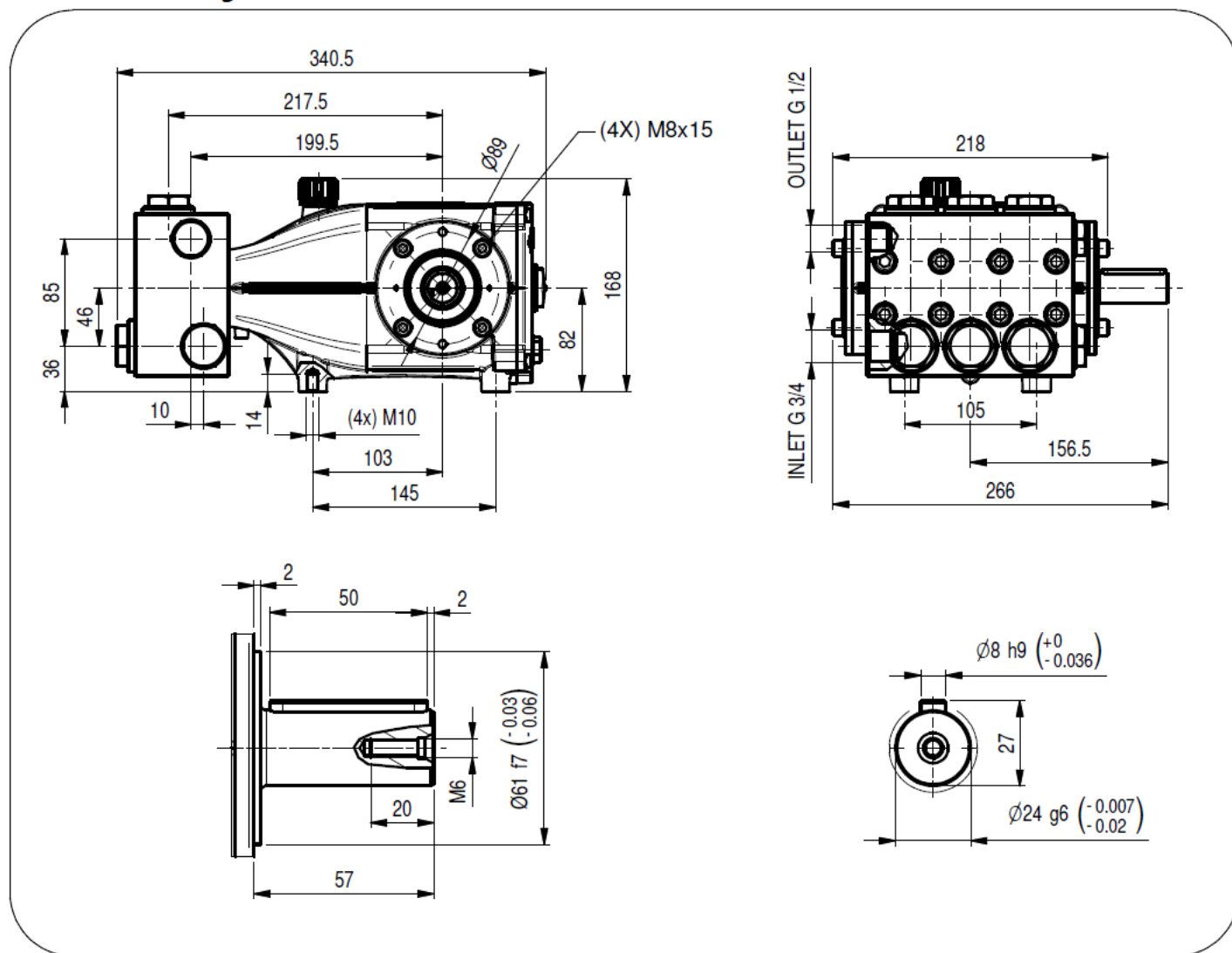

Lubrificazione: Olio SAE 10W40  
 Capacità: 1.2 Litri  
 Peso pompa: 19.5 kg

Lubrication: SAE 10W40 Oil  
 Capacity: 1.2 Litres  
 Weight: 19.5 kg

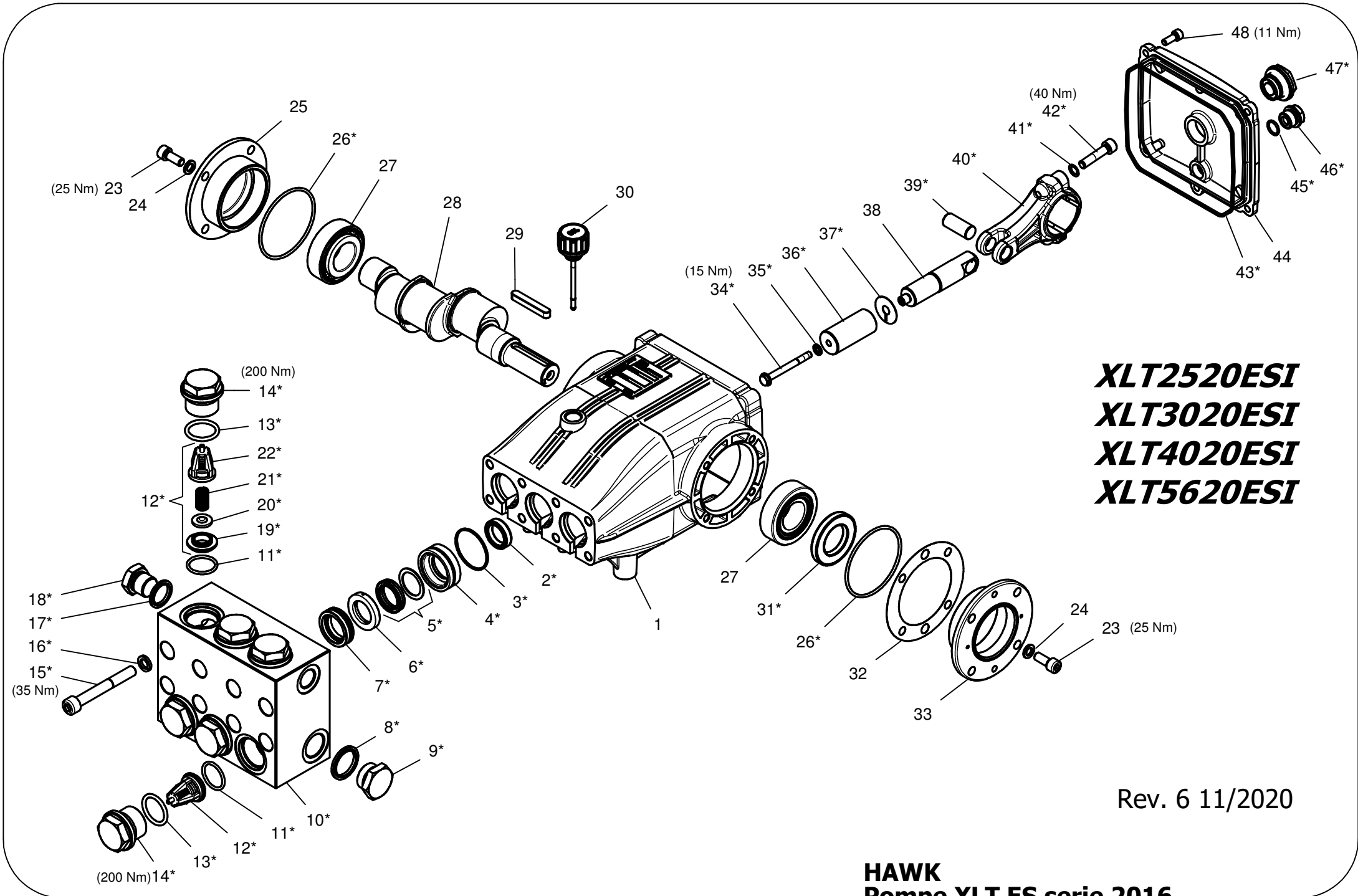

***XLT2520ESI***  
***XLT3020ESI***  
***XLT4020ESI***  
***XLT5620ESI***

Rev. 6 11/2020

**HAWK**  
**Pompe XLT ES serie 2016**  
**XLT ES pumps 2016 series**

## XLT ES 2016 SERIES

### ORDINARY MAINTENANCE KIT / KIT MANUTENZIONE ORDINARIA

KIT	Item Pos.	Part Number Codice	Description	Descrizione	Q.TY by Pump Q.TA per Pompa	XL T2520ESI	XL T3020ESI	XL T4020ESI	XL T5620ESI
A	3- 5- 7	1.904-464.0	PLUNGER SEALS DIA. 25 mm	GUARNIZIONI PISTONE Ø25	1	•	•	•	•
B	11- 12 (19- 20 21- 22) 13	1.905-719.0	COMPLETE VALVE	VALVOLA COMPLETA	1				

### EXTRAORDINARY MAINTENANCE KIT / KIT MANUTENZIONE STRAORDINARIA

KIT	Item Pos.	Part Number Codice	Description	Descrizione	Q.TY by Pump Q.TA per Pompa	XL T2520ESI	XL T3020ESI	XL T4020ESI	XL T5620ESI
C	3- 4- 5- 6- 7	1.905-694.0	COMPLETE SEALS PACKING DIA. 25 mm	PACCO COMPLETO GUARNIZIONI PISTONE Ø25	1				
D	34- 35- 36- 37	1.904-466.0	PLUNGER DIA. 25 mm	PISTONE Ø25	3				
E	2	1.099-766.0	PLUNGER OIL SEALS	ANELLI TENUTA OLIO ASTA	1				
F	26- 31- 43- 45 46- 47	1.905-613.0	KIT CRANKCASE SEALS	KIT TENUTE CARTER	1	•	•	•	•
G	3- 4- 5- 6- 7- 8 9- 10- 11- 12 (19- 20 21- 22) 13- 14- 15- 16 17- 18	1.904-468.0	COMPLETE MANIFOLD 25	TESTATA COMPLETA Ø25	1				
H	34-35-38-39- 40-41-42	1.905-715.0	CONNECTING ROD PLUNGER ROD ASSY	PREMONTATO ASTA-BIELLA-PISTONE	3				
I	13- 14	1.904-329.0	VALVE PLUG ASSY	PREMONTATO TAPPO VAM	1				

“Q.TY by Pump” => Necessary quantity to repair one pump  
 “Q.TA’ per Pompa” => Quantità necessaria per riparare una pompa

## TOOL KIT

<i>Part Number Codice</i>	<i>Description</i>	<i>Descrizione</i>	<i>Q.TY by Pump Q.TA per Pompa</i>	<i>XLT2520ESI</i>	<i>XLT3020ESI</i>	<i>XLT4020ESI</i>	<i>XLT5620ESI</i>
1.099-665.0	TOOL-KIT	TOOL-KIT	1				
1.905-659.0	OIL SEAL EXTRACTOR TOOL-KIT	TOOL-KIT ESTR. PARAOLIO	1	•	•	•	•
1.099-963.0	ADDITIONAL TOOL KIT	TOOL KIT ADDIZIONALE	1				

### **IMPORTANT**

### **IMPORTANTE**

\* *Part available ONLY in kit*  
Disponibile SOLO in kit

(...) **Parts pre-assembled**  
**Parti pre-assemblate**

### PARTS LIST LISTA PARTI

Item Pos	Part Number Codice	Description	Descrizione	KIT	Q.TY Q.TA	XL72520ESI	XL73020ESI	XL74020ESI	XL75620ESI
1	9.850-377.0	CRANKCASE	CARTER		1				
2*		PLUNGER OIL SEAL	ANELLO RADIALE	E	3				
3*		"O" RING Ø1.78X37.82	"O" RING Ø1.78X37.82	A-C-G	3				
4*		PRESSURE RING 25MM	PRESSORE "U" Ø25	C-G	3				
5*		LOW PRESSURE "U" SEAL, DIA.25MM	ANELLO TENUTA "U" Ø25	A-C-G	3				
6*		INTERMED. RING 25MM	DIFFUSORE INTER. Ø25	C-G	3				
7*		HIGH PRESSURE "U" SEAL, DIA.25MM	ANELLO TENUTA "U" Ø25	A-C-G	3				
8*		BONDED SEAL STAINLESS STEEL G3/4	BONDED SEAL G3/4 INOX	G	1				
9*		STAINLESS STEEL PLUG G3/4	TAPPO G3/4 INOX	G	1				
10*		MANIFOLD HOUSING	TESTATA	G	1				
11*		"O" RING Ø2.62X25.07	"O" RING Ø2.62X25.07	B-G	6				
12*		VALVE ASSEMBLY	VALVOLA PREMONTATA	B-G	6				
13*		"O" RING Ø2.62X26.58	"O" RING Ø2.62X26.58	B-G-I	6				
14*		STAINLESS STEEL VALVE PLUG	TAPPO VALVOLA INOX	G-I	6				
15*		MANIFOLD STUD BOLT STAINLESS STEEL	VITE TCEI M10X80 INOX A2-70	G	8				
16*		LOCK WASHER STAINLESS STEEL	ROSETTA ELASTICA Ø10,2 INOX	G	8				
17*		BONDED SEAL STAINLESS STEEL G1/2	BONDED SEAL G1/2 INOX	G	1				
18*		STAINLESS STEEL PLUG G1/2	TAPPO G1/2 INOX	G	1				
19*		VALVE SEAT	SEDE VALVOLA	B-G	6				
20*		VALVE PLATE	PIATTELLO VALVOLA	B-G	6				
21*		VALVE SPRING	MOLLA VALVOLA	B-G	6				
22*		VALVE CAGE	GABBIA VALVOLA	B-G	6				
23	9.851-476.0	SCREW M8X20 STAINLESS STEEL	VITE TCEI M8X20 INOX		8				
24	9.851-133.0	LOCK WASHER STAINLESS STEEL	ROSETTA ELASTICA Ø10,2 INOX		8				
25	9.850-620.0	CLOSED BEARING HOUSING	FLANGIA CHIUSA		1				
26*		"O" RING Ø2.62X71.12	"O" RING Ø2.62X71.12	F	2				
27	9.850-347.0	ROLLER BEARING	CUSCINETTO A RULLI		2				
28	9.850-193.0	CRANKSHAFT DIA. 24 MM	ALBERO Ø24		1				
	9.850-194.0	" " " "	" "						
	9.850-195.0	" " " "	" "						
	9.850-222.0	" " " "	" "						
29	9.850-447.0	CRANKSHAFT KET	CHIAVETTA		1				
30	9.851-287.0	OIL DIP STICK	TAPPO LIVELLO OLIO		1				
31*		CRANKSHAFT SEAL	ANELLO RADIALE	F	1				
32	9.850-546.0	SHIM	DISTANZIALE		1				
33	9.850-610.0	BEARING HOUSING	FLANGIA APERTA		1				
34*		PLUNGER BOLT	VITE PISTONE	D-H	3				
35*		BONDED SEAL	BONDED SEAL	D-H	3				
36*		PLUNGER DIA. 25 MM	PISTONE Ø25	D	3				

Item Pos	Part Number Codice	Description	Descrizione	KIT	Q.TY Q.T. A	XL T2920ESI	XL T3020ESI	XL T4020ESI	XL T5620ESI
37*		STAINLESS STEEL SPACER	ROSETTA INOX	D	3				
38*		PLUNGER ROD	ASTA PISTONE	H	3				
39*		CONNECTING ROD PIN	SPINOTTO	H	3				
40*		CONNECTING ROD	BIELLA	H	3				
41*		SPRING WASHER	ROSETTA ELASTICA Ø8	H	6				
42*		CONNECTING ROD SCREW	VITE BIELLA	H	6				
43*		"O" RING Ø2.62X152.07	"O" RING Ø2.62X152.07	F	1	•	•	•	•
44	9.850-389.0	CRANKCASE COVER	COPERCHIO		1				
45*		"O" RING Ø1.78X14.00	"O" RING Ø1.78X14.00	F	1				
46*		BRASS PLUG G 3/8	TAPPO OTTONE G 3/8	F	1				
47*		SIGHT GLASS, G 3/4	SPIA LIVELLO OLIO	F	1				
48	9.851-475.0	COVER SCREW STAINLESS STEEL	VITE M6X16 INOX		5				