

Pump Pompa	Pressure Pressione		Volume Portata				RPM giri/min		Power Potenza			
			l/min		GPM				HP		kW	
	bar	PSI	50 Hz	60 Hz	50 Hz	60 Hz	50 Hz	60 Hz	50 Hz	60 Hz	50 Hz	60 Hz
GXT1015SHT	150	2175	100	120	25,8	31	1000	1200	38,0	45,6	28,0	33,6
GXT1215SHT	150	2175	120	144	31,3	37,6	1000	1200	46,5	55,8	34,2	41,0
GXT1513SHT	130	1885	150	180	39,2	47	1000	1200	50,6	60,7	37,2	44,6
GXT1711SHT	110	1595	170	204	44,9	53,9	1000	1200	47,5	57,0	35,0	42,0

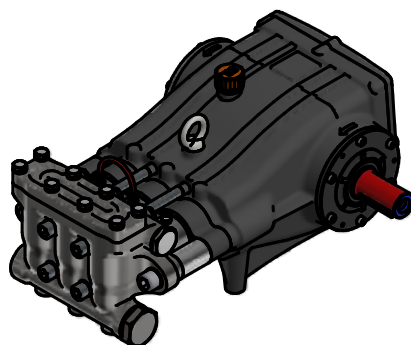

Dimensioni d'ingombro

Overall dimensions

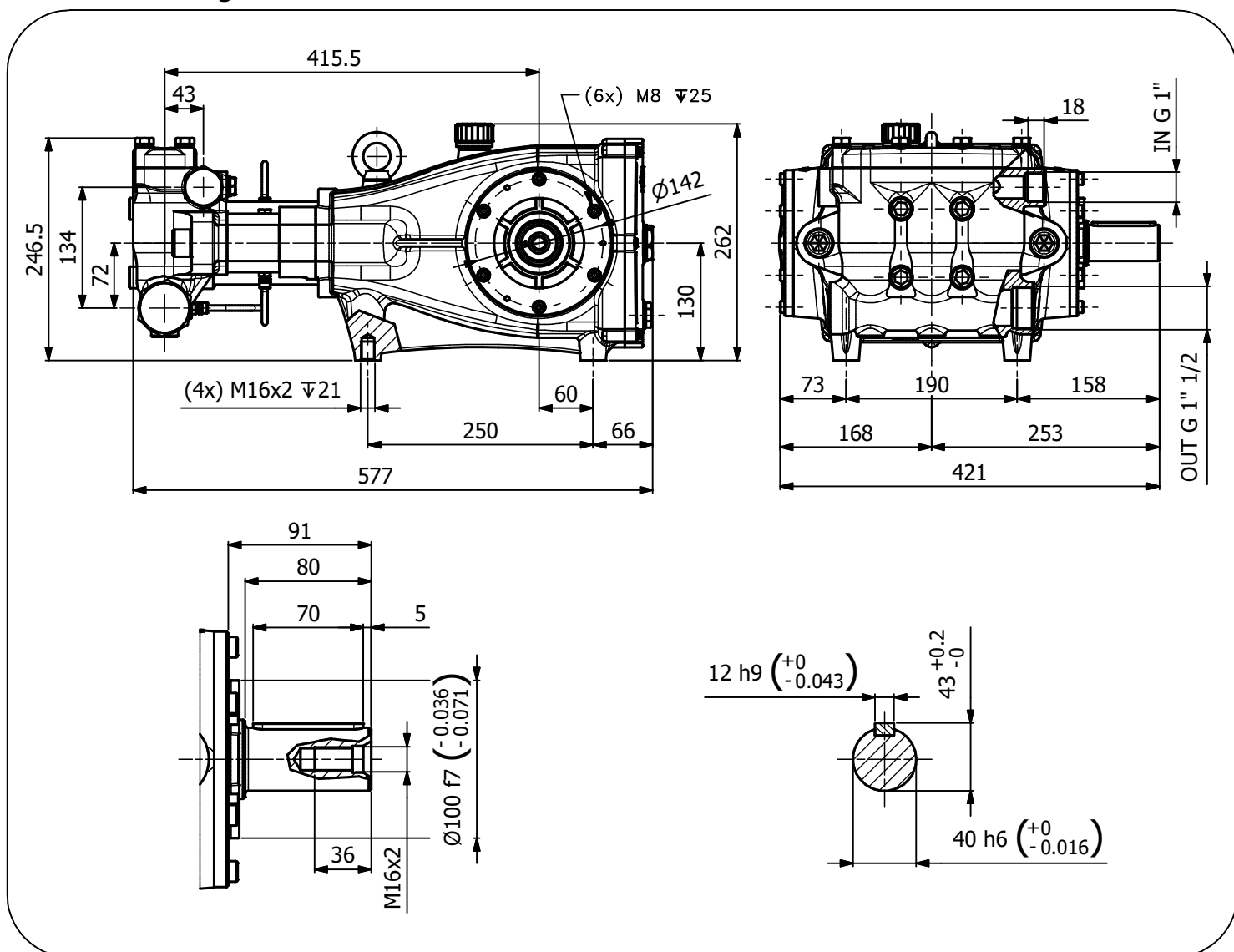

(\*) disponibili solo in kit  
available only in kit

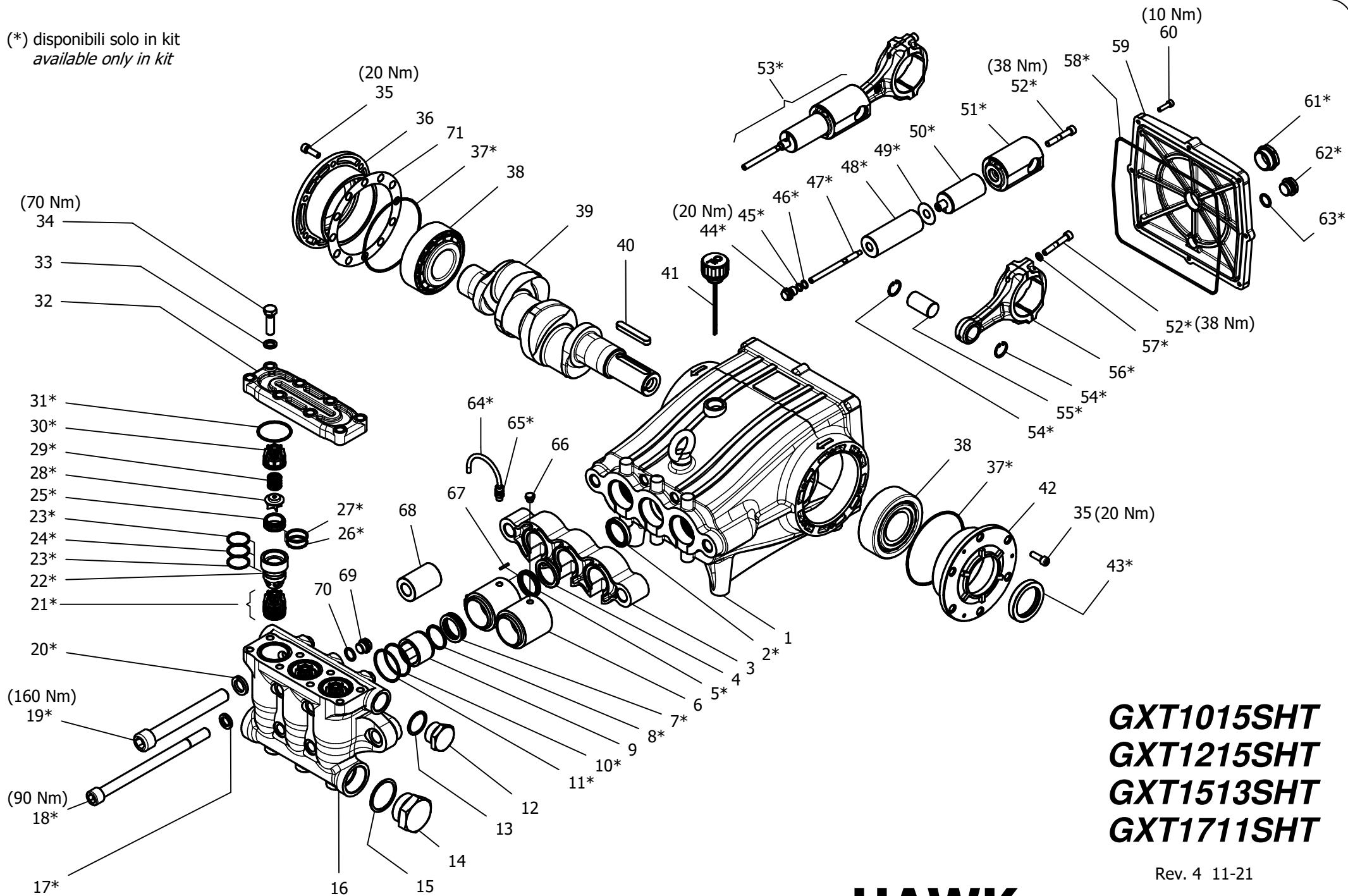

**GXT1015SHT**  
**GXT1215SHT**  
**GXT1513SHT**  
**GXT1711SHT**

Rev. 4 11-21

**HAWK**  
**serie GXT HT 2017**

## GXT HT SERIES 2017

### MAINTENANCE KIT / KIT MANUTENZIONE

KIT	Item - Pos	Part Number - Codice	Description	Descrizione	Q.TY per pump - Q.TA' per pompa	GXT1015SHT	GXT1215SHT	GXT1513SHT	GXT1711SHT
A	5- 7- 8- 9- 10- 11	9.853-354.0	PISTON SEAL PACKING Ø36	GUARNIZIONI PISTONE Ø36	1				
B	43- 44- 45- 47- 49	1.904-473.0	PLUNGER Ø36	PISTONE Ø36	3				
C	37- 43- 58- 61 62- 63	1.904-474.0	KIT CRANCKASE SEALS	KIT TENUTE CARTER	1	•	•	•	•
D	17- 18- 19- 20	1.904-472.0	MANIFOLD SCREWS	VITI TESTATA	1				
E	44- 45- 46- 49- 52 53- 54- 55- 56- 57	1.904-475.0	PLUNGER ROD-CONNECTING ROD	ASTA PISTONE-BIELLA	3	•	•		
		1.904-879.0	PLUNGER ROD-CONNECTING ROD	ASTA PISTONE-BIELLA	3			•	•
F	64- 65	1.904-477.0	COMPLETE CIRCULATION PIPES	TUBI RICIRCOLO	1				
G	21 (25- 26- 27- 28 29- 30) 22- 23 24- 31	1.904-470.0	COMPLETE VALVE	VALVOLE COMPLETE	1	•	•	•	•
H	21 (25- 26- 27 28- 29- 30) 23 24- 31	1.904-471.0	VALVE	VALVE	1				
I	2	1.904-478.0	PLUNGER OIL SEALS	TENUTE OLIO ASTA PISTONE	1				

“Q.TY per pump” => Necessary quantity to repair one pump  
 “Q.TA’ per pompa” => Quantità necessaria per riparare una pompa

#### IMPORTANT

#### IMPORTANTE

\* Part available **ONLY** in kit  
 Disponibile **SOLO** in kit

(...) Parts pre-assembled  
 Parti pre-assemblate

### PARTS LIST LISTA PARTI

Item Pos	Part Number Codice	Description	Descrizione	Kit	Q.TY Q.TA	GXT1020SHT	GXT1215SHT	GXT1515SHT	GXT1712SHT
1	9.853-880.0	CRANCKCASE	CARTER		1				
2*		OIL SEAL HNBR	ANELLO RADIALE HNBR	I	3				
3	9.850-361.0	SPACER	DISTANZIALE CARTER		1				
4	9.851-930.0	SUPPORT RING Ø36	PRESSORE Ø36		3				
5*		"U" LP SEAL HT Ø36	TENUTA BASSA PRESSIONE HT Ø36	A	3				
6	9.853-380.0	INTERMEDIATE RING Ø36	DIFFUSORE Ø36		3				
7*		"U" HP SEAL HT Ø36	TENUTA ALTA PRESSIONE HT Ø36	A	3				
8*		SCRAPER Ø36	RASCHIATORE PISTONE Ø36	A	3				
9*		BUSH GUIDE Ø36	BOCCOLA GUIDA Ø36	A	3				
10*		BACK RING OR3200	ANELLO ANTIESTR. OR3200	A	3				
11*		O-RING 3200 – NBR90	O-RING 3200 – NBR90	A	3				
12	9.851-356.0	PLUG G1"	TAPPO G1"		1				
13	9.850-752.0	COPPER WASHER G1"	GUARNIZIONE G1"		1				
14	9.853-383.0	PLUG G1" 1/2	TAPPO G1" 1/2		1				
15	9.850-753.0	COPPER WASHER G1" ½	GUARNIZIONE G1" 1/2		1				
16	9.853-384.0	MANIFOLD	TESTATA		1				
17*		WASHER M16	ROSETTA M16	D	4				
18*		SCREW M16x240	VITE TCEI M16x240	D	4				
19*		SCREW M20x170	VITE TCEI M20x170	D	2	•	•	•	•
20*		WASHER M20	ROSETTA M20	D	2				
21*		VALVE ASSEMBLY	PREMONATATO VALVOLA	G - H	6				
22*		VALVE SPACER	DISTANZIALE VALVOLA	G	3				
23*		BACK RING OR3118	ANELLO ANTIESTR. OR3118	G - H	6				
24*		O-RING 3118 – NBR90	O-RING 3118 – NBR90	G - H	3				
25*		VALVE SEAT	SEDE VALVOLA	G - H	6				
26*		BACK RING OR3112	ANELLO ANTIESTR. OR3112	G - H	6				
27*		O-RING 3112 – NBR90	O-RING 3112 – NBR90	G - H	6				
28*		VALVE PLATE	PIATTELLO VALVOLA	G - H	6				
29*		SPRING	MOLLA	G - H	6				
30*		VALVE CAGE	GABBIA VALVOLA	G - H	6				
31*		O-RING 3193 – NBR90	O-RING 3193 – NBR90	G - H	3				
32	9.853-378.0	MANIFOLD COVER	COPERCHIO TESTATA		1				
33	9.851-140.0	WASHER M12	ROSETTA M12		8				
34	9.851-518.0	SCREW M12x40	VITE TE M12x40		8				
35	9.851-468.0	SCREW M8x25	VITE TCEI M8x25		12				
36	9.850-646.0	CLOSED HOUSING	FLANGIA CHIUSA		1				
37*		O-RING 3475 – NBR70	O-RING 3475 – NBR70	C	2				

Item Pos	Part Number Codice	Description	Descrizione	Kit	Q.TY Q.TÀ	GXT1020SHT	GXT1215SHT	GXT1515SHT	GXT1712SHT
38	9.850-353.0	BEARING	CUSCINETTO		2	•	•	•	•
39	9.853-844.0	CRANKSHAFT "1"	ALBERO "1"		1				•
	9.851-915.0	CRANKSHAFT "B"	ALBERO "B"		1	•			
	9.853-097.0	CRANKSHAFT "E"	ALBERO "E"		1		•		
	9.853-845.0	CRANKSHAFT "3"	ALBERO "3"		1			•	
40	9.850-449.0	CRANKSHAFT KEY	CHIAVETTA		1				
41	9.851-284.0	OIL DIP STICK G3/4	TAPPO SFIATO OLIO G3/4		1				
42	9.850-645.0	BEARING HOUSING	FLANGIA APERTA		1				
43*		OIL SEAL	ANELLO RADIALE	C	1				
44*		PLUNGER NUT	DADO PISTONE	B - E	3				
45*		O-RING 2037 - NBR70	O-RING 2037 - NBR70	B - E	3				
46*		BACK RING OR2037	ANELLO ANTIESTR. OR2037	B - E	3				
47*		PLUNGER SCREW	TIRANTE PISTONE	E	3				
48*		PLUGER Ø36	PISTONE Ø36	B	3	•	•	•	•
49*		PLUGER WASHER	ROSETTA PISTONE	B - E	3				
50*		PLUNGER ROD SPACER	DISTANZIALE ASTA	E	3				
51*		PLUNGER ROD	ASTA PATTINO	E	3				
52*		SCREW M8x50	VITE TCEI M8x50	E	9				
53*		ASSEMBLY PLUNGER ROD	PREMONATATO ASTA PISTONE	E	3				
54*		SEEGER	ANELLO SEEGER	E	6				
55*		CONNECTING ROD PIN	SPINOTTO	E	3				
56*		CONNECTING ROD	BIELLA	E	3	•	•		
		CONNECTING ROD	BIELLA	E	3			•	•
57*		WASHER M8	ROSETTA ELASTICA M8	E	6				
58*		O-RING Ø2,62x255 - NBR90	O-RING Ø2,62x255 - NBR90	C	1				
59	9.850-395.0	CRANCKCASE COVER	COPERCHIO CARTER		1				
60	9.851-480.0	SCREW M6x22	VITE TCEI M6x22		8				
61*		SIGHT GLASS G1"	SPIA LIVELLO G1"		1				
62*		PLUG G1/2	TAPPO G1/2	C	1				
63*		O-RING 3068 - NBR70	O-RING 3068 - NBR70	C	1				
64*		RED RILSAN PIPE 6/4	TUBO RILSAN 6/4 ROSSO	F	3	•	•	•	•
65*		FITTING G1/8-6/4	RACCORDO G1/8-6/4	C	6				
66	9.851-353.0	PLUG G1/8	TAPPO G1/8		1				
67	9.851-256.0	PIN	SPINA CILINDRICA		3				
68	9.853-875.0	NICKEL PLATED SPACER	DISTANZIALE TESTATA NICHELATO		2				
69	9.851-346.0	PLUG G3/8	TAPPO G3/8		3				
70	9.850-747.0	COPPER WASHER G3/8	GUARNIZIONE RAME G3/8		3				
71	9.850-549.0	SHIM	DISTANZIALE FLANGIA		1				