

Caratteristiche Tecniche

NHDP F NEMA

Technical Characteristics

Pump Pompa	Pressure Pressione		Volume Portata		RPM giri/min	Power Potenza	
	bar	PSI	l/min	GPM		HP	kW
NHDP2030FNE		3000		2.0	3450	3.5	2.6
NHDP3530FNE		3000		3.5	3450	6.8	5.0

Dimensioni d'ingombro

Overall dimensions

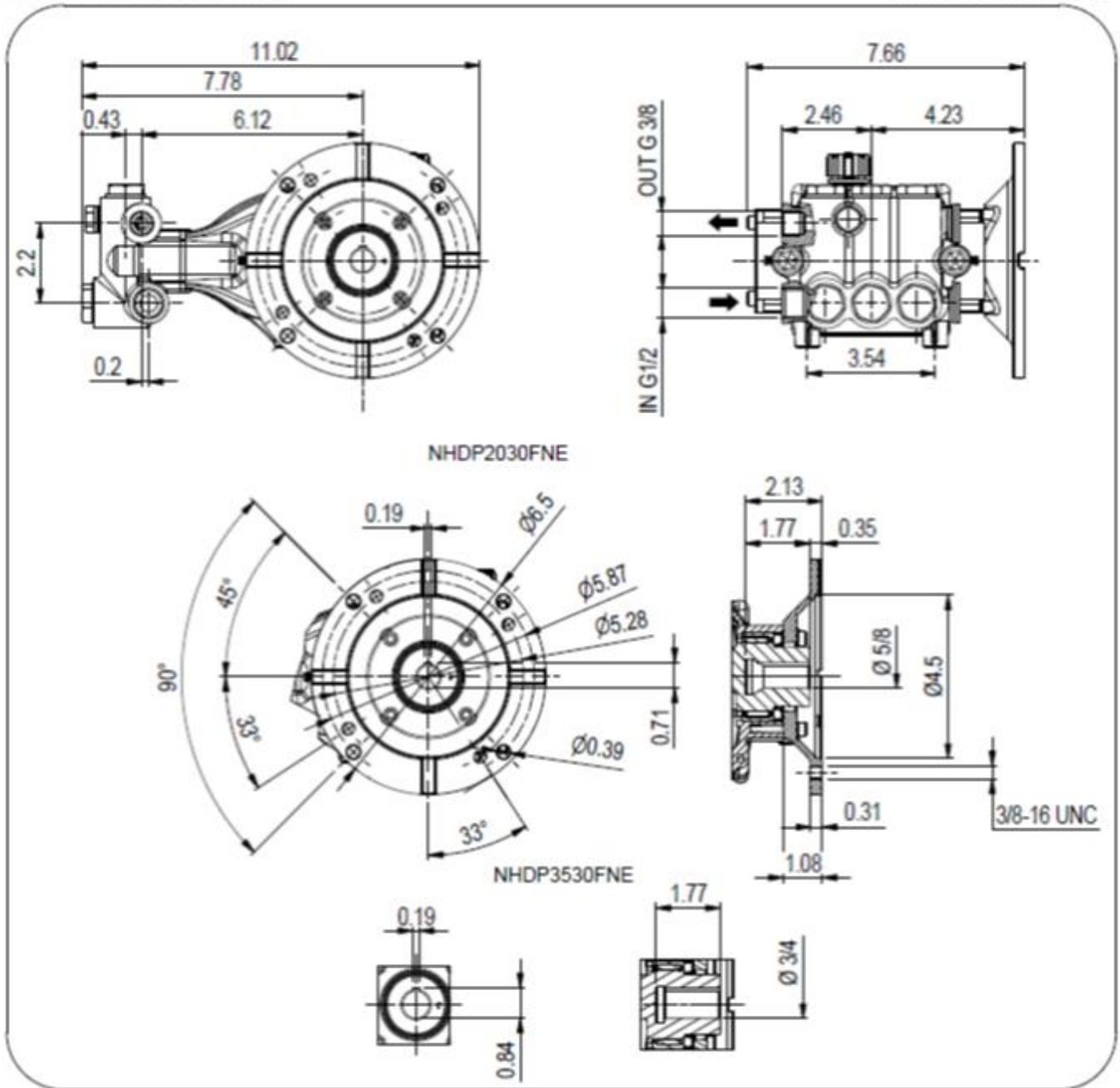

Lubrificazione: Olio SAE 10W40
 Capacità: 0.5 Litri
 Peso pompa: 8.4 kg

Lubrication: SAE 10W40 Oil
 Capacity: 0.5 Litres
 Weight: 8.4 kg

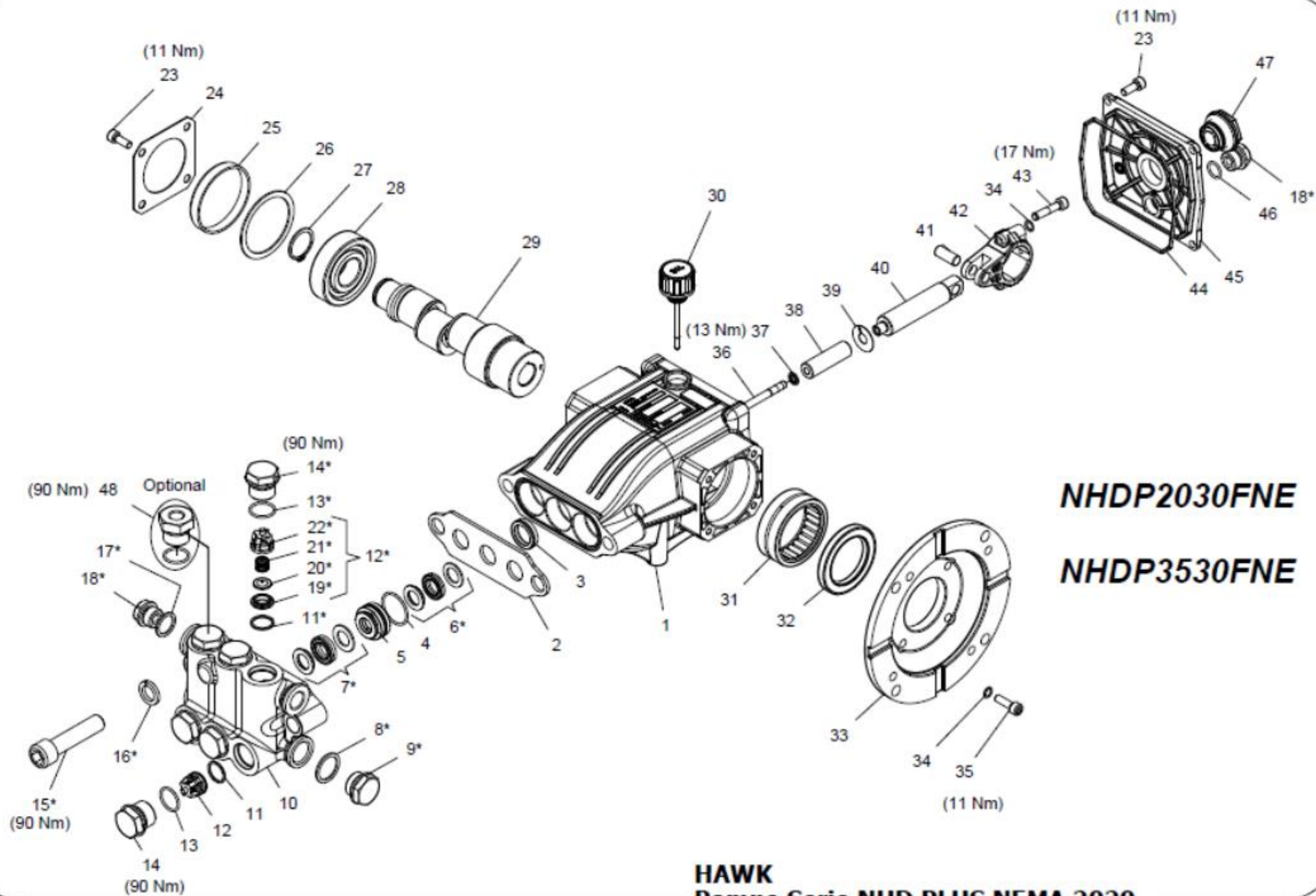

NHDP2030FNE

NHDP3530FNE

HAWK
Pompe Serie NHD PLUS NEMA 200
NEMA NHD PLUS Pumps 2020 Serie

NHDP F NEMA 2020 SERIES

ORDINARY MAINTENANCE KIT / KIT MANUTENZIONE ORDINARIA

KIT	Item Pos.	Part Number Codice	Description	Descrizione	Q.TY by Pump Q.TA per Pompa	NHDP2030FNE	NHDP3530FNE
A	4- 6 – 7- 15	1.904-743.0	PLUNGER SEALS DIA. 14 mm	GUARNIZIONI PISTONE Ø14	1		
B	11 - 12 (19 – 20 - 21- 22) - 13	1.905-617.0	COMPLETE VALVE	VALVOLA COMPLETA	1	•	•

EXTRAORDINARY MAINTENANCE KIT / KIT MANUTENZIONE STRAORDINARIA

KIT	Item Pos.	Part Number Codice	Description	Descrizione	Q.TY by Pump Q.TA per Pompa	NHDP2030FNE	NHDP3530FNE
C	4- 5- 6 - 7 - 15 - 16	1.904-741.0	COMPLETE SEALS PACKING DIA. 14 mm	PACCO COMPLETO GUARNIZIONI PISTONE Ø14	1		
D	36 - 37- 38- 39	1.099-833.0	PLUNGER DIA. 14 mm	PISTONE Ø14	3		
E	3	1.099-740.0	PLUNGER OIL SEALS	ANELLI TENUTA OLIO ASTA	1		
F	18- 25 – 32 - 44 - 46- 47	1.905-622.0	KIT CRANKCASE SEALS	KIT TENUTE CARTER	1	•	•
G	4- 5- 6- 7- 8- 9- 10- 11- 12 (19 – 20 - 21- 22) – 13 – 14 - 15- 16 - 17- 18	1.904-742.0	COMPLETE MANIFOLD	TESTATA COMPLETA	1		
H	34 - 40 - 41- 42- 43	1.905-742.0	CONNECTING ROD PLUNGER ROD ASSY	PREMONTATO ASTA-BIELLA PISTONE	3		
I	13- 14	1.904-249.0	VALVE PLUG ASSY	PREMONTATO TAPPO VAM	6		

“Q.TY by Pump” => Necessary quantity to repair one pump
“Q.TA’ per Pompa” => Quantità necessaria per riparare una pompa

OPTIONAL

Item Pos.	Part Number Codice	Description	Descrizione	Q.TY by Pump Q.TA per Pompa	NHDP2030FNE	NHDP3530FNE
48	9.853-424.0	THREADED BRASS PLUG G1/4	PREMONTATO TAPPO FORATO	1	•	•

TOOL KIT

Part Number Codice	Description	Descrizione	Q.TY by Pump Q.TA per Pompa	NHDP2030FNE	NHDP3530FNE
1.099-668.0	TOOL-KIT	TOOL-KIT	1	•	•
1.905-591.0	OIL SEAL EXTRACTOR TOOL-KIT	TOOL-KIT ESTR. PARAOLIO	1		

IMPORTANT

IMPORTANTE

* **Part available ONLY in kit**
Disponibile SOLO in kit

(...) **Parts pre-assembled**
Parti pre-assemblate

PARTS LIST LISTA PARTI

Item Pos	Part Number Codice	Description	Descrizione	KIT	Q.TY Q.TA	NHDP2030FNE	NHDP3530FNE
1	9.850-369.0	CRANKCASE	CARTER		1		
2*	9.853-555.0	NHD PLUS CYLINDERHEAD SPACER	DISTANZIALE TESTATA NHD PLUS		1		
3*		PLUNGER OIL SEAL	ANELLO RADIALE	E	3		
4*		"O" RING Ø1.78X26.7	"O" RING Ø1.78X26.7	A-C-G	3		
5*		PRESURE RING Ø14	PRESSORE Ø14	A-C-G	3		
6*		SEALING RING PIST. Ø14X22X8 "U"	ANELLO TEN. PIST. Ø14X22X8 "U"	C-G	3		
7*		SEALING RING PIST. Ø14X24X9 "U"	ANELLO TEN. PIST. Ø14X24X9 "U"	A-C-G	3		
8*		COPPER WASHER G1/2	GUARNIZIONE RAME G1/2	G	1		
9*		BRASS PLUG G1/2	TAPPO OTTONE G1/2	G	1		
10*		CYLINDERHEAD NHD PLUS OT58 D.14	TESTATA NHD PLUS OT58 D.14	G	1		
11*		"O" RING Ø1.78X15.6	"O" RING Ø1.78X15.6	B-G	6		
12*		VALVE ASSEMBLY	VALVOLA PREMONTATA	B-G	6		
13*		"O" RING Ø1,78X18.77	"O" RING Ø1.78X18.77	B-G-I	6		
14*		VALVE PLUG	TAPPO VALVOLA	G-I	6		
15*		MANIFOLD STUD BOLT M14X60	VITE TCEI M14X60	A-C-G	2		
16*		LOCK-WASHER	ROSETTA ELASTICA Ø14	G	2		
17*		COPPER WASHER G3/8	GUARNIZIONE RAME G 3/8	G	1		
18*		BRASS PLUG G 3/8	TAPPO OTTONE G 3/8	F-G	2		
19*		VALVE SEAT	SEDE VALVOLA	B-G	6		
20*		VALVE PLATE	PIATTELLO VALVOLA	B-G	6		
21*		VALVE SPRING	MOLLA VALVOLA	B-G	6		
22*		VALVE CAGE	GABBIA VALVOLA	B-G	6		
23	9.851-474.0	SCREW M6X16	VITE TCEI M6X16		8		
24	9.850-379.0	BEARING COVER	COPERCHIO CUSCINETTO		1		
25*		BEARING SEAL	CAPPELLOTTO CUSCINETTO	F	1		
26	9.850-554.0	CRANKSHAFT SEAL SPACER	DISTANZIALE PARAOLIO ALBERO		1		
27	9.851-198.0	SNAP RING DIA. 25 MM	ANELLO Ø25		1		
28	9.850-460.0	BALL BEARING	CUSCINETTO A SFERE		1		
29	9.850-252.0	HOLLOW SHAFT	ALBERO CAVO		1		
	9.850-256.0	" "	" "		1		
30	9.851-286.0	OIL DIP STICK	TAPPO LIVELLO OLIO		1		
31	9.850-354.0	NEEDEL ROLLER BEARING	CUSCINETTO A RULLINI		1		
32*		CRANKSHAFT SEAL	ANELLO RADIALE	F	1		
33	9.850-637.0	MOTOR FLANGE	FLANGIA MOTORE		1		
34	9.851-151.0	SPRING WASHER DIA. 6 MM	ROSETTA SCHNORR Ø6		10		
35	9.851-491.0	SCREW M6X20	VITE TCEI M6X20		4		
36*		PLUNGER BOLT	VITE PISTONE	D	3		

Item Pos	Part Number Codice	Description	Descrizione	KIT	Q.TY Q.TÀ	NHDP2030FNE	NHDP3530FNE
37*		BONDED SEAL - Ø6,7X11X1 AISI 304	BONDED SEAL - Ø6,7X11X1 AISI 304	D	3		
38*		PLUNGER DIA. 14 MM	PISTONE Ø14	D	3		
39*		COPPER SPACER	ROSETTA RAME	D	3		
40*		PLUNGER ROD	ASTA PISTONE	E	3		
41*		CONNECTING ROD PIN	SPINOTTO	E	3		
42*		CONNECTING ROD	BIELLA	E	3	•	•
43*		CONNECTING ROD SCREW	VITE M6X30	E	6		
44*		"O" RING Ø2.62X111.62	"O" RING Ø2.62X111.62	F	1		
45	9.850-392.0	CRANKCASE COVER	COPERCHIO POSTERIORE		1		
46*		"O" RING Ø1.78X14	"O" RING Ø1.78X14	F	1		
47*		SIGHT GLASS G3/4	SPIA LIVELLO OLIO G3/4	F	1		