

Pump Pompa	Pressure Pressione		Volume Portata				RPM giri/min		Power Potenza			
			l/min		GPM				HP		kW	
	bar	PSI	50 Hz	60 Hz	50 Hz	60 Hz	50 Hz	60 Hz	50 Hz	60 Hz	50 Hz	60 Hz
XLT2515ESA	150	2175	25	30	6.6	7.9	1450	1740	9.8	11.8	7.2	8.7
XLT3015ESA	150	2175	30	36	7.9	9.5	1450	1740	11.8	14.1	8.7	10.4
XLT3515ESA	150	2175	35	42	9.2	11	1450	1740	13.7	16.5	10.1	12.1
XLT4015ESA	150	2175	40	48	10.6	12.7	1450	1740	15.7	18.8	11.5	13.8
XLT5015ESA	150	2175	50	60	13.2	15.8	1450	1740	19.6	23.5	14.4	17.3

Dimensioni d'ingombro

Overall dimensions

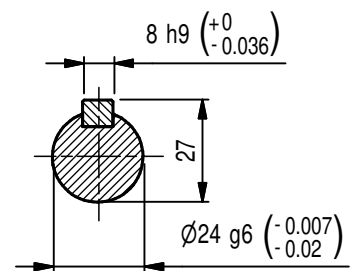

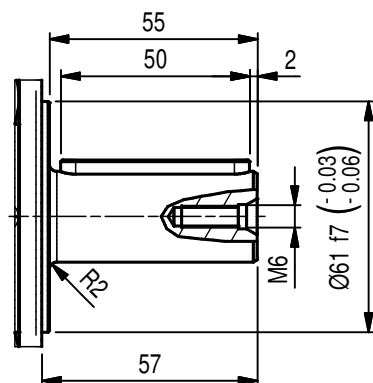
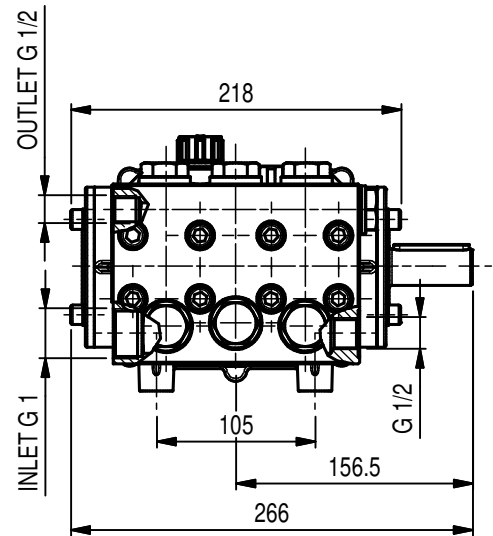
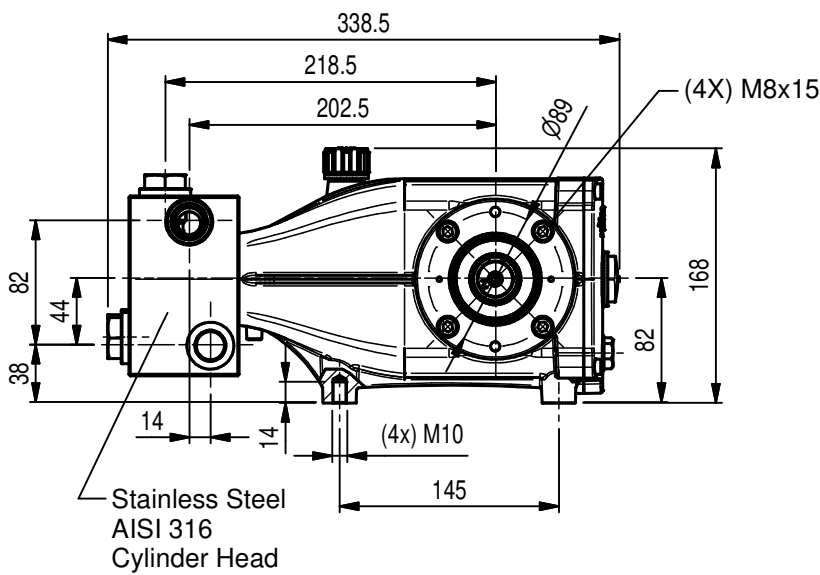
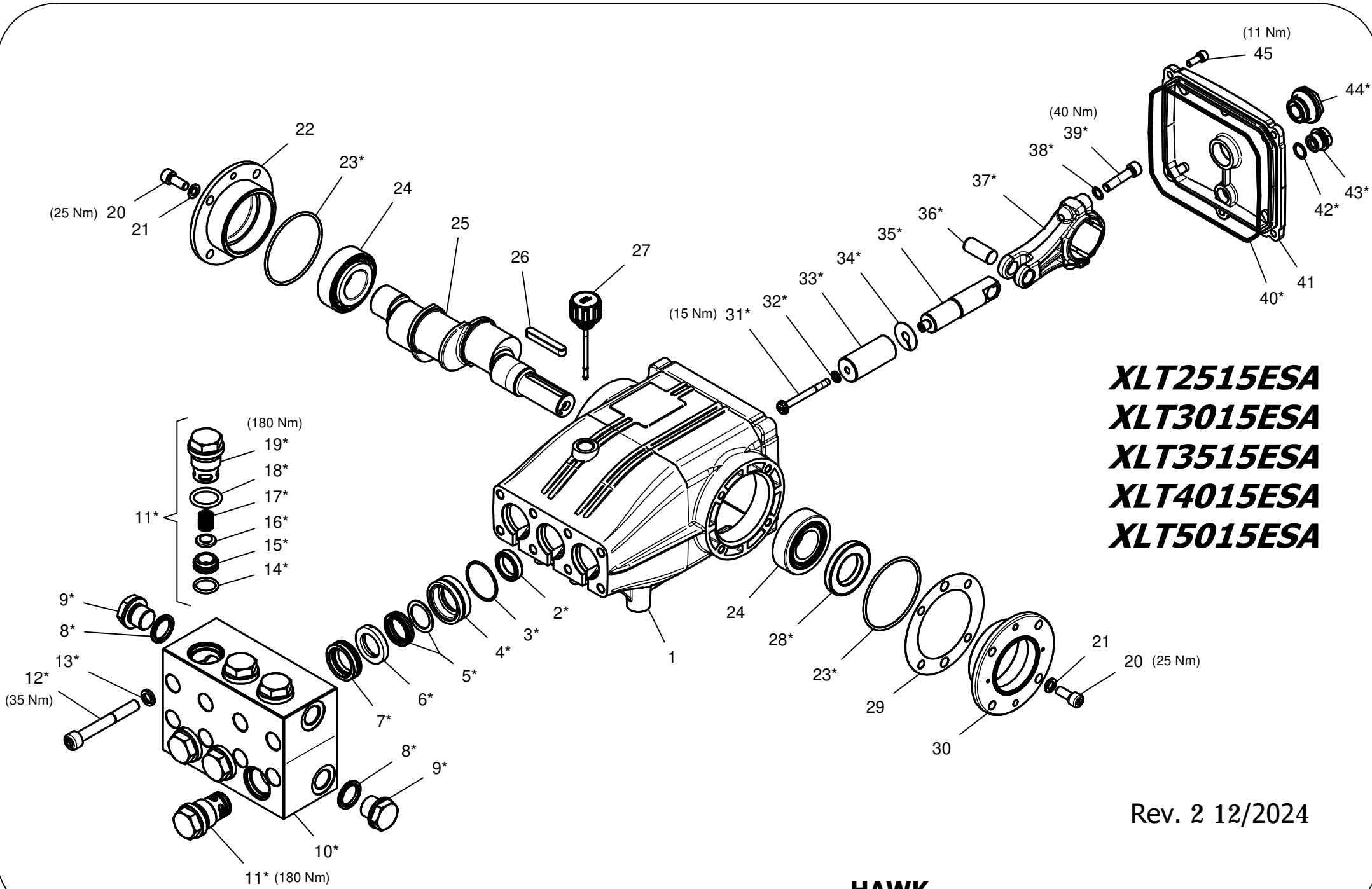

***XLT2515ESA***  
***XLT3015ESA***  
***XLT3515ESA***  
***XLT4015ESA***  
***XLT5015ESA***

Rev. 2 12/2024

**HAWK**  
**Pompe XLT ESA serie 2020**  
**XLT ESA pumps 2020 series**

## HAWK XLT ESA 2020 SERIES

### ORDINARY MAINTENANCE KIT / KIT MANUTENZIONE ORDINARIA

KIT	Item Pos.	Part Number Codice	Description	Descrizione	Q.TY by Pump Q.TA per Pompa	XLT2515ESA	XLT3015ESA	XLT3515ESA	XLT4015ESA	XLT5015ESA
A	3- 5- 7	1.904-464.0	PLUNGER SEALS DIA. 25 mm	GUARNIZIONI PISTONE Ø25	1					
B	11 (14- 15- 16- 17- 18- 19)	1.905-802.0	COMPLETE VALVE	VALVOLA COMPLETA	1	•	•	•	•	•

### EXTRAORDINARY MAINTENANCE KIT / KIT MANUTENZIONE STRAORDINARIA

KIT	Item Pos.	Part Number Codice	Description	Descrizione	Q.TY by Pump Q.TA per Pompa	XLT2515ESA	XLT3015ESA	XLT3515ESA	XLT4015ESA	XLT5015ESA
C	3- 4- 5- 6- 7	1.905-694.0	COMPLETE SEALS PACKING DIA. 25 mm	PACCO COMPLETO GUARNIZIONI PISTONE Ø25	1					
D	31- 32- 33- 34	1.904-466.0	PLUNGER DIA. 25 mm	PISTONE Ø25	3					
E	2	1.905-545.0	PLUNGER OIL SEALS	ANELLI TENUTA OLIO ASTA	1					
F	23- 28- 40- 42- 43- 44	1.905-613.0	KIT CRANKCASE SEALS	KIT TENUTE CARTER	1	•	•	•	•	•
G	3- 4- 5- 6- 7- 8- 9- 10 11- 12- 13 (14- 15- 16- 17- 18- 19)	1.904-801.0	COMPLETE MANIFOLD	TESTATA COMPLETA	1					
H	31- 32- 35- 36- 37- 38 39	1.905-715.0	CONNECTING ROD PLUNGER ROD ASSY	PREMONTATO ASTA-BIELLA-PISTONE	3					

“Q.TY by Pump” => Necessary quantity to repair one pump  
 “Q.TA’ per Pompa” => Quantità necessaria per riparare una pompa

## TOOL KIT

<i>Part Number Codice</i>	<i>Description</i>	<i>Descrizione</i>	<i>Q.TY by Pump Q.TA per Pompa</i>	<i>XLT2515ESA</i>	<i>XLT3015ESA</i>	<i>XLT3515ESA</i>	<i>XLT4015ESA</i>	<i>XLT5015ESA</i>
1.099-665.0	TOOL-KIT	TOOL-KIT	1					
1.905-659.0	OIL SEAL EXTRACTOR TOOL-KIT	TOOL-KIT ESTR. PARAOLIO	1	•	•	•	•	•

### **IMPORTANT**

### **IMPORTANTE**

\* **Part available ONLY in kit**  
**Disponibile SOLO in kit**

(...) **Parts pre-assembled**  
**Parti pre-assemblate**

## PARTS LIST LISTA PARTI

Item Pos	Part Number Codice	Description	Descrizione	KIT	Q.TY Q.TA	XLT2515ESA	XLT3015ESA	XLT3515ESA	XLT4015ESA	XLT5015ESA
1	9.853-797.0	RED CRANKCASE	CARTER ROSSO		1					
2*		PLUNGER OIL SEAL FKM	ANELLO RADIALE FKM	E	3					
3*		"O" RING Ø1.78X37.82 EPDM	"O" RING Ø1.78X37.82 EPDM	A-C-G	3					
4*		STAINLESS STEEL PRESSURE RING 25 MM	PRESSORE "U" Ø25 INOX	C-G	3					
5*		LOW PRESSURE "U" SEAL, DIA.25 MM	ANELLO TENUTA "U" Ø25	A-C-G	3					
6*		STAINLESS INTERMED. RING 25 MM	DIFFUSORE INTER. Ø25 INOX	C-G	3					
7*		HIGH PRESSURE "U" SEAL, DIA.25 MM	ANELLO TENUTA "U" Ø25	A-C-G	3					
8*		STAINLESS STEEL BONDED SEAL G 1/2	BONDED SEAL G 1/2 INOX	G	1					
9*		STAINLESS STEEL PLUG G 1/2	TAPPO G 1/2 INOX	G	1					
10*		STAINLESS STEEL MANIFOLD HOUSING	TESTATA INOX	G	1					
11*		VALVE ASSEMBLY	VALVOLA PREMONTATA	B-G	6					
12*		STAINLESS STEEL MANIFOLD STUD BOLT M10X80	VITE TESTATA M10X80 INOX A2-70	G	8					
13*		STAINLESS STEEL LOCK WASHER Ø10,2	ROSETTA ELASTICA Ø10.2 INOX	G	8					
14*		"O" RING Ø2.62X18.72 EPDM	"O" RING Ø2.62X18.72 EPDM	B-G	6					
15*		STAINLESS STEEL VALVE SEAT	SEDE VALVOLA INOX	B-G	6					
16*		STAINLESS STEEL VALVE PLATE	PIATTELLO VALVOLA INOX	B-G	6					
17*		STAINLESS STEEL VALVE SPRING	MOLLA VALVOLA INOX	B-G	6					
18*		"O" RING Ø3.53X23.39 EPDM	"O" RING Ø3.53X23.39 EPDM	B-G	6					
19*		STAINLESS STEEL VALVE PLUG	TAPPO VALVOLA INOX	B-G	6					
20	9.851-476.0	STAINLESS STEEL SCREW M8X20	VITE TCEI M8X20 INOX		8					
21	9.851-133.0	STAINLESS STEEL WASHER Ø8,5	ROSETTA Ø8.5 INOX		8					
22	9.853-799.0	RED CLOSED BEARING HOUSING	FLANGIA CHIUSA CHIUSA		1					
23*		"O" RING Ø2.62X71.12 NBR	"O" RING Ø2.62X71.12 NBR	F	2					
24	9.850-347.0	ROLLER BEARING 33206	CUSCINETTO A RULLI 33206		2					
25	9.850-222.0	SINGLE - ENDED SHAFT	ALBERO SEMPLICE P.D.F.		1					
	9.850-194.0	" " "	" " "							
	9.850-192.0	" " "	" " "							
	9.850-193.0	" " "	" " "							
	9.853-816.0	" " "	" " "							
26	9.850-447.0	CRANKSHAFT KEY	CHIAVETTA		1					
27	9.851-287.0	OIL DIP STICK	TAPPO LIVELLO OLIO		1					
28*		CRANKSHAFT SEAL NBR	ANELLO RADIALE NBR	F	1					
29	9.850-546.0	SHIM	DISTANZIALE		1					
30	9.853-798.0	RED BEARING HOUSING	FLANGIA ROSSA		1					
31*		PLUNGER BOLT	VITE PISTONE	D-H	3					
32*		STAINLESS STEEL PLUNGER BONDED SEAL	BONDED SEAL PISTONE - INOX	D-H	3					
33*		PLUNGER 25 MM	PISTONE 25 MM	D	3					
34*		STAINLESS STEEL SPACER	ROSETTA PISTONE INOX	D	3					

Item Pos	Part Number Codice	Description	Descrizione	KIT	Q.TY Q.TA	XL T2515ESA	XL T3015ESA	XL T3515ESA	XL T4015ESA	XL T5015ESA
35*		PLUNGER ROD	ASTA PISTONE	H	3					
36*		CONNECTING ROD	BIELLA	H	3					
37*		CONNECTING ROD PIN	SPINOTTO	H	3					
38*		SPRING WASHER Ø8	ROSETTA ELASTICA Ø8	H	6					
39*		CONNECTING ROD SCREW M8X35	VITE M8X35	H	6					
40*		"O" RING Ø 2.62X152.07 NBR	"O" RING Ø 2.62X152.07 NBR	F	1	•	•	•	•	•
41	9.853-800.0	RED CRANKCASE COVER	COPERCHIO POSTERIORE ROSSO		1					
42*		"O" RING Ø1.78X14 NBR	"O" RING Ø1.78X14	F	1					
43*		BRASS PLUG G3/8	TAPPO OTTONE G3/8	F	1					
44*		SIGHT GLASS, G3/4	SPIA LIVELLO OLIO G3/4	F	1					
45	9.851-475.0	COVER SCREW STAINLESS STEEL	VITE M6X16 INOX		5					