

NLT HY 2021

Albero cavo/scanalato SAEJ744 –
Hollow shaft SAEJ744

Caratteristiche Tecniche

Technical Characteristics

Pump Pompa	Pressure Pressione		Volume Portata				RPM giri/min		Power Potenza			
			l/min		GPM				HP		kW	
	bar	PSI	50 Hz	60 Hz	50 Hz	60 Hz	50 Hz	60 Hz	50 Hz	60 Hz	50 Hz	60 Hz
NLT2020HY	200	2900	30	36	7.9	9.5	1450	1740	15.5	18.6	11.4	13.7

Dimensioni d'ingombro

Overall dimensions

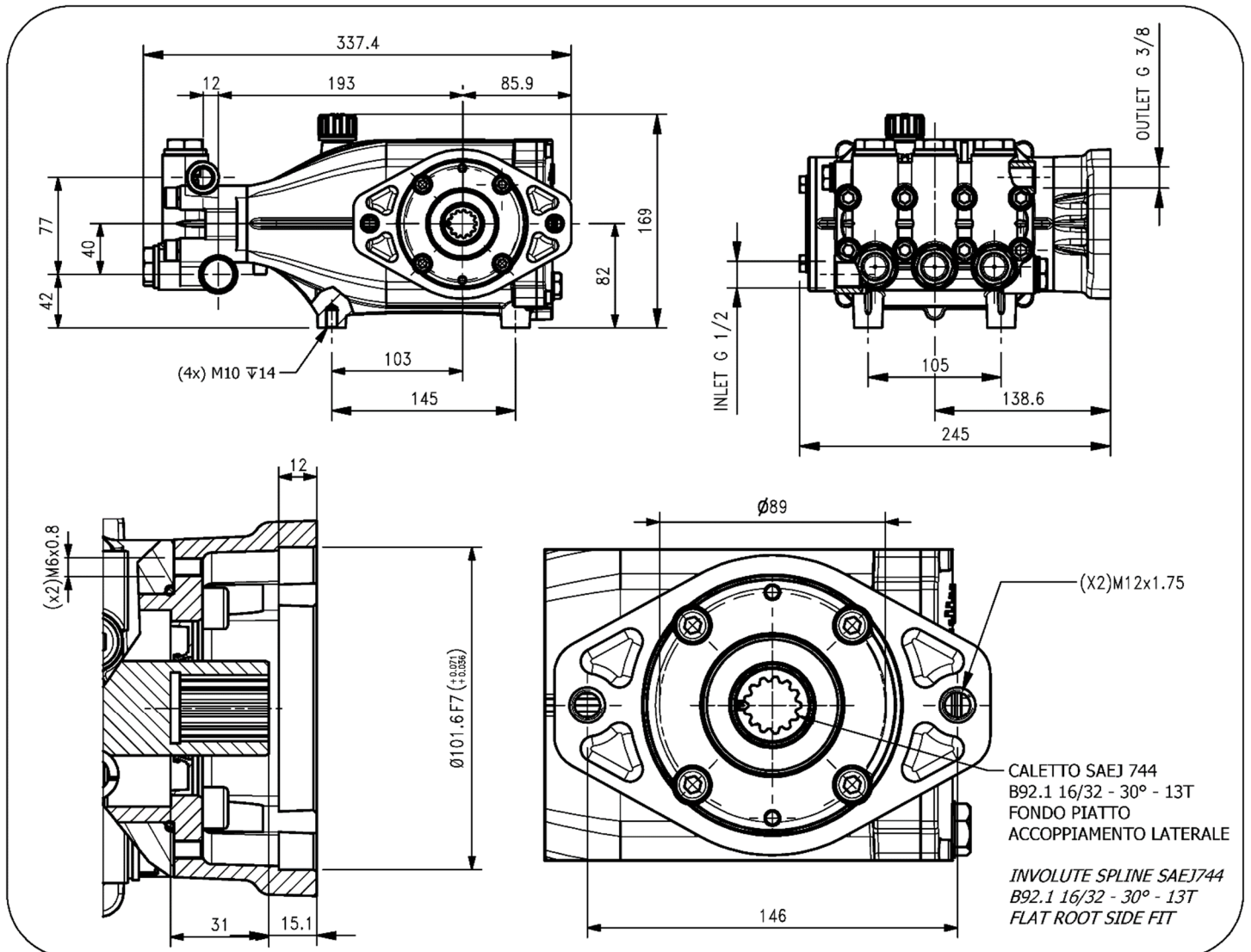

Lubrificazione: Olio SAE 10W40
Capacità: 1.2 Litri
Peso pompa: 18.6 kg

Lubrication: SAE 10W40 Oil
Capacity: 1.2 Litres
Weight: 18.6 kg

LEUCO S.p.A.

Rev. 2 07 - 2022

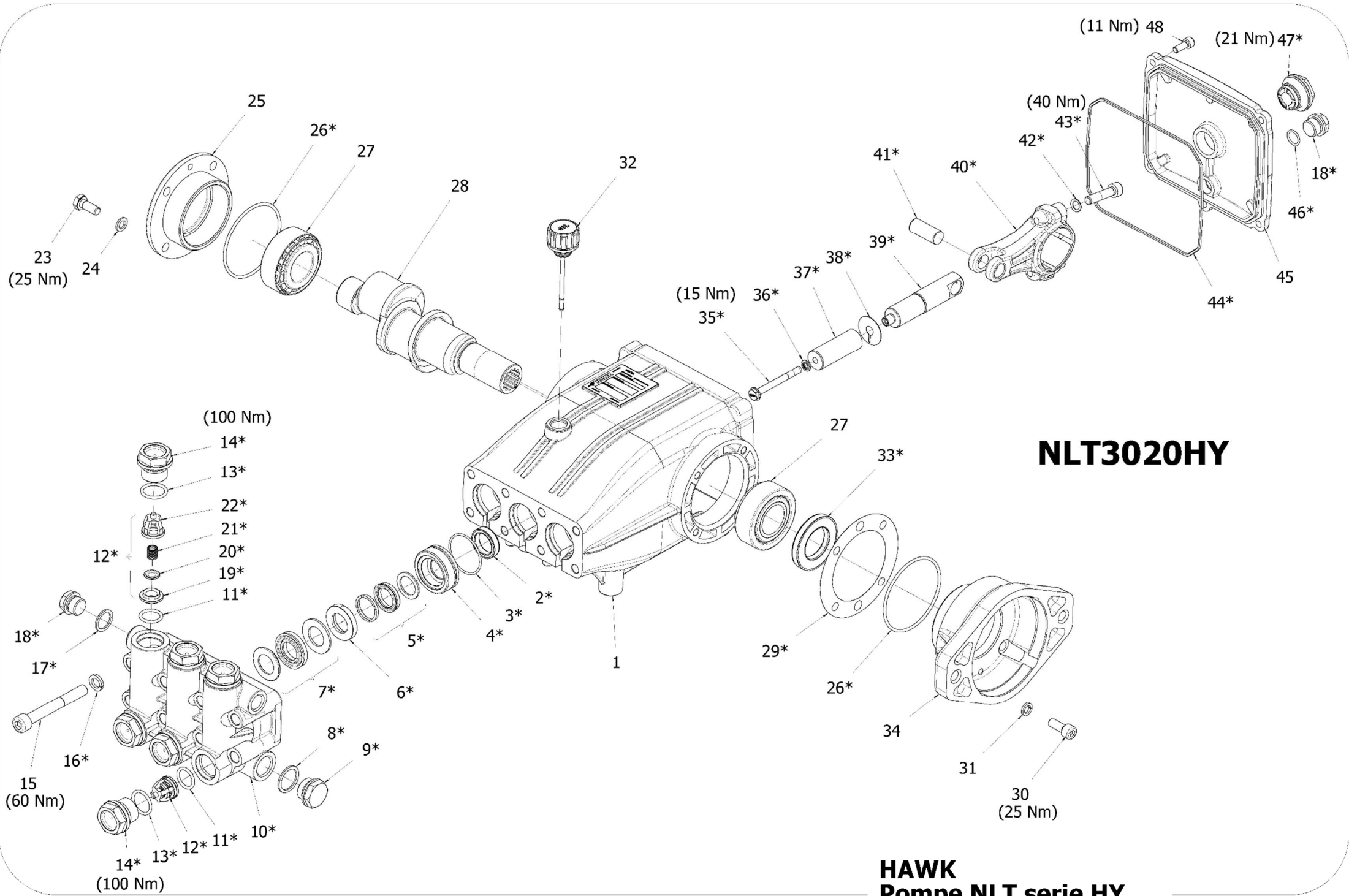

NLT3020HY

HAWK
Pompe NLT serie HY
NLT pumps HY series

NLT HY2021 SERIES

ORDINARY MAINTENANCE KIT / KIT MANUTENZIONE ORDINARIA

KIT	Item - Pos	Part Number - Codice	Description	Descrizione	Q.TY per pump - Q.TÀ per pompa	NLT3020HY
A	3- 5- 7	1.099-759.0	PLUNGER SEALS DIA. 20 mm	GUARNIZIONI PISTONE Ø20	1	
B	11- 12 (19-20- 21 22) - 13	1.905-669.0	COMPLETE VALVE	VALVOLA COMPLETA	1	•

EXTRAORDINARY MAINTENANCE KIT / KIT MANUTENZIONE STRAORDINARIA

KIT	Item - Pos	Part Number - Codice	Description	Descrizione	Q.TY per pump - Q.TÀ per pompa	NLT3020HY
C	3- 4- 5- 6 7	1.905-670.0	COMPLETE SEALS PACKING DIA. 20 mm	PACCO COMPLETO GUARNIZIONI PISTONE Ø20	1	
D	35- 36- 37 38	1.099-763.0	PLUNGER DIA. 20 mm	PISTONE Ø20	3	
E	2	1.099-766.0	PLUNGER OIL SEALS	ANELLI TENUTA OLIO ASTA	1	•
F	18- 26- 33 44- 46- 47	1.905-613.0	KIT CRANKCASE SEALS	KIT TENUTE CARTER	1	•
G	3- 4- 5- 6 7- 8- 9- 10 11- 12- 13 14-15- 16 17- 18	1.099-767.0	COMPLETE MANIFOLD DIA. 20 mm	TESTATA COMPLETA Ø20	1	
H	39- 40- 41 42- 43	1.904-182.0	CONNECTING ROD PLUNGER ROD ASSY	PREMONTATO ASTA-BIELLA PISTONE	3	•
I	13- 14	1.904-251.0	VALVE PLUG ASSY	PREMONTATO TAPPO VAM	6	•

“Q.TY by Pump” => Necessary quantity to repair one pump
 “Q.TA’ per Pompa” => Quantità necessaria per riparare una pompa

OPTIONAL

Part Number - Codice	Description	Descrizione
1.099-665.0	TOOL-KIT	TOOL-KIT
1.905-659.0	SEAL EXTRACTOR TOOL-KIT	TOOL-KIT ESTR. PARAOLIO

IMPORTANT
IMPORTANTE

* **Part available ONLY in kit**
Disponibile SOLO in kit

(...) **Parts pre-assembled**
Parti pre-assemblate

PARTS LIST
LISTA PARTI

Item - Pos	Part Number - Codice	Description	Descrizione	KIT	Q.TY per pump - Q.TÀ per pompa	NLT3020HY
1	9.850-377.0	CRANKCASE	CARTER		1	
2*		PLUNGER OIL SEAL	ANELLO RADIALE	E	3	•
3*		"O" RING Ø1.78X37.82	"O" RING Ø1.78X37.82	A-C-G	3	
4*		PRESSURE RING 20MM	PRESSORE "U" Ø20	C-G	3	•
5*		LOW PRESSURE "U" SEAL, DIA.20MM	ANELLO TENUTA "U" Ø20	A-C-G	3	•
6*		INTERMED. RING 20MM	DIFFUSORE INTER. Ø20	C-G	3	•
7*		HIGH PRESSURE "U" SEAL, DIA.20MM	ANELLO TENUTA "U" Ø20	A-C-G	3	•
8*		COPPER WASHER G1/2	GUARNIZIONE RAME	G	1	•
9*		PLUG G1/2	TAPPO G1/2	G	1	•
10*		MANIFOLD HOUSING DIA.20	TESTATA Ø20	G	1	•
11*		"O" RING Ø2.62X17.13	"O" RING Ø2.62X17.13	B-G	6	
12*		VALVE ASSEMBLY	VALVOLA PREMONTATA	B-G	6	
13*		"O" RING Ø2.62X20.24	"O" RING Ø2.62X20.24	B-G-I	6	
14*		VALVE PLUG	TAPPO VALVOLA	G-I	6	
15*		MANIFOLD SCREW M10X80 GEOMET	VITE M10X80 GEOMET	G	8	
16*		WASHER Ø10,2	ROSETTA Ø10,2	G	8	
17*		COPPER WASHER G3/8	GUARNIZIONE RAME	G	1	•
18*		PLUG G3/8	TAPPO G3/8	G-F	2	
19*		VALVE SEAT	SEDE VALVOLA	B-G	6	
20*		VALVE PLATE	PIATTELLO VALVOLA	B-G	6	
21*		VALVE SPRING	MOLLA VALVOLA	B-G	6	
22*		VALVE CAGE	GABBIA VALVOLA	B-G	6	
23	9.851-503.0	HEXAGONAL SCREW M8X20	VITE M8X20		4	
24	9.851-114.0	WASHER	ROSETTA Ø8,5		4	
25	9.850-624.0	CLOSED BEARING HOUSING	FLANGIA CHIUSA		→	1
26*		"O" RING Ø1.78X71.12	"O" RING Ø1.78X71.12	F	2	•
27	9.853-348.0	ROLLER BEARING	CUSCINETTO A RULLI		2	•
28	9.853-792.0	HOLLOW SHAFT	ALBERO CAVO		1	•
29	9.850-546.0	SHIM	DISTANZIALE		1	•
30	9.851-476.0	SAEJ 744B FLANGE SCREW	VITE FLANGIA SAEJ 744B		4	
31	9.851-157.0	WASHER	RONDELLA		4	
32	9.851-287.0	OIL DIP STICK	TAPPO LIVELLO OLIO		1	•
33*		CRANKSHAFT SEAL	ANELLO RADIALE	F	→	1
34	9.853-795.0	SAE J744B FLANGE	SAE J744B FLANGIA		□	1

Item - Pos	Part Number - Codice	Description	Descrizione	KIT	Q.TY per pump - Q.TÀ per pompa	NLT3020HY
35*		PLUNGER SCREW	VITE PISTONE	D-H	3	•
36*		BONDED SEAL	BONDED SEAL	D-H	3	•
37*		PLUNGER 20MM	PISTONE Ø20	D	3	•
38*		COPPER SPACER	ROSETTA RAME	D	3	
39*		PLUNGER ROD	ASTA PISTONE	H	3	
40*		CONNECTING ROD	BIELLA	H	3	
41*		CONNECTING ROD PIN	SPINOTTO	H	3	
42*		SPRING WASHER Ø6	ROSETTA ELASTICA Ø6	H	6	
43*		CONNECTING ROD SCREW M8X35	VITE M8X35	H	6	•
44*		"O" RING Ø 2.62X152.07	"O" RING Ø 2.62X152.07	F	1	
45	9.850-389.0	CRANKCASE COVER	COPERCHIO POSTERIORE		1	
46*		"O" RING Ø1.78X14	"O" RING Ø1.78X14	F	1	
47*		SIGHT GLASS, G3/4	SPIA LIVELLO OLIO G3/4	F	1	
48	9.851-474.0	SCREW M6X16	VITE M6X16		5	