

INSTRUCTION MANUAL

Version 00021
ORIGINAL
INSTRUCTIONS

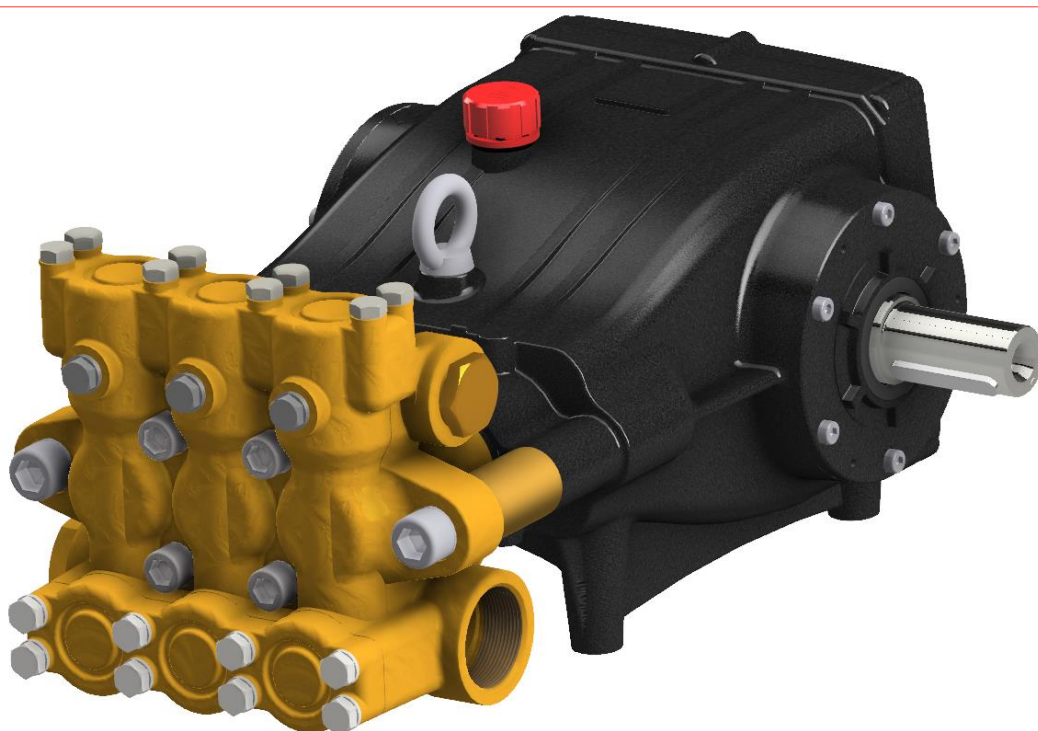

POSITIVE DISPLACEMENT HIGH PRESSURE PISTON PUMPS TXT SERIES

LEUCO S.p.A.

Via Colletta, 20
42124 Reggio Emilia (RE) - ITALY
Tel. 0522/923011 Fax 0522/923030

*This manual and associated information can be downloaded from the website:
www.hawkspumps.com*

This manual is an integral part of the product and should always be made available to any persons using it

CONTENTS

1	GENERAL INFORMATION	4
1.1	Structure of the Manual 4	
1.1.1	Scope and content.....	4
1.1.2	Recipients/definitions.....	4
1.1.3	Storage.....	5
1.1.4	Symbols used in the manual.....	5
1.2	Manufacturer.....	5
1.3	Service Centres	5
1.4	CE Mark and Certification - Declaration of Incorporation 6	
1.5	Guarantee.....	6
2	GENERAL DESCRIPTION.....	7
2.1	Main parts.....	8
2.1.1	Technical characteristics.....	9
2.2	Ambient conditions	9
2.3	Vibrations.....	9
2.4	Noise	10
2.5	High temperatures.....	10
2.6	Stability.....	10
2.7	Pressurised liquids.....	10
3	SAFETY.....	10
3.1	General safety instructions.....	10
3.2	Residual risks	11
3.3	Personal protective equipment 12	
3.4	Working safely 12	
3.4.1	Safety when using the pump 12	
3.4.2	Safety when using high pressure circuits 12	
3.5	Safety during lifting and handling 13	
3.5.1	Packing, unpacking and transport 13	
3.6	Safety during maintenance 14	
3.7	Products used 14	
3.8	Product labels 14	
3.9	First Aid 15	
3.9.1	First Aider duties 15	
3.9.2	Emergency call.....	15
3.9.3	Injuries	15
3.9.4	Bleeding	16
4	INTENDED USE	16
4.1	Intended use.....	16
4.2	Improper Uses 16	
5	INSTALLATION AND ASSEMBLY 17	
5.1	Responsibilities of the Customer/User 18	
5.1.1	Placing.....	18
5.1.2	Rotation direction.....	19
5.1.3	Plumbing connections	19
5.1.4	Suction line	19
5.1.5	Filter.....	19
5.1.6	Discharge line	20
5.2	Pre-commissioning instructions 20	
5.3	Long periods of inactivity 20	
5.4	Operation.....	21

6	MAINTENANCE.....	26
6.1	General maintenance	26
6.2	Removal of mechanical parts 27	
6.3	Assembly of mechanical parts 28	
6.4	Inspecting the bearings	28
6.5	Changing the bearing.....	29
6.6	Maintenance of the hydraulic part 29	
6.6.1	Replacement of suction/delivery valves 29	
6.6.2	Replacement of the seals	30
6.6.3	Replacing the plungers	33
7	TROUBLESHOOTING.....	33
7.1	Problems and potential remedies 33	
8	DISMANTLING AND DISPOSAL	34
9	SPARE PARTS.....	34
10	ATTACHMENTS 34	

1 GENERAL INFORMATION

1.1 Structure of the Manual

This manual is an integral part of the official documents provided with the pump. It is written by the Manufacturer and provides the operating instructions and criteria to be followed for the installation, use and maintenance of the pump.

Before choosing and/or using any LEUCO product, it is important that the customer controls all aspects related to its specific application with due care and studies the information provided in the technical sales literature published by LEUCO. As LEUCO products may be used in different operating conditions and/or applications, the customer is responsible for carrying out any tests and analysis that will help him choose the best product for his needs. He is also responsible for complying with all operating specifications and safety requisites.

LEUCO's products and publications are subject to change at any time without notice.

The customer must ensure the installation is carried out in full compliance with the instructions provided in this manual, as well as with current national legislation and standards.

The Manufacturer is not liable for any damages caused by incorrect use, negligence, superficial interpretation or total lack of application of the safety related information provided in this manual.

1.1.1 Scope and contents

These operating instructions provide all the information concerning the installation, use, maintenance, storage and all stages of the life cycle of the high-pressure positive displacement piston pumps to be observed by any persons involved in its assembly/end user in order to prevent possible risks.

Operators and qualified technicians must read the instructions in this publication with due care before starting any operation on the equipment.

Contact LEUCO S.p.A for the necessary explanations if you have any doubts regarding the correct meaning of the instructions.

1.1.2 Recipients / Definitions

These instructions are intended for skilled personnel who have been given appropriate training for carrying out installation and routine maintenance.

Customer

The person, public agency or private company who bought the pump and intends to use for its intended purposes. This may also be the person responsible for its assembly provided he has the necessary requisites.

User/Operator

An authorised person with the requisites, skills and information needed to use the pump, machine or system where the pump is fitted, and to carry out routine maintenance.

Ordinary/general maintenance

The actions required to maintain the machine in good working order, to guarantee a longer working life and to safeguard safety requisites at all times. The Manufacturer has provided a description of the maintenance schedule and methods in this manual. Maintenance may be carried out by qualified personnel, including the operator, as described above.

Supplementary maintenance

The actions required to restore the working order and efficiency of the machine. Such actions are required in case of sudden anomaly and may only be carried out by a specialised technician.

Installer/Assembler

An authorised technician with the specific requisites and skills needed to carry out the actions needed to install the pump and/or similar machines and to carry out routine maintenance in complete safety, independently and without incurring risks.

Training

The period when the operators are given the necessary instructions to carry out any actions in a correct and risk free manner.



Person at risk





Any person finding themselves totally or partly in a danger zone.

1.1.3 Storage

This instructions manual should be kept in the direct vicinity of the machine, in a specific container, protected from contact with liquids and any other substance that could render it illegible.

1.1.4 Symbols used in the manual

SYMBOL	MEANING	COMMENT
	DANGER	Indicates a potentially serious risk for the user/assembler.
	CRUSHING HAZARD FOR UPPER AND LOWER LIMBS	Indicates the danger of crushing the upper limbs when positioning or handling the pump.
	MOVING MECHANICAL PARTS HAZARD	Indicates a hazard due to the presence of moving parts (such as drive shafts or reduction units).

SYMBOL	MEANING	COMMENT
	WARNING	A warning or note regarding key features or useful information. Pay maximum attention to the text boxes indicated by these symbols.
	SAFETY INFORMATION	
	REFERENCE	Refer to the instructions manual before attempting any action.
	ADJUSTMENTS/MAINTENANCE	Specific mechanical adjustment and/or electrical calibration (when applicable) may be necessary for special operating modes and/or in the event of anomalies.

1.2 Manufacturer

	LEUCO S.p.A. Via Colletta, 20 - 42124 Reggio Emilia (RE) - ITALY
---	---

1.3 Service Centres

Contact LEUCO S.p.A. or specialised personnel authorised by the Manufacturer for further information relating to operation or maintenance.

Make a note of the information you will find on the pump's specifications plate and the type of fault found whenever requesting technical assistance.

1.4 CE Mark and Certification - Declaration of Incorporation

The Hawk high pressure piston pumps described in this manual are manufactured in compliance with Directive 2006/42/CE and European Community Directives that are pertinent and applicable at the time they are sold. As they are "partly completed machinery" according to Article 2, letter g) of the above Directive, a Declaration of Incorporation is issued in place of a certification. As its contents make clear, the final Installer is responsible for issuing the declaration of conformity and relative CE mark (which may be the same person as the Customer).

These assembly instructions were drafted in accordance with Annex VI of the above Directive.

This instructions manual complies with Annex I section 1.7.4 of the above Directive as well as UNI 10893 standard and ISO/IEC 37 guidelines.



The list of Directives and the standards applied can be found in the Declaration of Incorporation in the attachments (Attachment I) of this Manual.

1.5 Guarantee

LEUCO S.p.A. guarantees HAWK products from defects in their construction and materials for a period of (1) year from the time they left the factory.

This guarantee is limited to the repair and replacement of parts or products that LEUCO S.p.A. deems were defective at the time of delivery. All the products covered by this limited guarantee must be returned freight paid for inspection, repair or replacement by the manufacturer.

This limited warranty is the only form of valid guarantee and replaces any other form of explicit or implicit warranty, including any guarantee of fitness for sale or any particular purpose. The manufacturer refuses any such liability with this statement.

Faulty products will only be repaired or replaced according to these terms. LEUCO S.p.A. is not liable for any further loss, damage or expense, including accidental or indirect damages caused directly or indirectly from the sale or use of these products.

Any unauthorised use of spare parts that were not manufactured by LEUCO S.p.A. automatically invalidates this guarantee, which is subject to compliance with the instructions for installation and operation provided. There are no additional guarantees other than the guarantee described above.

All pumps supplied by LEUCO are carefully controlled during their production and undergo cycles of testing before shipment. For optimum pump performance, to prevent incidents and avoid invalidating the guarantee, it is essential to comply with the procedures described in this manual regarding the correct assembly and initial start-up of the pump.



LEUCO S.p.A. is not liable for any errors made when drafting this manual.



The Manufacturer is not liable in case of any unauthorised modification to the product or to any part of it and any such action will invalidate the guarantee.

2 GENERAL DESCRIPTION

TXT pumps are designed to operate with clean water, at a maximum temperature of 65°C.

The duration of the seals will depend on the temperature of the water: the warmer the water, the more likely that deleterious cavitation phenomena - known to reduce the useful life of seal components - will occur.

The pump performance (flow rate, pressure, rpm) indicated in this manual and in the catalogue refers to the pump's maximum specifications and should not be exceeded for any reason.

The TXT pumps have two suction inlets and two delivery outlets (refer to the section 2.1.1 "Technical characteristics" table for the dimensions of your model). The system may be connected to one or both delivery outlets and suction inlets without affecting the pump's operation.

Unused ports must, however, be hermetically sealed.

The main parameters that determine your choice of Hawk pump are volume, pressure, rotation speed and power consumption.

- The volume is given in litres per minute and is directly proportional to the rotation speed.
- The speed of rotation is given as revolutions per minute.
- The pressure is given in bars and is the maximum pressure that the pump can reach.
- The power consumption is shown in kW and is the absorption required to achieve the maximum flow rate and pressure indicated.

When coupled with an electric motor, the power of the motor should be greater than that shown in the catalogue. When coupled with a combustion engine, the power of the engine should be at least 30% more than that shown in the catalogue.

The power consumed by the pump in KW is the product of:

$$\text{Power} = \text{Volume Rate (l/min)} \times \text{Pressure (bar)} / 520$$



The list of pump models to which this manual refers is attached to the Declaration of Incorporation accompanying the pump (ANNEX I).



Hawk pumps were not designed for pumping potentially hazardous liquids (explosive, toxic and flammable liquids). Contact the Manufacturer in case of doubt.



**Before choosing and/or using any LEUCO product, it is important that the customer controls all aspects related to the specific application with due care and studies the information provided in the technical and sales literature published by LEUCO S.p.A.
LEUCO's products and this document are subject to change at any time without notice.**

2.1 Main parts

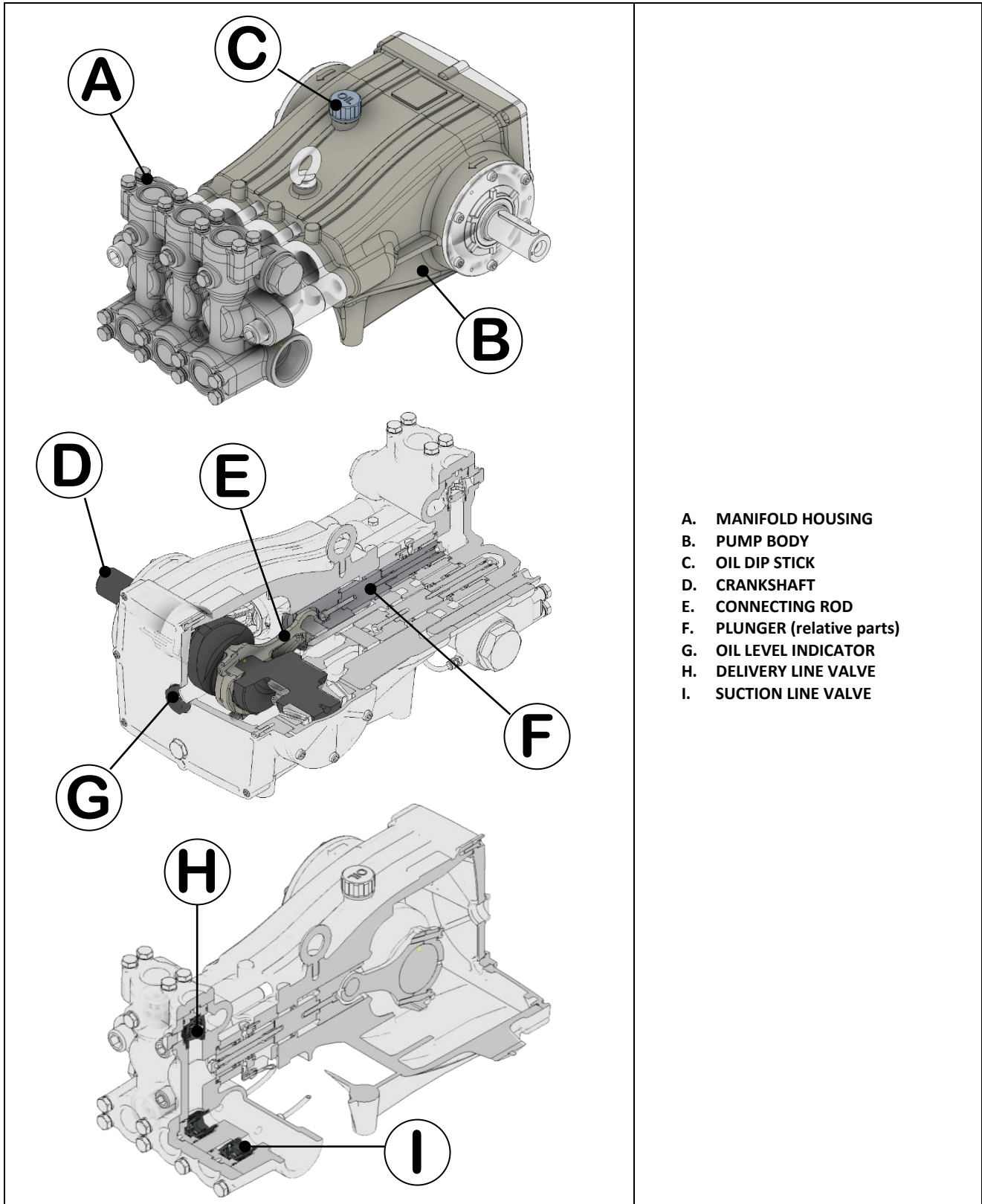

More details on the parts can be found in the exploded views attached to this manual (ATTACHMENT II).

The pumping action is created by a series of plungers, connected to the drive shaft by connecting rods. During motion, the plungers slide on their axis inside the manifold housing where the suction and delivery lines are fitted with valves that allow the liquid to flow in a single direction.

2.1.1 Technical characteristics

The main dimensions and specifications are as follows:

Caratteristiche Tecniche					Technical Characteristics					
Pump Pompa Pumpen Pompa	Pressure Pression Druck Pressione		Volume Debit Wassermenge Capacity		RPM Tours/min u.p.m. giri/min	Required Puissance Leistung Potenza		Inlet port Entrée Eingang Aspirazione	Outlet Sortie Ausgang Mandata	Weight Poids Gewicht Weight
	Bar	PSI	l/min	GPM		kW	HP			
			50 Hz	50 Hz	50 Hz	50 Hz	50 Hz			
TXT1225R	250	3625	120	31.70	1000	57.70	77.38	G 2"	G 1"	74.5
TXT1225L	250	3625	120	31.70	1000	57.70	77.38	G 2"	G 1"	74.5
TXT1520R	200	2900	150	39.63	1000	57.70	77.38	G 2"	G 1"	74.5
TXT1520L	200	2900	150	39.63	1000	57.70	77.38	G 2"	G 1"	74.5
TXT1817R	170	2465	180	47.55	1000	58.80	78.85	G 2"	G 1 1/4"	74.5
TXT1817L	170	2465	180	47.55	1000	58.80	78.85	G 2"	G 1 1/4"	74.5
TXT2214R	140	2175	220	58.12	1000	59.20	79.39	G 2"	G 1 1/4"	74.5
TXT2214L	140	2175	220	58.12	1000	59.20	79.39	G 2"	G 1 1/4"	74.5

Detailed technical specifications for each range or series, with the associated product versions, are provided in ATTACHMENT II at the end of this document.

2.2 Ambient conditions

The local operating conditions are specified on the product's specifications plate (see the facsimile in section 3.8). Some of the operating conditions are listed below.

Parameter	Tolerated values
Room temperature	from -10°C a +50°C
Storage temperature	from 0°C a +50°C
Humidity	from 20% to 80%



**The Hawk pumps described in this manual were NOT designed or built for operating in potentially explosive environments.
Contact the Manufacturer or refer to the product catalogue for details of suitable pumps.**

2.3 Vibrations

Hawk pumps will not produce hazardous vibrations in conditions of normal use and provided the installation and assembly instructions in this document were carried out properly. In addition, there will be no contact with the operator during operation, as the pump is part of the machine/system it is fitted on.

2.4 Noise

The equipment was designed and built to reduce the generation of noise at source as far as its application and method of use allows this.

The noise measured is below the minimum level envisaged in current legal standards.

2.5 High temperatures

Mechanical parts are lubricated to prevent them overheating as a result of prolonged friction. The lubricating oil is indicated below in this manual and takes into account the specifications of the pumps that make up the assembly. There is no probable risk provided normal maintenance procedures are followed.

Operators should use appropriate personal protective equipment provided, including work wear and gloves.

2.6 Stability

Instructions are supplied with LEUCO pumps to ensure a stable and safe assembly on the machine/system that incorporates them. The assembler/operator must follow these instructions carefully.

The pumps were designed and built so that they do not present any hazard in terms of stability in conditions of normal use.



More information is provided in section 5 "Installation".

2.7 Pressurised liquids



The pumps described in this manual are built using materials that are capable of tolerating the envisaged operating pressures. They are complete with all the necessary parts (plugs, valves, plungers, etc..) for the correct operation and circulation of the liquids (water and lubricating oil). The lubricating transmission products contained in the pump body are used to safeguard correct pump operation by keeping the mechanical parts lubricated.

3 SAFETY





3.1 General safety instructions







Hawk pumps were designed to be safe to operate for the intended purposes, provided they are run (incorporated), used and maintained according to the instructions in these operating and maintenance instructions.



Before attempting to install or use the pumps, the machine operators and any other personnel involved must read and understand the instructions provided in the manual and the project data for installation.

	Do not tamper with equipment. The manufacturer is not liable in case of incorrect pump operation or for any damage resulting from use of the product if tampering is suspected.
	Before using the equipment, make sure that any safety hazard has been eliminated.

Operators must follow the safety instructions below:



	Do not attempt to remove or alter any part of the pump, unless instructed in this manual and in the manner described.
	Only qualified technical personnel authorised by the Manufacturer may undertake internal inspections, modifications or repairs.
	Do not allow unauthorised personnel to tamper with the equipment.
	Do not wear rings, wrist watches, jewellery, loose clothing or items like neck ties, scarves, torn clothing, unbuttoned jackets or shirts with open zips, as these could get caught in moving parts.

	Wear appropriate personal protective equipment as specified in the manual for the work to be carried out.
	Make sure all the steps described in the section on maintenance are carried out regularly.
	The equipment must be taken out of service immediately in case of malfunction or damage that could affect its operation and safety.
	Notify the personnel in charge of maintenance in case of any operating anomaly.
	Make sure that all protective guards and other devices are in place and that all safety devices are present and working properly (pump crankcase and the safety devices on the machine/system where the pump is fitted).
	Check that the direction of rotation of the motor is the same as that of the pump when it is started up for the first time or after any maintenance.
	Make sure all the steps described in the section on maintenance are carried out regularly.

 	Check if there are any other safety instructions that must be followed in the Operating and Maintenance Manual for the machine where the pump is fitted.
---	---

3.2 Residual risks

The pumps were designed and built in order to eliminate any risks associated with their operation. The residual risks are described below:

a) Crushing:	
Handling and positioning the pump may bring the risk of crushing the upper limbs or hands or feet. Pay particular attention when undertaking these actions. It is compulsory to wear the personal protective equipment provided (work gloves and boots) and to comply with all the procedures designed to safeguard the correct completion of the operating cycle.	
b) Heat-related hazards:	
The pump can reach high temperatures during operation depending on the temperature of the pumped liquid. As a result, the person in charge of the installation must bear this in mind and provide appropriate safety devices and warning signs for personnel.	

 	Pay attention when operating pumps from the XLTI..HT, NMT..HT, XXT..HT range as they may reach temperatures up to 85°C.
---	--

3.3 Personal protective equipment



Failure to use the personal protective equipment specified in this section will expose the machine operators to danger.
Employers are required to provide personal protective equipment to the operators using the machine referred to in this manual.

The operators using the equipment must wear the following personal protective equipment, in line with the work being carried out:

- **Personal protective equipment against the risk of cuts, bruises and high temperatures (max 85 °C)**
- **Work boots**
- **Safety goggles or glasses (if necessary)**



The Employer may decide to use additional safety equipment after assessing any risks and considering any changes made to the production processes.

3.4 Working safely

To reduce the consequences of the hazards described in the section above, operators must comply with the following instructions:

- **Wear** the personal protective equipment referred to in section 3.3;
- **Monitor areas where any hazard is present**, do not start a test cycle if there are any persons located within the hazardous area or in the immediate vicinity who are not involved in the job to be undertaken. Release the controls immediately should any unauthorised persons enter the hazardous area when work is underway.

3.4.1 Safety when using the pump

The area and environment that the high pressure system operates in must be clearly signposted and prohibited to unauthorised personnel. The area should also be restricted and defined. The staff responsible for carrying out the work must first undergo workplace conduct training as well as training on the risks arising from high pressure system damages or defects.

Prior to starting up the system, the operator or operators are required to check that:

- the system has the correct power supply;
- the electrical parts are correctly and adequately protected and work efficiently;
- the high pressure hoses and hose fittings do not exhibit signs of abrasion or excessive wear.

Any defect, damage or reasonable doubt that might arise before or during the operation must be reported and verified by qualified staff. Should this happen, the system must be stopped immediately and the pressure brought down to zero.

3.4.2 Safety when using high pressure circuits

Here below are some basic indications regarding the high pressure circuit where the pump can be installed.

High pressure circuits should always be fitted with a safety or pressure relief valve.

Components of the high pressure circuits, particularly those that mainly operate outdoors, must be resistant to weather conditions such as rain, frost or heat. All electrical parts should have adequate protection against direct or indirect sprays of water and be suitable for use in wet environments.

High pressure hoses must be sized in accordance with the maximum operating pressure of the circuit and always within the field of operation specified by the hose manufacturer. These precautions should also be followed for all the components found within high pressure circuits. The ends of the high pressure hoses should be sheathed or, in any event, secured to a structure in order to prevent dangerous whiplash in the event of a blast or a rupture in the connections.

Lastly, appropriately sized cranks must be provided in order to protect the rotating component parts for the motion transmission (flexible couplings and universal joints, belts, pulleys, etc.).



Check if there are any other safety instructions that must be followed in the Operating and Maintenance Manual for the machine where the pump is fitted.

3.4.3 Rules of conduct regarding the use of high pressure lance

Here below are some basic indications regarding the use of the pump with high pressure lance equipment.

Those who operate high pressure nozzles must always put their own safety - as well as the safety of third parties likely to be affected by their actions - before any other assessment or action in respect of the situation. Their work must always be guided by common sense and an awareness of responsibility and precautions. The operator should not be distracted while working, for any reason.

The operator must always have appropriate personal protective equipment that guarantee good grip and stability on the ground in wet conditions.









The area affected by the water jet must be restricted and free from objects which, if hit by the jet, might be damaged or projected elsewhere.

The jet should always be aimed in the direction of the workspace, including during preliminary or trial operations.

Attention must always be paid to the trajectory of debris removed from the jet. If necessary, anything that might be exposed to the jet should be given adequate protection.

 	<p>Check if there are any other safety instructions that must be followed in the Operating and Maintenance Manual for the machine where the pump is fitted.</p>
---	--

3.5 Safety during lifting and handling

 	<p>Before starting work, clear the work area so that the lifting and movement of materials can be safely undertaken.</p>
 	<p>Only authorised, qualified personnel who have received specific training may perform unloading, loading, handling and lifting operations.</p>
 	<p>People who are not involved in the operations must keep at a safe distance during lifting and handling.</p>
 	<p>All equipment used for lifting and transport, including accessories (such as hooks, ropes and chains), must be of a suitable capacity and checked regularly according to legal standards.</p>

3.5.1 Packing, unpacking and transport

The packing used for Hawk pumps was designed specifically to prevent damage caused by impact or vibration during transport or handling.

Each pump is packed so that it is protected from stress and impact, and will not be damaged during transport.

Based on the amount of goods to be shipped and the final place of destination, the packed pumps can be placed on a pallet to facilitate lifting and handling.

When unpacking, check the parts are intact and they are the correct amount. If any parts are damaged or missing, contact your dealer or the Manufacturer for instructions.

Dispose of packing materials correctly according to legal obligations.

Different means of transport may be used to ship Hawk pumps (road, rail, sea or air) depending on their final destination.

Secure the packs to the vehicle properly during transport to prevent movement.

 	<p>Failure to comply with these instructions may lead to situations of extreme danger.</p>
---	---

 	<p>Manual handling of loads must comply with ISO 11228-1, or any applicable national legislation.</p>
---	--

3.6 Safety during Maintenance

Follow the instructions below whenever carrying out any maintenance or repair work:



Depressurise the water system and disconnect the pump from any power source before starting any maintenance or repair work.

- Before starting work, hang a "**MACHINE UNDERGOING MAINTENANCE**" sign in a prominent position on the machine/system where the pump is fitted
- Do not use solvents or flammable chemicals or materials for cleaning that could generate static electricity
- Be careful not to spill any oil or lubricant
- When you have finished the job, replace any safety guards and covers that were removed or opened and secure them properly.



Only qualified technical personnel are authorised to carry out maintenance/repair work.

3.7 Products used

All the products used during normal operation, including oils, lubricants and cleaning products, must be used as instructed in the safety notices provided by the manufacturer.



Use the oil already in the pump for the first 50 hours and then replace with SAE 10/40W oil, as shown on the label.

The TXT pumps are already filled with SAE 10/40W oil, as these pumps are already run-in when they are delivered by the Manufacturer.

Dispose of used oil correctly according to legal obligations.

3.8 Product Labels

The hazard, warning and compulsory signs illustrated in this manual are placed in the vicinity of the equipment. Providing an exact description of the pump, model, serial number and technical data makes it easier for the technical personnel to deliver a fast and efficient service (if needed).

The identification data is on the label attached to the equipment, as shown below.



Do not remove (or change the position) of any type of id plate and/or labels containing information and/or warning notices on the equipment.

FAC – SIMILE
Machine Id Plate



Other signs on the equipment



3.9 First Aid

A brief description follows of some of the standard First Aid procedures that may be useful in case of injury when using the pump or the machine/plant where it is fitted.

They may be useful if a machine operator has to handle an emergency when using the equipment during the various stages of its working life (transport, installation, operation, maintenance, adjustments, etc.) or assist others in the direct vicinity of the equipment.

3.9.1 First aider duties

- Calls for help (emergency call);
- Assesses the condition of the injured person and sustains their vital functions, if necessary;
- Stops the flow of blood;
- Protects wounds and burns;
- Protects the injured person from further injury;
- Does not take any unnecessary or potentially harmful initiative like moving the injured person or giving him a drink, attempting to treat sprains and/or broken bones, etc..

3.9.2 Emergency Call

To be sure of a successful outcome, it is important to make sure the emergency services can reach the place of the event without delay.

So it is very important that the first aider who calls the emergency services, gives the following information:

- The address where the accident (or medical emergency) has taken place;
- How many people are injured (or ill);
- What may have caused the emergency;
- The status of the injured person's vital functions, whether he is conscious or not, and whether he is breathing normally or not.

After confirming the above information, it is advisable to:

- give your own name and a telephone number where you can be reached;
- wait outside for the emergency services to arrive (near the main entrance, for example).

Calling the emergency services is of major importance. Do everything you are instructed to do by the emergency team to ensure a successful outcome.

3.9.3 Injuries

What to do in case of sprains, dislocations or broken bones:

Use a splint or a bandage to immobilise the area where the injury occurred, in the position that causes less pain for the injured person and without attempting any unnecessary and potentially harmful manoeuvres. Apply a cold pack (an ice pack or similar). In case of an open fracture, apply pressure away from the fracture to stop the bleeding and then cover the injury with a sterile dressing.

Bruises, crushing:

If the upper or lower extremities of a limb have been bruised and/or crushed (fingers, hands, feet, etc.), put the affected limb immediately under (cold) running water and then apply an ice pack. Check for open wounds and/or cuts and disinfect the affected area if necessary.

3.9.4 Bleeding

It may be necessary to apply direct pressure to the bleeding area using a sterile dressing, lift the limb and apply pressure upstream to the origin of the bleeding with a tourniquet



Surface wounds:

Expose the wound and clean it with water, disinfect it with saline solution and medicate it, covering it with a sterile dressing. Cover this with a bandage without tightening the bandage excessively to permit normal circulation.

Deep wounds:

Wearing gloves and a facemask to protect yourself from the risk of infection is a priority. Compress the area until the bleeding stops or the ambulance arrives by applying direct pressure or using other pressure points. Call the emergency services (each country has its own number for the emergency services) and inform them that the person has arterial bleeding.

Do not attempt to treat the wound before the bleeding has been controlled.



	Do NOT use cotton wool, alcohol or antibiotic powder to disinfect a wound.
	Always remember to wear latex gloves to prevent contact with body fluids.

4 INTENDED USE

4.1 Intended use

Hawk pumps must not be used for any other purposes than those described in these instructions. Complying with the terms of use, repair and maintenance specified by the Manufacturer in strict accordance are an essential element with regard to the intended use.

The Hawk pumps described in these instructions were designed and built to be incorporated in cleaning machines/equipment (high pressure cleaner). In addition, they must be used in a way that corresponds to their technical characteristics (par. 2.1.1), without undergoing any modifications that have not been agreed upon or that are being used for improper purposes.

	The pump may ONLY be used and fitted by trained and qualified personnel who are familiar with the information in this manual.
	Do not operate the pump until the machine where it is fitted has been declared as compliant with current legal standards (e.g. Directive 2006/42/EC).

4.2 Improper Uses

The equipment must not be used:

- By any recipients other than those referred to in 1.1.2
- For any other uses than those described in section 2 and section 4.1
- In any other operating conditions than those described in section 2.2
- For pumping liquids that are flammable, toxic, corrosive or with an unsuitable density or temperatures higher than those specified in the technical data listed in this document or on the product's specifications label
- For pumping drinking water
- For food uses

- For pharmaceuticals
- In potentially explosive atmospheres (see the specific Hawk product range)



The Manufacturer reserves the right to review the terms of the guarantee if the equipment is used for any other purpose than those mentioned above.

5 INSTALLATION AND ASSEMBLY

Read this chapter with due care before starting to install the machine.



Failure to install the pumping system correctly can result in injury or damage to property: it is important to follow all the points below.

General scheme:

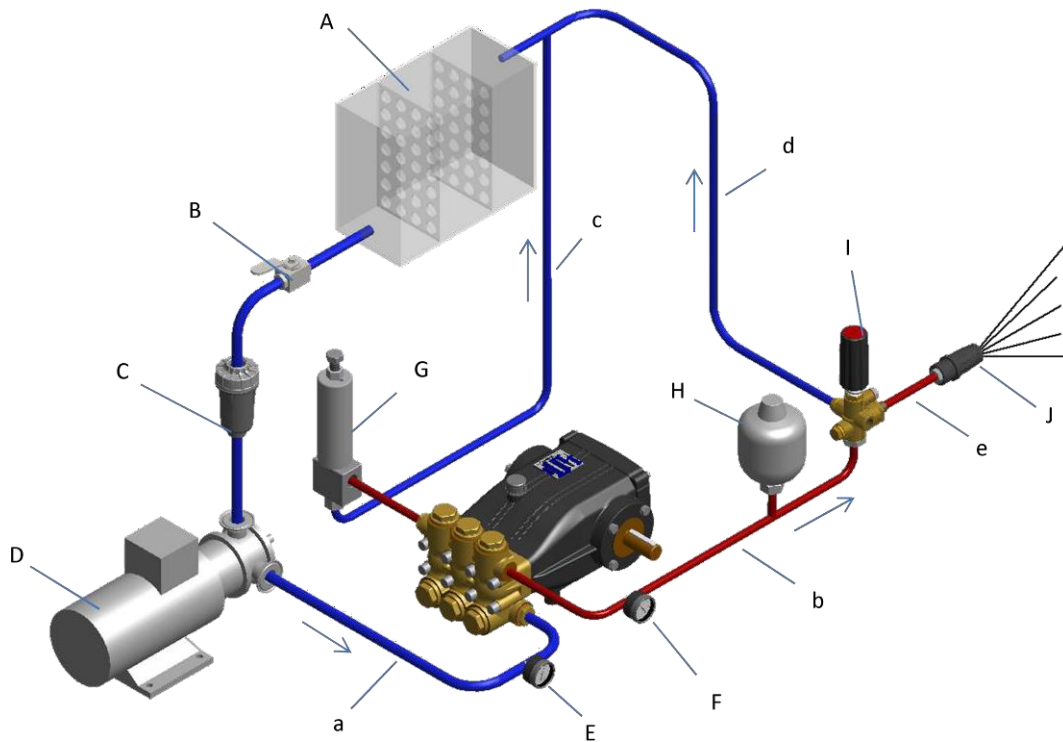

- A) Tank or mains water supply
- B) Shut-off valve
- C) Suction filter
- D) Auxiliary pump
- E) Suction pressure gauge
- F) Delivery pressure gauge
- G) Safety valve
- H) Pressure damper
- I) By-pass and control valve
- J) Nozzle

- a) Supply pipe line
- b) Delivery pipe line
- c) Safety valve release pipe line
- d) By-pass pipe line
- e) Valve outlet pipe line

5.1 Responsibilities of the Customer/User

The customer/User is responsible for:

	<p>Checking the condition of the pump when it is delivered. Contact LEUCO S.p.A. in case of damage or conditions that do not match the purchase order</p>
	<p>The assembler/end user is responsible for choosing the type of motor - pump coupling and for following the instructions in this document.</p>
	<p>The assembler/end user must fit a maximum pressure valve near the pump delivery line outlet.</p>
	<p>The assembler/end user must fit a system that guarantees the hydraulic system will stop immediately in case of a sudden increase in the pump temperature and/or excessive current absorption.</p>

	<p>Follow the instructions provided in the Operating and Maintenance Manual for the machine where the pump is fitted for all connections.</p>
---	--

5.1.1 Placing

The pump must be placed horizontally using the M16 support feet provided.
 The base used must be sufficiently flat and rigid so as to avoid bending and misalignment on the pump/transmission axis due to the output torque transmitted during operation.
 You might also require vibration dampers, to be placed between the floor and the pump support.

The pump is equipped with a lifting hoop to facilitate handling and installation (Figure 1).

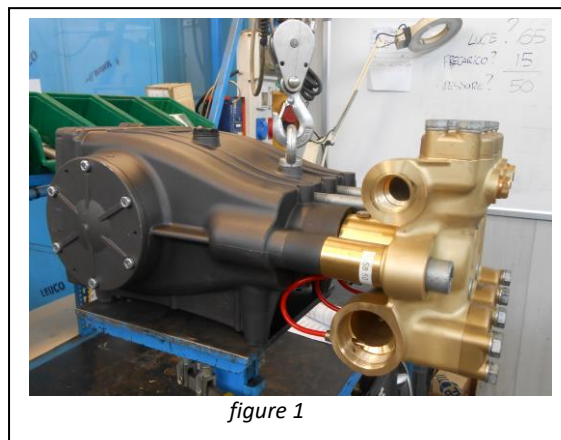



figure 1

	<p>You must replace the crankcase end cap for transportation with the dipstick plug, verifying the correct amount of fluid in the pump.</p>
---	---

The oil level plug must always be accessible with the pump mounted.

	<p>Rigid connections on the pump shaft should be avoided.</p>
---	---

We therefore recommend the following types of transmission:

- Flexible coupling
- Belts and pulleys
- Motion reducer

5.1.2 Rotation direction

The direction in which the pump shaft operates could be indifferent; it is, however, advisable that the operating rotation shown in Figure 2 be applied.

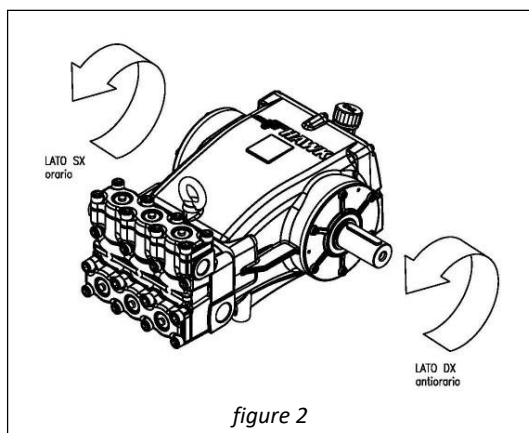

5.1.3 Plumbing connections

We recommend the use of flexible piping to isolate the system from the vibrations induced by the pump. The stiffness of the flexible suction hose should be sufficient to prevent it from becoming deformed due to the depression produced by the pump.

5.1.4 Suction line

In order to ensure smooth operation of the pump, the intake duct should be as described in the following recommendations:

- The pump requires a pressure of 3 bar to work correctly. If a centrifugal pump is used, it must be sized to ensure an intake rate of at least twice the nominal capacity of the pump.
- It should have a diameter that is proportional to the suction port connection; localized narrowing should therefore be avoided as it can generate pressure drop and cavitation phenomena;
- It should maintain as steady and as straight a flow as possible and be made in such a way as to facilitate the evacuation of any air pockets;
- It should be free from leaks and made to ensure tightness over time;
- It should be as free as possible from 90° bends, connections with other pipelines, bottlenecks, counterslopes, inverted U-shaped curves and T-joints;
- It should be designed in such a way as to prevent the circuit from emptying when the pump stops;
- Avoid hydraulic type fittings;
- Avoid the presence of Venturi-type injectors for chemical suction;
- Avoid the presence of foot valves or other one-way valves;
- When connected to a supply tank, ensure that the dimensions of the intake duct are such that no eddies and turbulence are generated in the vicinity of the pump suction pipe outlet;
- It should avoid the use of by-pass valves with direct discharge to suction;
- It should provide any bulkheads inside the suction tank, if any, for the purpose of preventing the flow coming from the by-pass valve from creating eddies and turbulence near the pump suction pipe outlet;
- Ensure the intake duct is always clean.

5.1.5 Filter

Should you plan to install a suction filter on the pump, follow the recommendations below:

- Place the filter as close as possible to the pump and in such a way as to allow easy inspection;
- The minimum flow rate should be three times higher than the pump capacity;
- The diameter of the inlet and outlet should be the same as the pipe and the pump suction pipe outlet;
- Perform regular and frequent cleaning in accordance with the specific working conditions of the application.

5.1.6 Discharge line

The discharge line should be as described in the following rules and recommendations:

- The initial section of the discharge pipe should be made via a flexible hose in order to dampen the vibrations induced by the pump.
- Use high-pressure pipes and fittings to guarantee a wide safety margin in all operating conditions;
- Always ensure the presence of properly-adjusted pressure relief valves;
- It is preferable to use glycerine filled pressure gauges that are designed to withstand the shock loads and water hammers that are typical of piston pumps;
- Always bear in mind that pressure drops along the pipe result in a reduction of the effective pressure at the end of the line compared to the pressure measured at the pump;
- Should the effects of the pulse be particularly harmful, use a pulse damper.

5.2 Pre-commissioning instructions

A series of checks and controls must be completed before starting up the pump for the first time in order to prevent errors or accidents during commissioning:

- That the rotation direction of the pump is correct.
- Always avoid operating the pump under load.
- Always discharge the pressure regulating valve or use the discharge mechanisms, where present.
- Check that the speed does not exceed the value indicated on the nameplate.
- Wait a few minutes before pressurizing the circuit, making sure that the pump is sucking properly.
- Before stopping the pump, reset the pressure to zero by discharging the pressure regulating valve or using the circuit's discharge mechanisms, where present. If the pump is coupled to an endothermic motor, bring the motor down to its lowest speed before stopping it altogether.
- Where there is a feed pump on the suction circuit, wait until it has reached the expected pressure before starting up the piston pump.



If the equipment does not appear capable of running safely and correctly, TAKE IT OUT OF SERVICE until it has been repaired or any damaged parts have been replaced.

5.3 Long periods of inactivity

In case of long periods of inactivity, follow the instructions below:

- Run the pump with clean water for several minutes.
- Run the pump dry for about 10 seconds with the delivery line open (lance) to drain the pump and the delivery circuit and prevent the formation of scale.
- Clean the pump with water and solvents authorised by current legal standards.
- Dry the pump using compressed air.
- Grease any unpainted parts.
- Do not let the system come into contact with corrosive substances.



The properties of mineral oils are impaired if they are not used or remain inactive for more than six months, and so must be replaced.





When resuming operation of the machine after a long period of inactivity, repeat the checks carried out prior to the initial start up (section 5.2). Also check the screws and the level of the oil.

5.4 Operation

Before each start-up, you must ensure that:

- The suction line is connected and full as the pump must never run dry.
- There are no leaks.
- Any shut-off valves on the suction circuit are open and the water can freely enter the pump.
- The discharge line is an open drain type in order to ensure the speedy evacuation of air in the circuit, thereby encouraging pump priming.
- All fittings and connections are properly tightened.
- The pump/transmission alignment is properly aligned.
- The oil level inside the crankcase is correct; this can be checked by means of the dipstick found in the airtight stopper cap or by looking at the oil level indicator light.

	<p>Poor supply can cause serious damage to the pump, such as priming problems, vibration, noise and short seal life.</p>
	<p>The pump should not be used at higher pressures or speeds of rotation than those shown on the product's specifications plate.</p>

NOZZLE TABLE: the table below is an example of how to choose the nozzle correctly based on the pump's specifications (maximum pressure and flow rate factor). The table gives an example (pump with Pmax=100 bar and Flow Rate =15 l/min).

Select the pressure in the first line and go down the table to the flow rate factor that is closest to that of the pump, rounded down, to get the best type of nozzle to achieve the values followed. To be sure the pressure ratings will remain constant over time, choose a nozzle matching the flow rate factor immediately below the next one (in the example, the value is circled in green).



FATTORE PORTATA	PORTATA (L/MIN) ALLA PRESSIONE (BAR)												PORTATA (L/MIN) ALLA PRESSIONE (BAR)												
	BAR	50	60	70	80	90	100	110	120	130	140	150	160	170	180	190	200	220	240	250	280	300	320	350	
O2	3,3	3,6	3,8	4,1	4,4	4,6	4,8	5,0	5,2	5,4	5,6	5,8	6,0	6,2	6,3	6,5	6,8	7,1	7,3	7,7	8,0	8,2	8,6		
O3	4,8	5,3	5,7	6,1	6,5	6,8	7,1	7,4	7,8	8,0	8,3	8,6	8,9	9,1	9,4	9,6	10,1	10,5	10,8	11,4	11,8	12,2	12,7		
O4	6,4	7,0	7,6	8,1	8,6	9,1	9,5	10,0	10,4	10,8	11,1	11,5	11,9	12,2	12,5	12,9	13,5	14,1	14,4	15,2	15,8	16,3	17,0		
O45	7,3	8,0	8,6	9,2	9,8	10,3	10,8	11,3	11,7	12,2	12,6	13,0	13,4	13,8	14,2	14,6	15,3	16,0	16,3	17,2	17,8	18,4	19,3		
O5	8,1	8,8	9,5	10,2	10,8	11,4	12,0	12,5	13,0	13,5	14,0	14,4	14,9	15,3	15,7	16,1	16,9	17,7	18,0	19,1	19,7	20,4	21,3		
O55	8,8	9,7	10,5	11,2	11,9	12,5	13,1	13,7	14,3	14,8	15,3	15,8	16,3	16,8	17,2	17,7	18,5	19,4	19,8	20,9	21,7	22,4	23,4		
O6	9,7	10,6	11,5	12,3	13,0	13,7	14,4	15,0	15,6	16,2	16,8	17,3	17,9	18,4	18,9	19,4	20,3	21,2	21,7	22,9	23,7	24,5	25,6		
O65	10,5	11,5	12,4	13,2	14,0	14,8	15,5	16,2	16,9	17,5	18,1	18,7	19,3	19,9	20,4	20,9	22,0	22,9	23,4	24,8	25,6	26,5	27,7		
O7	11,3	12,4	13,4	14,3	15,2	16,0	16,8	17,5	18,2	18,9	19,6	20,2	20,9	21,5	22,1	22,6	23,7	24,8	25,3	26,8	27,7	28,6	29,9		
O75	12,1	13,2	14,3	15,3	16,2	17,1	17,9	18,7	19,5	20,2	20,9	21,6	22,3	22,9	23,6	24,2	25,4	26,5	27,0	28,6	29,6	30,6	32,0		
O8	12,9	14,1	15,2	16,3	17,3	18,2	19,1	19,9	20,8	21,5	22,3	23,0	23,7	24,4	25,1	25,7	27,0	28,2	28,8	30,5	31,5	32,6	34,0		
O85	13,7	15,0	16,2	17,4	18,4	19,4	20,3	21,3	22,1	23,0	23,8	24,5	25,3	26,0	26,7	27,4	28,8	30,1	30,7	32,5	33,6	34,7	36,3		
O9	14,8	16,3	17,6	18,8	19,9	21,0	22,0	23,0	23,9	24,8	25,7	26,6	27,4	28,2	28,9	29,7	31,1	32,5	33,2	35,1	36,4	37,6	39,3		
O95	15,6	17,0	18,4	19,7	20,9	22,0	23,1	24,1	25,1	26,0	26,9	27,8	28,7	29,5	30,3	31,1	32,6	34,1	34,8	36,8	38,1	39,4	41,2		
10	16,3	17,8	19,2	20,6	21,8	23,0	24,1	25,2	26,2	27,2	28,2	29,1	30,0	30,9	31,7	32,5	34,1	35,6	36,4	38,5	39,8	41,1	43,0		
11	17,7	19,4	20,9	22,4	23,7	25,0	26,2	27,4	28,5	29,6	30,6	31,6	32,6	33,5	34,5	35,4	37,1	38,7	39,5	41,8	43,3	44,7	46,8		
115	18,4	20,1	21,8	23,3	24,7	26,0	27,3	28,5	29,6	30,8	31,8	32,9	33,9	34,9	35,8	36,8	38,6	40,3	41,1	43,5	45,0	46,5	48,6		
12	19,1	20,9	22,6	24,1	25,6	27,0	28,3	29,6	30,8	31,9	33,1	34,2	35,2	36,2	37,2	38,2	40,0	41,8	42,7	45,2	46,8	48,3	50,5		
125	19,8	21,7	23,4	25,0	26,6	28,0	29,4	30,7	31,9	33,1	34,3	35,4	36,5	37,6	38,6	39,6	41,5	43,4	44,3	46,9	48,5	50,1	52,4		
13	21,2	23,2	25,1	26,8	28,5	30,0	31,5	32,9	34,2	35,5	36,7	37,9	39,1	40,2	41,4	42,4	44,5	46,5	47,4	50,2	52,0	53,7	56,1		
14	22,6	24,8	26,8	28,6	30,4	32,0	33,6	35,1	36,5	37,9	39,2	40,5	41,7	42,9	44,1	45,3	47,5	49,6	50,6	53,5	55,4	57,2	59,9		
15	24,0	26,3	28,4	30,4	32,3	34,0	35,7	37,2	38,8	40,2	41,6	43,0	44,3	45,6	46,9	48,1	50,4	52,7	53,8	56,9	58,9	60,8	63,6		
16	25,5	27,9	30,1	32,2	34,2	36,0	37,8	39,4	41,0	42,6	44,1	45,5	46,9	48,3	49,6	50,9	53,4	55,8	56,9	60,2	62,4	64,4	67,3		
18	29,0	31,8	34,3	36,7	38,9	41,0	43,0	44,9	46,7	48,5	50,2	51,9	53,5	55,0	56,5	58,0	60,8	63,5	64,8	68,6	71,0	73,3	76,7		
20	32,5	35,6	38,5	41,1	43,6	46,0	48,2	50,4	52,4	54,4	56,3	58,2	60,0	61,7	63,4	65,1	68,2	71,3	72,7	77,0	79,7	82,3	86,1		
25	31,2	36,0	40,3	44,2	47,7	51,0	54,1	57,0	59,8	62,4	65,0	67,4	69,8	72,1	74,3	76,5	80,6	84,5	86,4	91,9	95,4	98,7	103,5		

6 MAINTENANCE

Use the special tools provided in the product's tool-kit for pump maintenance, as this will facilitate the maintenance of certain parts. If the special tool-kit is not available, standard tools can be used (screwdrivers, pin punches, etc. but take care not to damage the pump's parts.

Follow the instructions below during maintenance or repairs:

- Before starting work, hang a "**MACHINE UNDERGOING MAINTENANCE**" sign in a prominent position
- Do not use flammable products or materials
- When handling lubricants, wear gloves that are resistant to mineral oils, overalls (trousers must never be tucked into safety shoes) and goggles
- Do not spill any oil or lubricant

	Maintenance work may only be carried out by authorised, qualified personnel and must be noted in the special log.
	Always comply with the safety instructions in section 3.

The pump's efficiency can be safeguarded by following the preventive maintenance schedule below:

CONTROL	DAILY	WEEKLY	50 H	500 H	1000 H
CLEAN FILTERS	X				
OIL LEVEL/CONDITION	X				
OIL/WATER LEAKS	X				
HYDRAULIC SYSTEM		X			
1st OIL CHANGE			X		
CHANGE OIL				X	X
REPLACE SEALS					X
REPLACE CHECK VALVES					X

* Each maintenance schedule depends on the type of job that the pump is used for.

The operating cycle, the temperature and the quality of the pumped liquid, the type and quality of the supply and the condition of the accessories used are all fundamental factors that influence the life of pump parts.

The schedule indicated for the routine maintenance in the table should be reduced by 50% in case of high temperature pumps.

After completing any maintenance work, remember to adjust the control / unloader / safety valve and check the condition of the hydraulic system and relative couplings.

The data provided is the result of the cycles verified on our testing benches, therefore any other element that differs to the parameters used may have an impact on the life of the parts.

The first oil change is to be carried out after 50 hours of operation and then every 1000 hours, or once a year. The required amount is 5.5 litres.

6.1 General maintenance

Generally speaking, the following checks must be carried out: Check the pump is secured properly:

- ✓ Check the screws securing the pump are tight
- ✓ If necessary, tighten the screws using the torque indicated in the installation diagram.

Check pipes and couplings:

- ✓ Check for any leaks from the couplings
Leaks can usually be remedied by tightening the couplings properly
Leaks from the couplings on the suction pipes are remedied by repairing the seal
- ✓ Check the condition of the hoses.
Replace the hoses if they look old, damaged, bulging or worn etc.

Check the filter (not supplied by LEUCO):

- ✓ Check the condition of the filter cartridge.
Refer to the filter manufacturer's instructions if the filter cartridge is clogged or damaged in order to restore the original performance of the filter cartridge.

Checking the oil level:

- ✓ Check the level when the pump is cold and on a level surface.
- ✓ Check the amount of oil using the level indicator (located on the rear of the pump body, see section 2.1, letter G).
- ✓ If necessary, top up with oil as indicated in section 3.7, through the oil plug (located in the upper part of the pump body, see section 2.1, letter C).

Change the oil:

- ✓ Put the machine where the pump is fitted on a perfectly level surface with the pump slightly warm. Do not spill any oil.
Dispose of oil according to current legal requirements.
- ✓ Have a suitably large container ready for the old oil.
- ✓ Unscrew the drain plug (1) and let all the oil drain out completely.
- ✓ Replace the drain plug.
- ✓ Unscrew the oil plug (letter C, section 2.1 or 2 in the figure below).
- ✓ Pour new oil into the filling hole up to the correct level (as described in the section on "Checking the level of oil").
- ✓ Replace the filling cap.

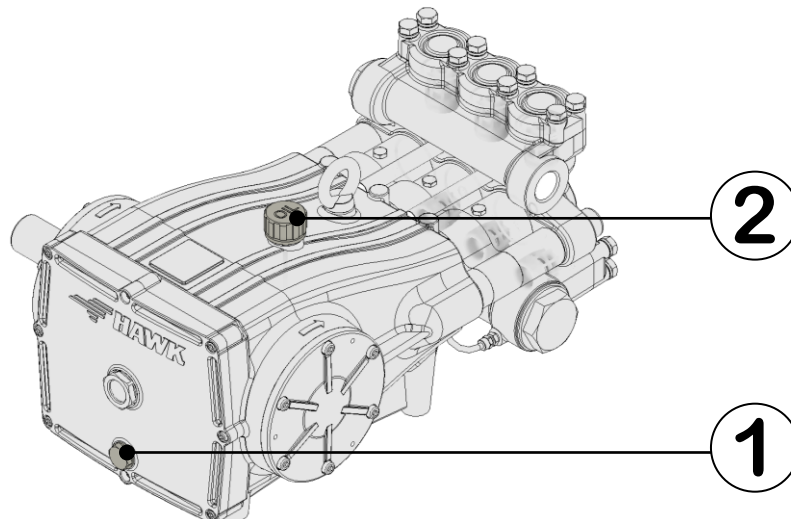

You must find the cause of any abnormality and remedy it before the machine can be put back into operation.



**For other maintenance, comply with any other instructions and/or procedures in use at the company or described in the operating manual of the final machine (high pressure cleaner).
Before undertaking any other maintenance (not described in this manual or its attachments) contact the Manufacturer**

6.2 Removal of mechanical parts

Remove parts as described below:

- Empty the oil out of the crankcase through the drain plug;
- Remove the key from the shaft;
- Remove the cylinder head;
- Remove the back cover;
- Unscrew the connecting rod feet, making sure you remember the position of each one in relation to its connecting rod (Figure 3);
- Press the connecting rods towards the bottom of the crankcase;
- Unscrew the bearing housings and take them off the crankcase;
- Take the shaft out from the side through the housing hole on the PTO side;
- The ceramic plunger and spray washer must first be removed before the plunger rods and their connecting rods can be removed.

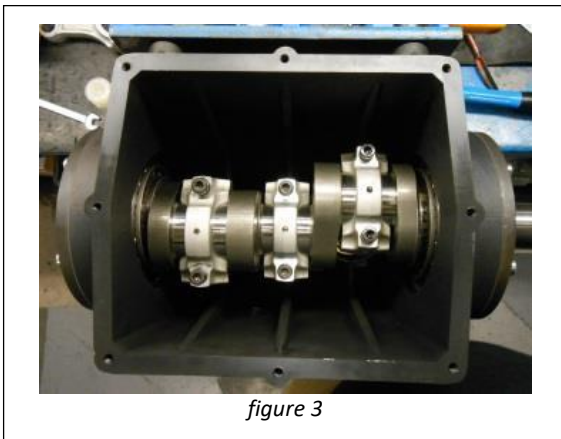

figure 3

6.3 Assembly of mechanical parts

The mechanical parts are reassembled as follows:

- Replace the plunger rods with their connecting rods if they were removed, pressing them down to the bottom of the crankcase;
- Insert the shaft at the side through the housing hole on the PTO side, making sure the PTO remains on the required side of the crankcase (the shaft should still be inserted on the side without the PTO, supporting this with your hand);
- Replace the oil seal if it is worn and then insert the two bearing housings in the crankcase holes, remembering to check the wear rings are fitted. Tighten the 6 screws by applying 20 Nm torque;
- Replace the connecting rod feet, taking care not to swap their positions and respecting the torque of 38 Nm;
- Fit new oil seals on the plunger rod, if the latter were replaced;
- Replace the rear cover and tighten the screws by applying 10 Nm torque;
- Replace the plungers fitted with the splash washers if they were removed in order to remove the connecting rods and their rods, tightening the plunger screws by applying 20 Nm torque;
- Replace the manifold housing as instructed in section "6.6.2 Replacing the seals";
- Replace the shaft key.

6.4 Inspecting the bearings

After having disassembled the mechanical part, as described in the previous point, you should proceed to visually inspect the rollers and their tracks.

Unless any abnormal wear is noted, proceed to clean the rollers and tracks with a solvent; once that is done, cover them with a thin layer of lubricating oil (the same as the oil contained in the crankcase).

Once this operation is complete, you may replace the mechanical part as shown above.

If, on the other hand, the tracks or rollers show signs of wear, replace them as specified in the next step.

6.5 Changing the bearings

Once the bearing housings and the shaft have been removed as instructed above, take the outer bearing ring nuts off their respective housings and the internal ring nuts off the shaft using a pin punch or similar tool. The new bearings can be fitted using a press or fly press, using the proper rings to help you. Do not swap the outer bearing ring nuts when fitting them inside the housings.

6.6 Maintenance of the hydraulic part

Maintenance of the hydraulic part concerns the replacement of the suction/delivery valves and seals whenever a water leakage is found or in any case in the event of a significant reduction in flow rate (and therefore the maximum working pressure of the pump). For routine maintenance intervals refer to chap. 6.

6.6.1 Replacement of suction/delivery valves

DISMANTLING

To replace the suction/delivery valves in the head, proceed as follows:

- Unscrew the 8+8 M12 screws securing the VAM covers (suction and discharge) and remove them (Figure 4, Figure 5)
- Using a threaded rod to the ends of which is screwed the top of the VAM cap on one side and a limit nut on the other, proceed to extract this cap using a drilled cylinder sliding along this threaded rod (Figure 6, Figure 7, Figure 8, Figure 9, Figure 10).
- Using the same technique, but this time with an M8 (or M6 depending on the model) bar, extract the VAM cage (Figure 11). Use pliers to pull out the other components of the valve.
- Use pliers to pull out the other components of the valve. Repeat the operation described above for all the other VAM.

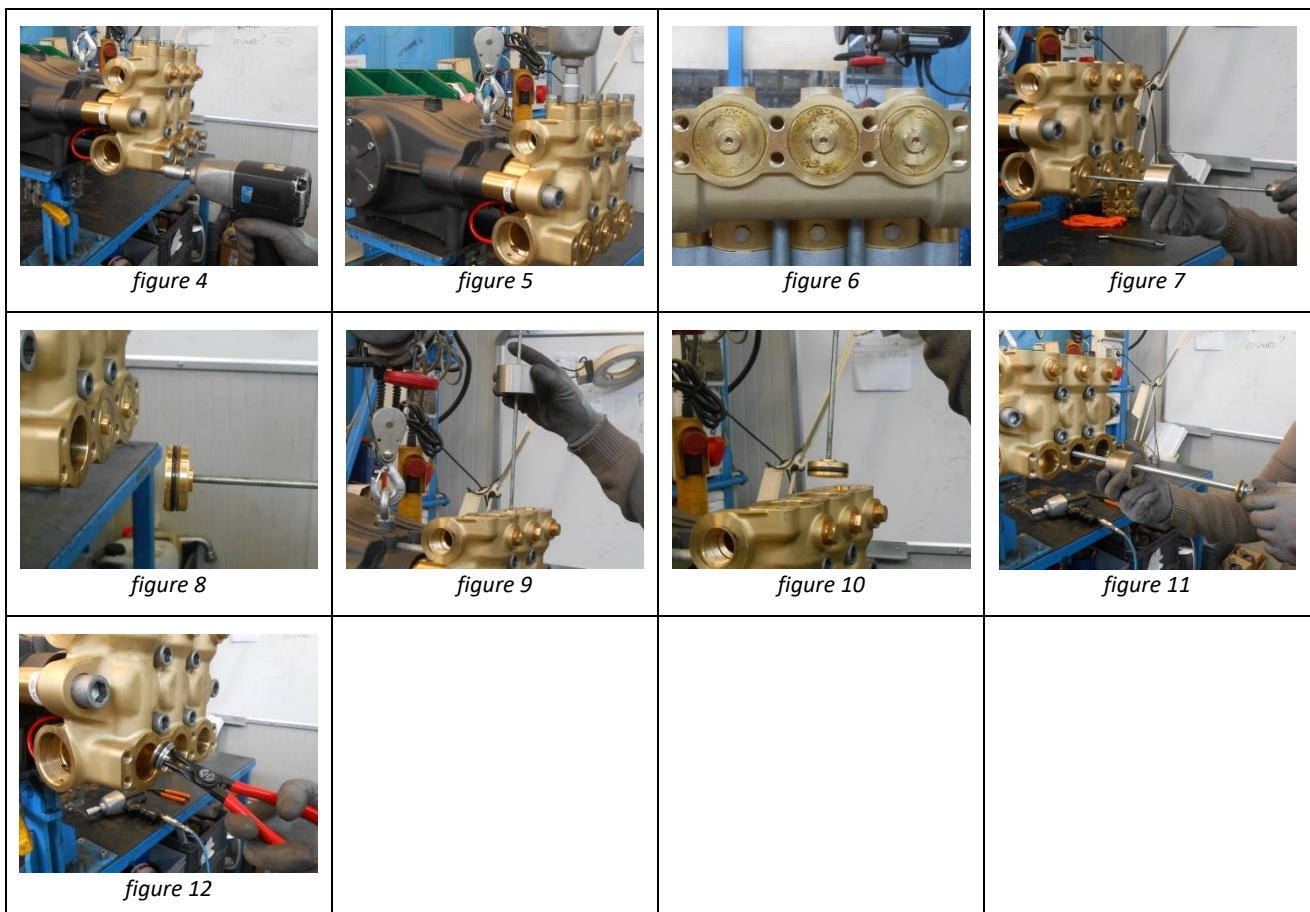

ASSEMBLY

- Generously grease all VAM seats inside the header. (Figure 13)
- Insert the new VAMs (Figure 14, Figure 15).
- Insert the VAM plugs (Figure 16).
- Mount the 2 suction and discharge covers by screwing them on with a socket spanner. (Figure 18)
- Mount the 2 suction and discharge covers by screwing them on with a socket spanner. (Figure 19)



figure 13



figure 14



figure 15



figure 16



figure 17



figure 18



figure 19

6.6.2 Replacement of the seals

To replace the seals, proceed as follows:

DISMANTLING

- Unscrew the recirculation pipe connected between the head and the seal support bushing. (Figure 20)
- Unscrew the 4 M16 hex screws and 2 M20 fixing the head to the casing. (Figure 21, Figure 22)
- Remove the two lateral brass spacers. (Figure 23)
- Remove the cylinder head using a plastic hammer. (Figure 24)
- Use a crank to facilitate the removal of the gasket-holder bushings, pressers and anti-extrusion rings. (Figure 25, Figure 26, Figure 27)
- Remove the crankcase spacer. (Figure 28)
- Remove the low-pressure seal using a plastic tool to prevent damage to the brass seat. (Figure 31) If one or more bushings still have a presser and extruder inside, remove them manually. (Figure 29, Figure 30)
- Use a pin driver to remove the piston guide bushing. (Figure 33)
- Remove the high-pressure gasket pack.

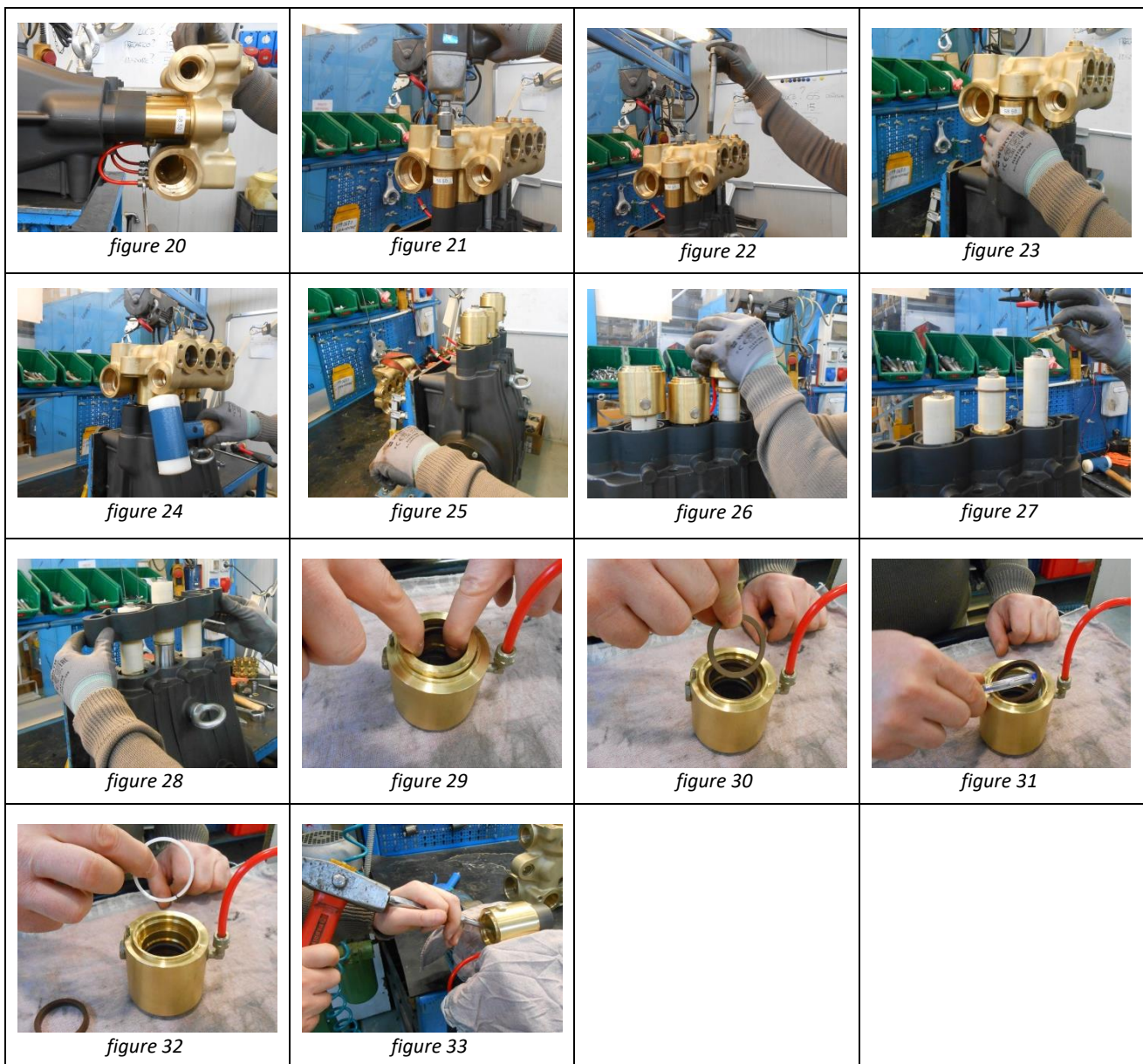

ASSEMBLY

- Apply plenty of grease to the gasket bushings. (Figure 34)
- Apply thread sealant to the two threaded holes in the brass bushing. (Figure 35)
- **Pay attention to the direction of the 90° connection. (Figure 36.a)**
- Insert the plastic ring "A" (Figure 37a) and the low-pressure seal "B" (Figure 37a) using the dedicated tool in the tool-kit. (Figure 38, Figure 39, Figure 40, Figure 41).
- For some versions, the lower package is reduced to the installation of just the gasket (Figure 42).
- Insert the head spacer with the pin holes facing upwards. (Figure 43, Figure 44 circle in red)
- Insert the presser "D" (Figure 37a) and the low-pressure anti-extrusion device "C" (Figure 37a) into the piston and grease them thoroughly. (Figure 44)
- Fit the three brass gasket bushings, inserting the pin into the hole of the spacer. (Figure 45)
- Insert the high-pressure gasket pack into the piston in the following order: anti-extrusion "E", gasket "F" and plastic ring "G". (Figure 46)
- Insert the piston scraper ring into the plastic bushing (Figure 47.a)
The TXT2214 model, on the other hand, features a double gasket and "V" without piston ring. (Figure 47.b)
- Insert the OR into the respective seat of the head (Figure 48)
- For TXT 2214, insert anti-extrusion and OR into the outer grooves of the brass bushings and grease them. (Figure 49, Figure 50, Figure 51, Figure 52 **Before mounting the high-extruder, deform it. (Figure 50)**)
- Gently place the header on the glasses. (Figure 53)
- Mount the two side spacers and position the 2 M20 screws. (Figure 54)
- Insert the 4 central M20 screws and screw them in by hand as far as they will go. (Figure 55)
- Proceed in the same way with the side screws.
- Tighten all screws to a torque of 140 Nm. Further tighten the side ones to 160 Nm (Figure 56)

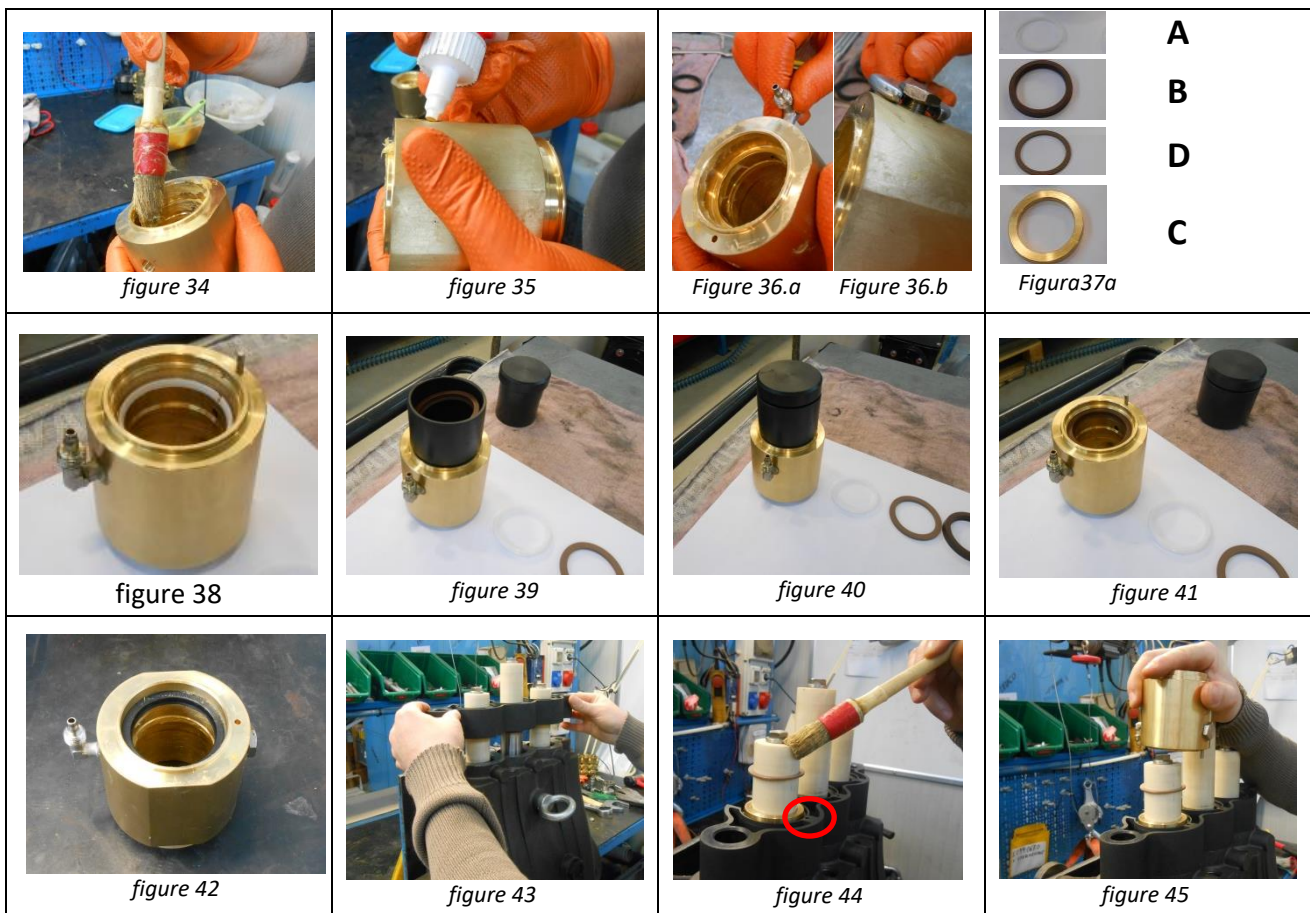

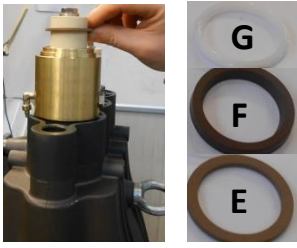

figure 46



figure 47.a

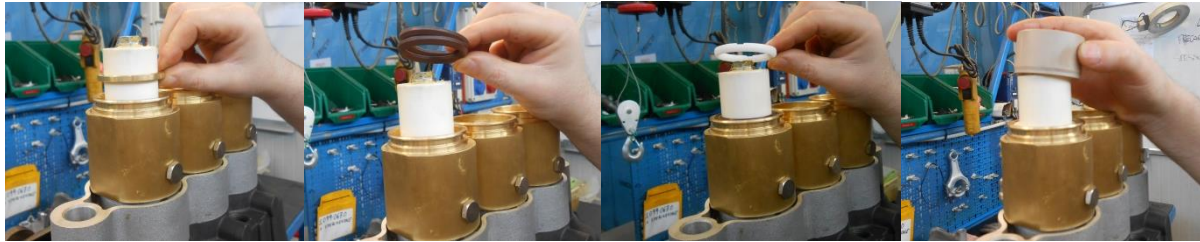

figure 47.b



figure 48



figure 49



figure 50



figure 51

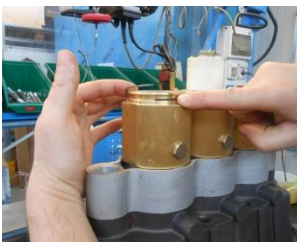

figure 52



figure 53

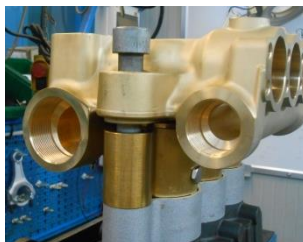

figure 54



figure 55



figure 56

6.6.3 Replacing the plungers

If one or more plungers need replacing, follow the instructions below:

DISMANTLING

- After removing the manifold housing as described at the beginning of section 6.6.2, unscrew the plunger nuts using the appropriate key.
- Once the individual pistons have been removed, remove the nut with the aid of a hammer and pliers. (Figure 58, Figure 59)

ASSEMBLY

- Apply a suitable threadlocker to the threaded rod (Figure 60)
- Pre-assemble the nut in the piston hole, paying attention to the correct insertion of the O-ring (Figure 61)
- Finally, tighten the piston nut to a torque of 20 Nm.

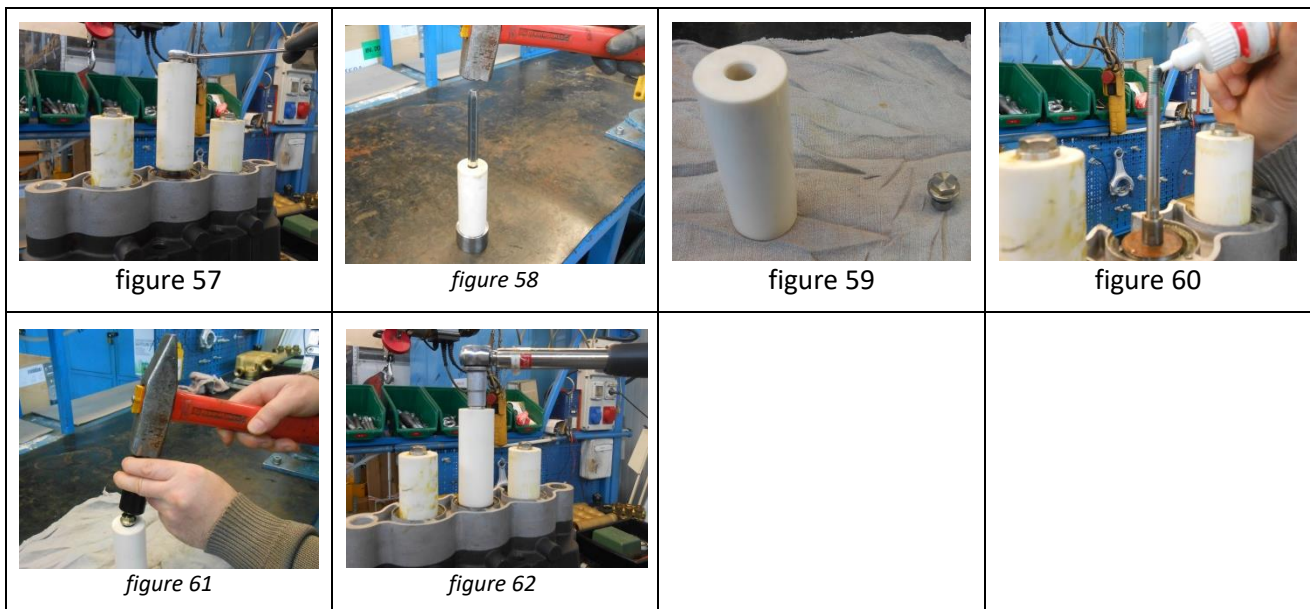

7 TROUBLESHOOTING

7.1 Problems and potential remedies



Only authorised and qualified personnel may attempt troubleshooting.

This section suggests some solutions to common problems or malfunctions that may occur.

Some of the suggested solutions may be carried out by experienced personnel; others should only be attempted by Authorised Service Centres as they require the use of specific tools as well as detailed knowledge of repairs.



Contact the Manufacturer for instructions if any faults are found on the machine or its parts and you are unable to solve the problem.

PROBLEMS	POSSIBLE CAUSES	SOLUTIONS
The pump runs but does not produce noise or pressure	The pump is not primed and is running dry	Check if there is water in the suction line Check if the delivery line (gun) is open Check the valves are NOT blocked

PROBLEMS	POSSIBLE CAUSES	SOLUTIONS
The pump runs but is too noisy and/or does not reach the expected pressure	Oversized or worn nozzle Insufficient water supply	Replace the nozzle Clean the filter. Replace the filter with an appropriately sized filter. Eliminate any possible intake of air. Check the size of the suction pipe and replace with a larger diameter pipe, if necessary.
	Pressure control valve is not calibrated or working properly.	Calibrate the valve.
	Worn piston seals	Check the status of the seat of the seal. Replace the seals
	Low speed of rotation	Check the motor and the drive
The pump comes up to pressure	Foreign matter in the valves	Clean the valves
	Worn valves	Replace the valves
	High inlet water temperature	Reduce the water temperature
	Worn piston seals	Replace the seals
The pump is very noisy	Worn bearings	Replace the bearings
	High inlet water temperature	Reduce the water temperature
	Pump-motor coupling problems	Check the status of the keys and the flexible coupling or the pulley
Short piston seal life	Cavitation or air in the system	Check the state and size of the suction pipe and replace with a larger diameter pipe, if necessary.
	Damaged ceramic piston	Replace the piston
	Excessive pressure and/or temperature of the pumped water	Check the pressure and the temperature of the inflowing water
Water in the oil	Worn plunger – oil shaft seal ring. If the oil is milky (emulsified), but the level does not increase in the crankcase, this means that only condensation is present.	Replace the ring seal Change the oil more frequently
Water leaking between the crankcase and the manifold housing	Worn seal pack	Replace seal pack
	Worn piston	Replace piston
	Worn piston bolt seal	Replace seal
Oil leaking between the crankcase and the manifold housing	Worn piston - shaft oil seal	Replace the seal
Short bearing life	Pump-motor coupling problems	Check the status of the keys and the flexible coupling or the pulley
	The oil has not been changed regularly	Change the oil according to the instructions in the pump manual
	Excessive pressure of the pumped water	Check the pressure

8 DISMANTLING AND DISPOSAL



Contact the Manufacturer for information and instructions before dismantling the pump in order to move it or for its disposal, as applicable.

Only qualified personnel are allowed to dispose of the pump in accordance with current legislation on safety at work. Any parts removed must be separated for recycling according to the type of materials they are made of. Do not dump hazardous waste, including seals and lubricants, into the environment. Any non-ferrous parts must be disposed of by an authorised company. Any parts made of iron can be recycled or sold. The manufacturer must be notified if the machine is decommissioned or sold.

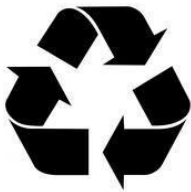

The packing materials can be recycled. Do not throw the packing materials away with normal household waste, but send them for recycling.

The pump contains important raw materials that can be recycled and so they should be sent for recycling to make sure they will be used again. Do not throw oil away down the drain.

Dispose of the pump properly at an authorised waste disposal centre.

9 SPARE PARTS

Always use original spare parts (Attachment II).

10 ATTACHMENTS

- I. Declaration of incorporation www.hawkpump.com → download
- II. Technical characteristics www.hawkpump.com → pumps
- III. Coupling systems www.hawkpump.com → accessories