

INSTRUCTION MANUAL

Version 001-21
ORIGINAL INSTRUCTION

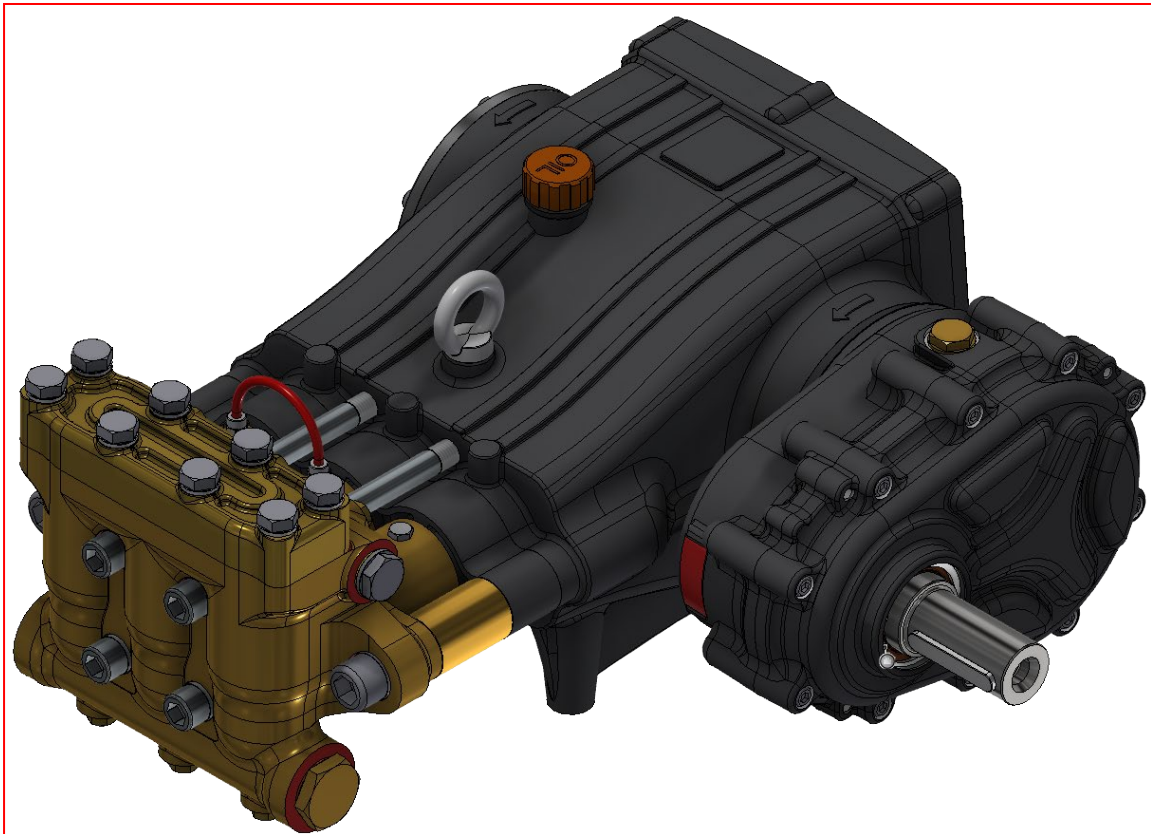

**55 kW GEARBOX FOR PUMPS SERIES
GXT-GPX-GXX -TXT-TPX**

LEUCO S.p.A.

Via Colletta, 20
42124 Reggio Emilia (RE) - ITALY
Tel. 0522/923011 Fax 0522/923030

This manual and associated information can be downloaded from the website: www.hawkpumps.com

This manual is an integral part of the product and should always be made available to any persons using it

CONTENTS

1.	EXPLODED VIEW OF PARTS.....	3
2.	INTRODUCTION	5
3.	GENERAL DESCRIPTION	5
4.	DIRECTION OF ROTATION.....	6
5.	CHOISE OF GEAR RATIO	6
6.	DIMENSIONS AND POSITIONS	7
7.	NECESSARY TOOLS.....	8
8.	INSTALLATION AND ASSEMBLY	9
8.1	<i>Assembly instructions</i>	Errore. Il segnalibro non è definito.
8.2	<i>Removal of mechanical parts</i>	1
9.	REGULAR MAINTENANCE	14

1. EXPLODED VIEW OF PARTS

POS.	P/N	DESCRIZIONE	Q.tà
1	9.853-862.0	SNAP RING Ø68 UNI7437	1
2	9.853-864.0	OIL SEAL	1
3	9.853-852.0	COVER	1
4	9.851-597.0	SCREW M8x50 12.9	16
5	9.851-157.0	WASHER M8	10
6	9.853-868.0	BALL BEARING 6310	1
7	9.853-863.0	SCREW M16x40	1
8	9.853-861.0	WASHER 62x17.6	1
9	9.850-449.0	KEY 12x8x70	1
10	9.853-855.0	PINION Z=25	1
	9.853-857.0	PINION Z=22	
	9.853-859.0	PINION Z=19	
11	9.853-856.0	GEAR Z=37	1
	9.853-858.0	GEAR Z=40	
	9.853-860.0	GEAR Z=43	
12	9.853-866.0	OR 2.62x221.93	1
13	9.851-118.0	COPPER WASHER M8	6
14	9.853-867.0	BALL BEARING 6309	1
15	9.853-869.0	PIN Ø5	2
16	9.851-304.0	BRASS CAP G ½"	2
17	9.850-673.0	O-RING 3068 - Ø2,62x17,13	2
18	9.853-853.0	GEAR HOUSING	1
19	9.853-854.0	PAPER SEAL	1
20	9.853-889.0	DOUBLE LIP OIL SEAL	1

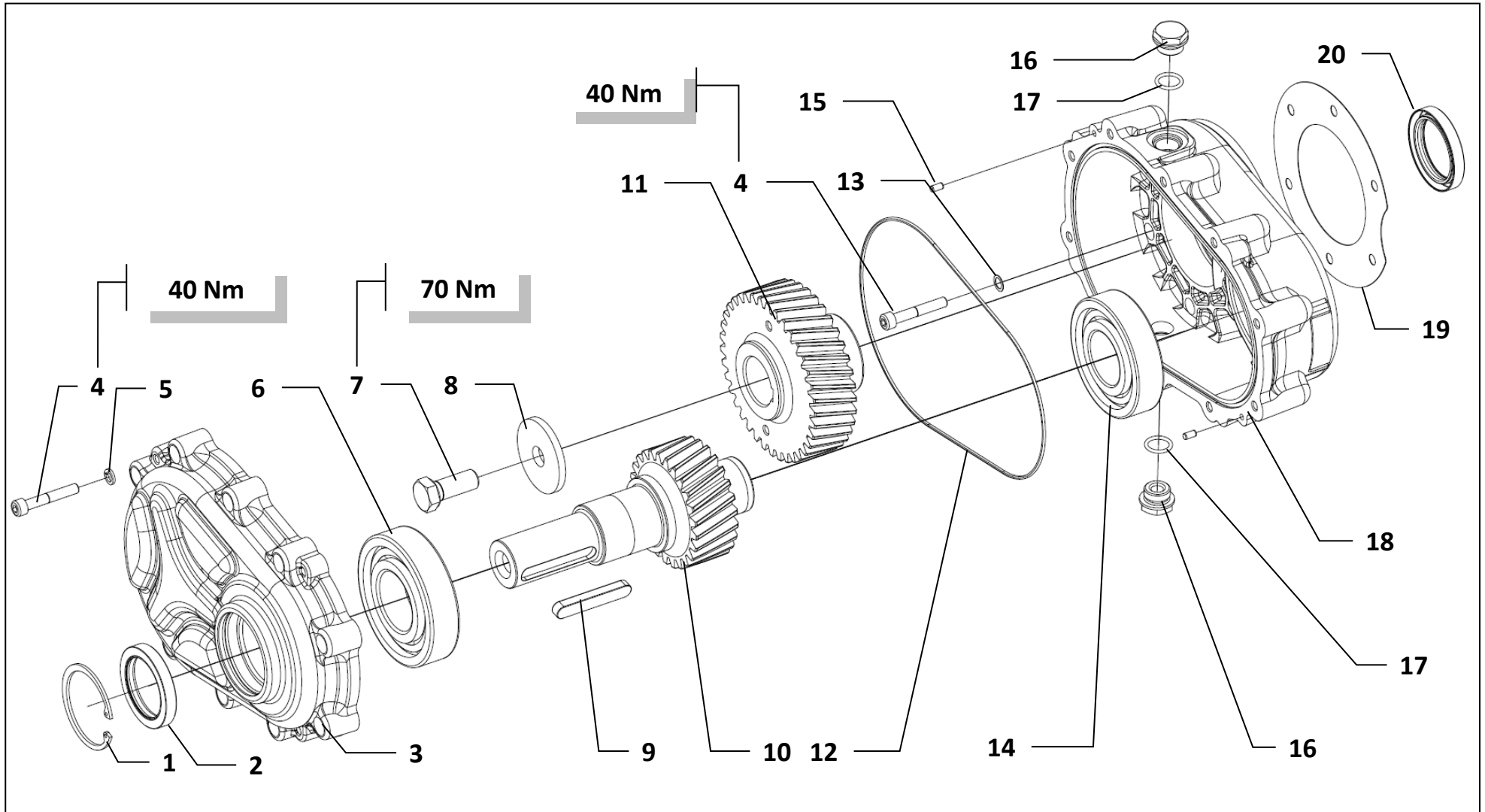









2. INTRODUCTION

Below are reported the instructions to mount the gear unit for GXT – GPX – GXX - TXT –TPX pumps. It is recommended:

- 2.1 carefully read the pump manual in order to avoid functional problems otherwise LEUCO doesn't assume any responsibility.
- 2.2 To assume safety precaution for all mounting and operating conditions
- 2.3 Check if all components listed in the exploded view are supplied into the packaging.

3. GENERAL DESCRIPTION

 	Don't exceed pump maximum speed (1000 rpm).
 	Don't release oil in the environment but raise it in the proper containers.
 	Install a flexible coupling between the motor and the gearbox pinion.
 	Don't use belts and pulleys.

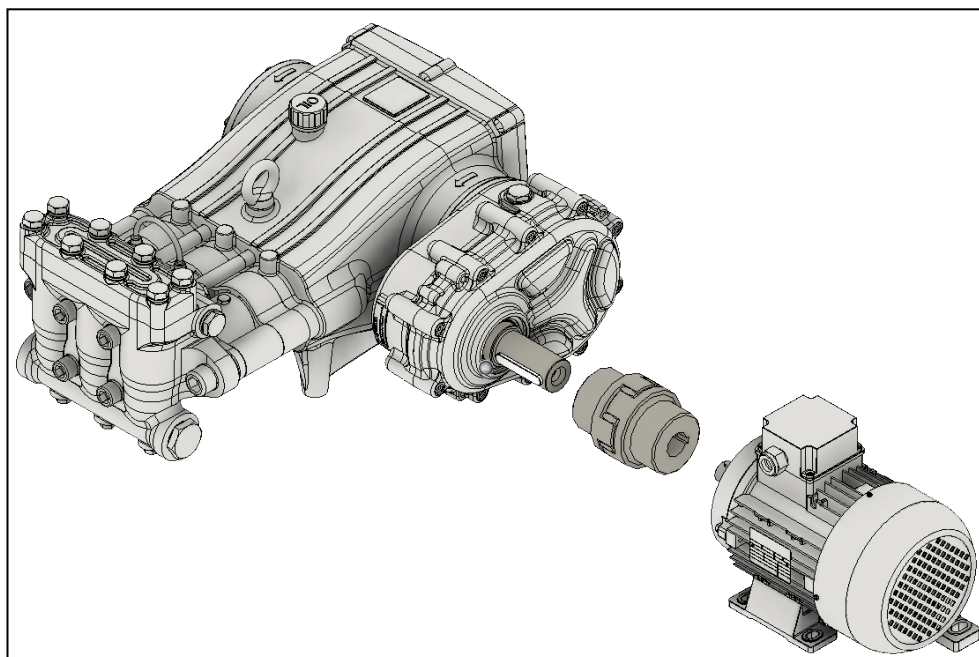

4. 4. DIRECTION OF ROTATION



The direction of rotation of the gearbox is indicated in the picture below.

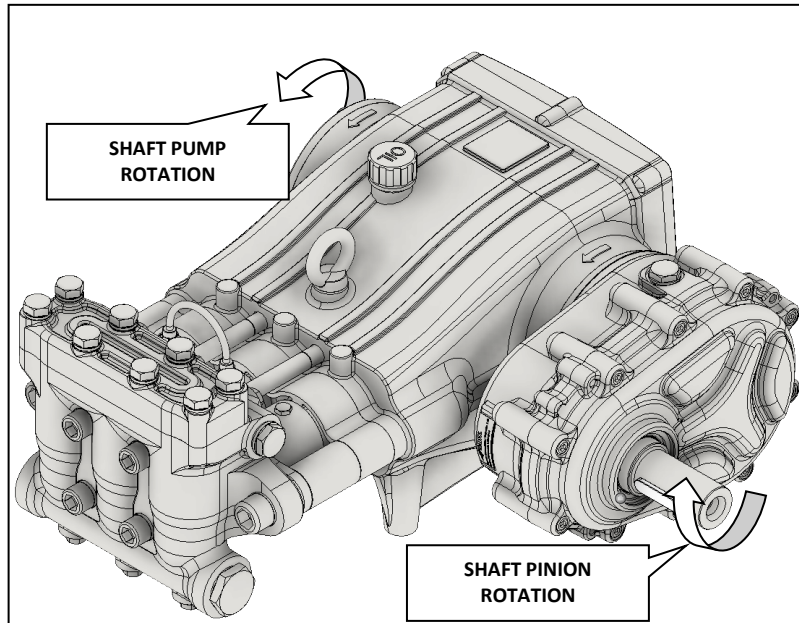

5. CHOISE OF THE GEAR RATIO

Providing an exact description of the pump, model, serial number and technical data makes it easier for the technical personnel to deliver a fast and efficient service (if needed).

The identification data is reported on the label attached to the equipment, as shown below.



Do not remove (or change the position) of any type of id plate and/or labels containing information and/or warning notices on the equipment.

FAC – SIMILE

Pump label

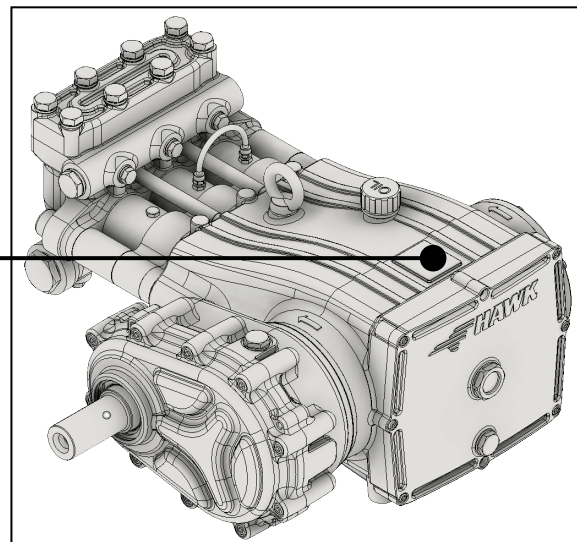
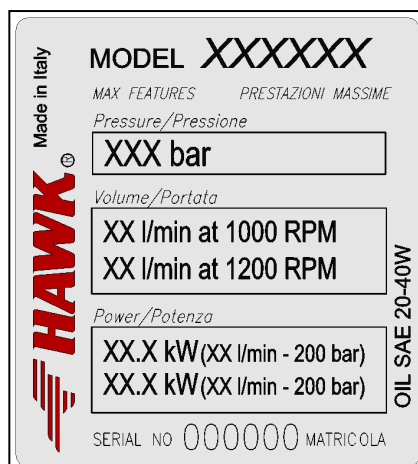

Gearbox label

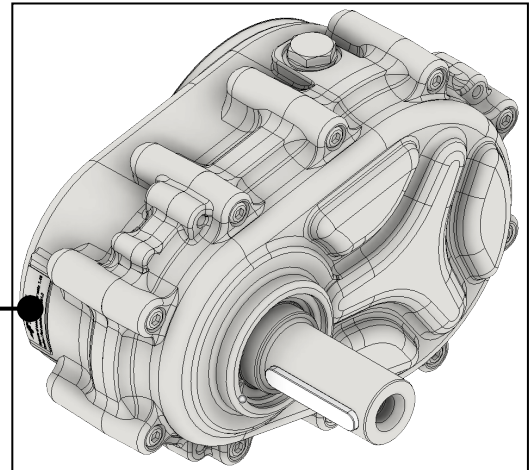

Speed ratio “ τ ” is written on the label attached on crankcase gearbox. It can be:

1. $\tau = 1.48$
2. $\tau = 1.82$
3. $\tau = 2.26$

5.1 Pump speed can be calculated with the following formula:

$$\text{Pump speed} = \text{speed motor} / \tau \quad (\text{ex: } 1820/1.82 = 1000)$$

5.2 Pump speed must not exceed 1000 rpm.

6. DIMENSIONS AND POSITIONS

Dimensions are the same for all three types of gear ratio:

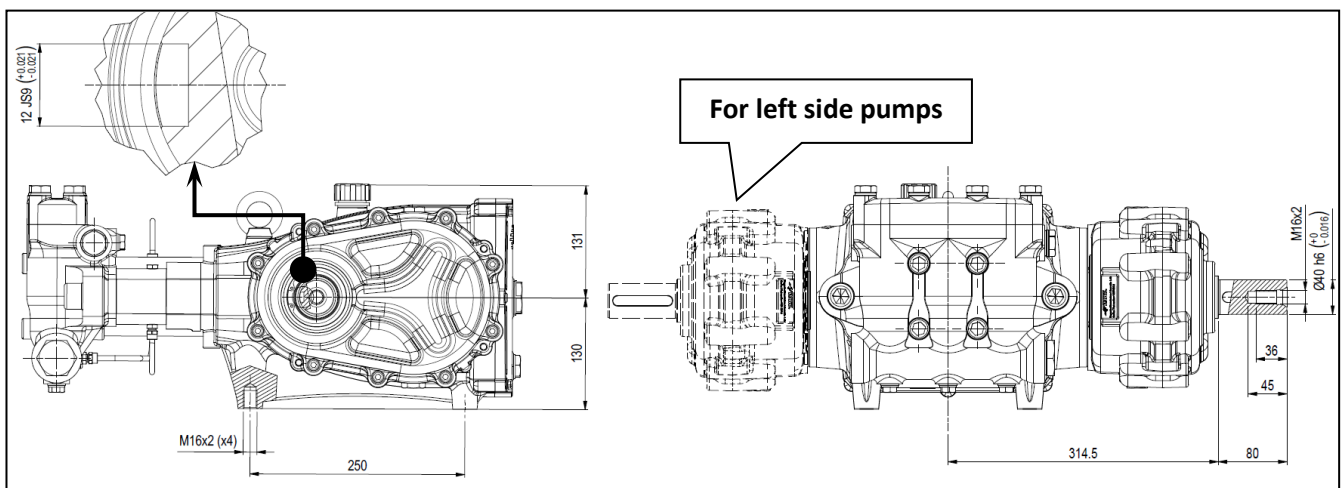

Dimensions reported in the picture above are in mm.

Weight of the complete gearbox is 17.8 kg (without oil).

6.1 Positions

Possible configurations are shown in the picture below.

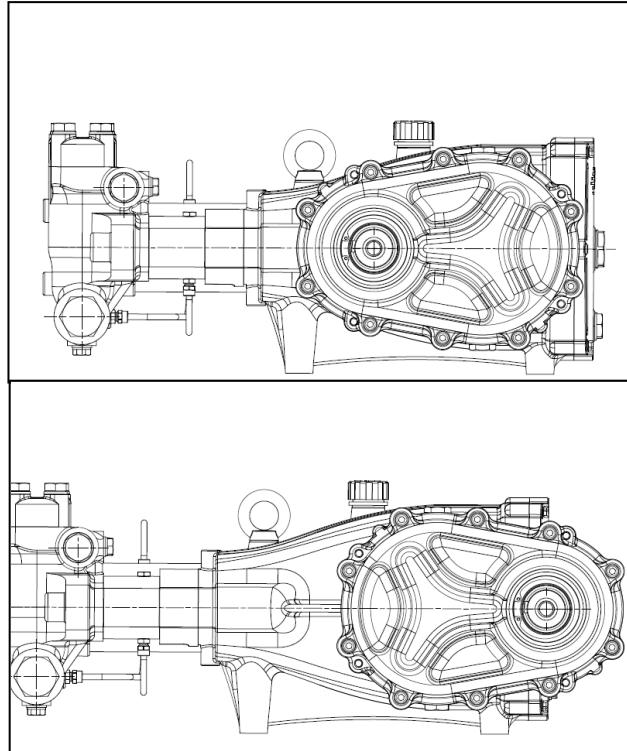

7. NECESSARY TOOLS

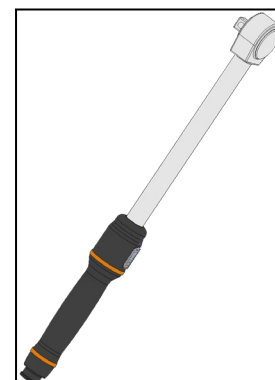
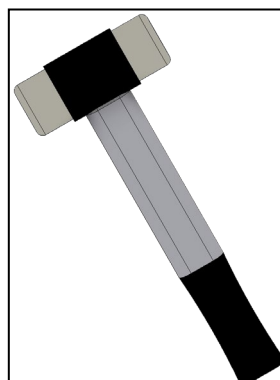
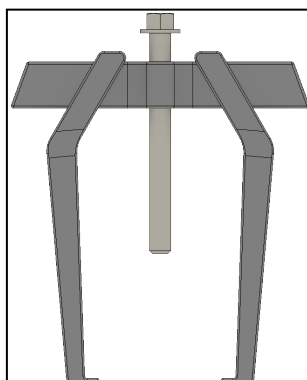
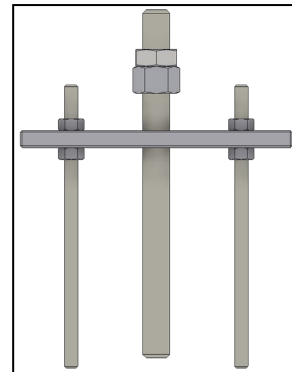
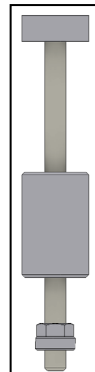

8. 8. INSTALLATION AND ASSEMBLY

Before proceeding with the installation, please read this section carefully.



Incorrect installation of the pumping system can lead to personal injury and property damage: it is important to follow all the points listed below.

8.1 Assembly instructions

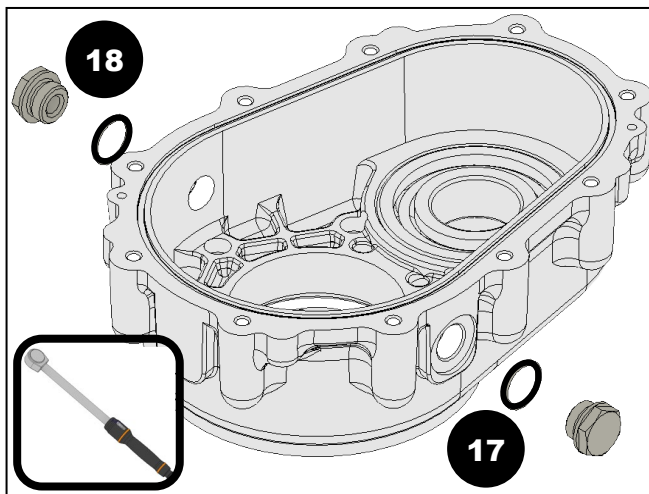

8.1.a Mount the hexagonal plugs (n°18) with O-Rings (n°17).

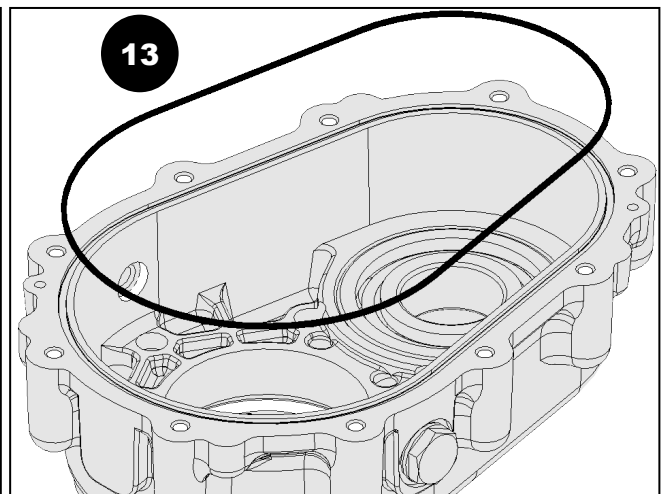

8.1.b Insert O-ring (n°13) into the groove.

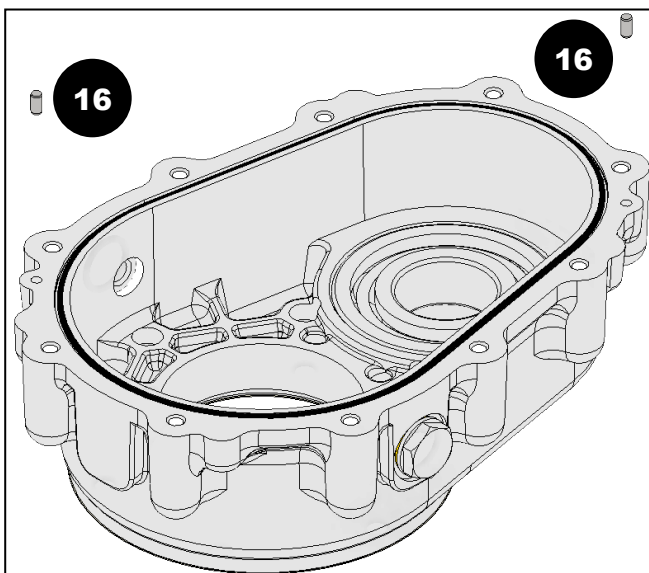

8.1.c Insert the two centring pins (n°16) into the proper holes.

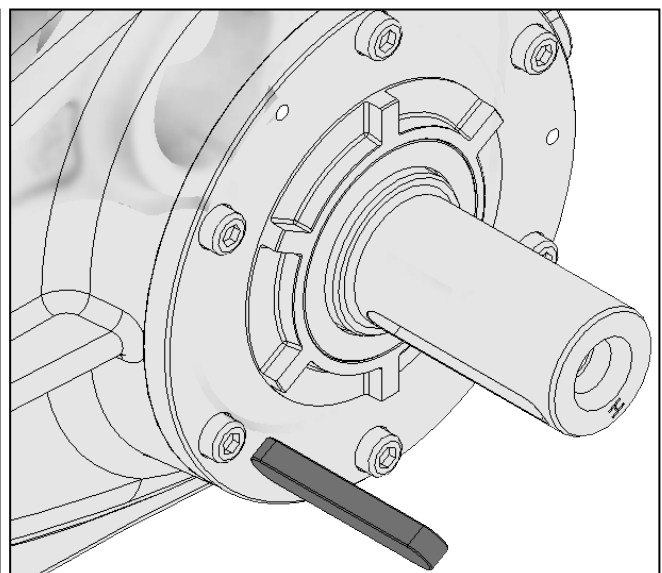

8.1.d Remove the key from the crankshaft of the pump

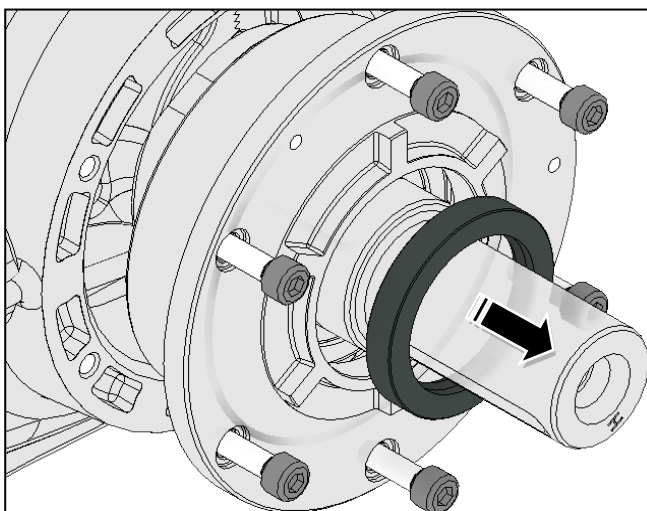

8.1.e Remove the oil seals from the pump shaft.

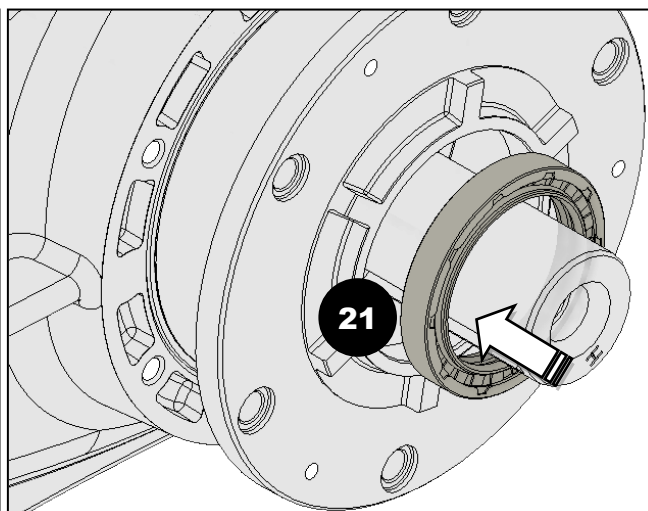

8.1.f Insert new double lips oil seal (n°21) oriented as shown in the picture below, and press on the outer metal ring.

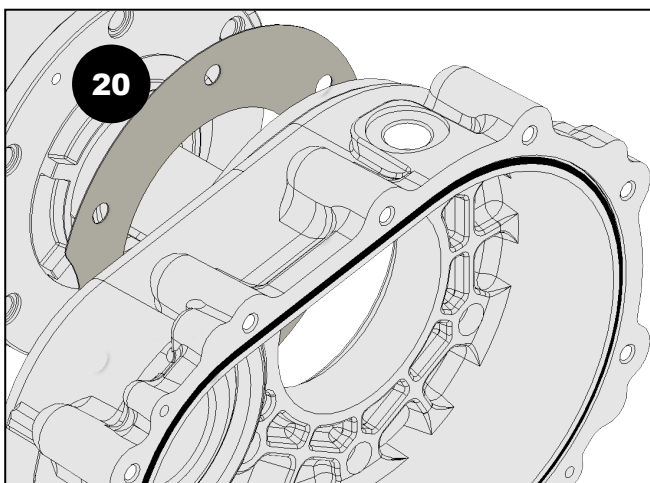

8.1.g Install the paper seal (n°20) between the pump and the gear housing.

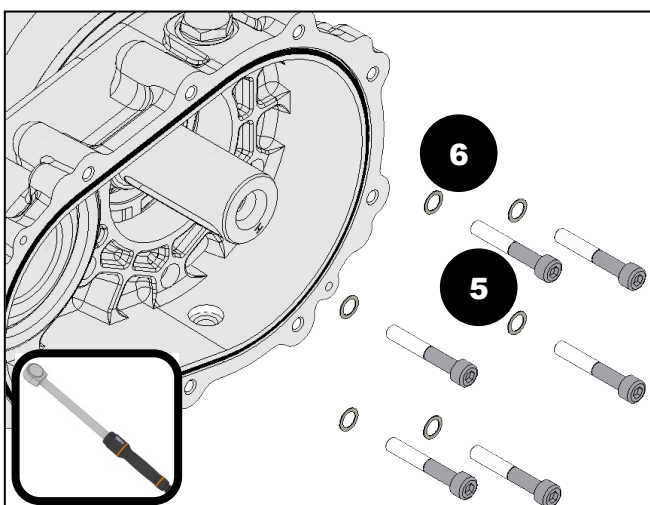
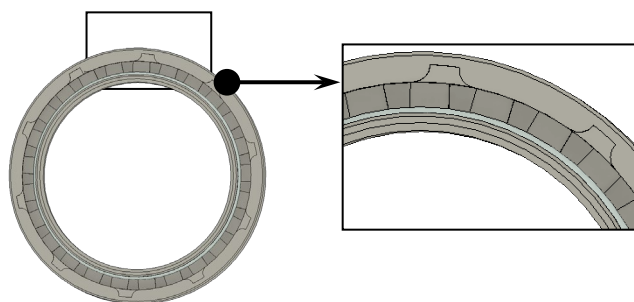

8.1.h Fix the gear housing with 6 screws (n°5) and copper washers (n°6) tightened with 40 Nm of torque.

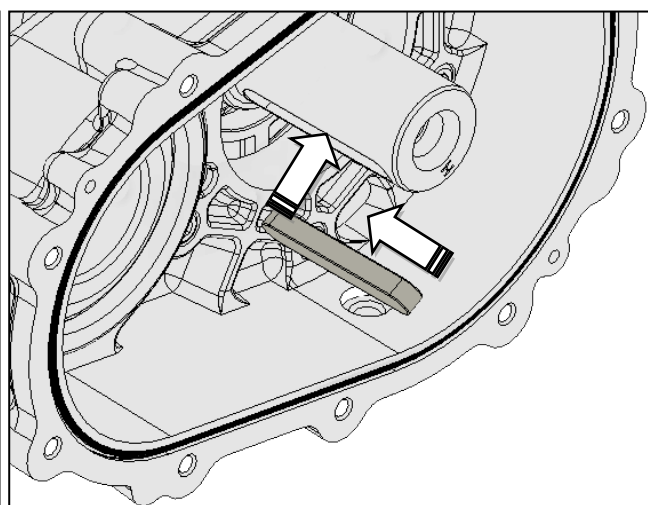

8.1.i Insert the key into the pump crankshaft.

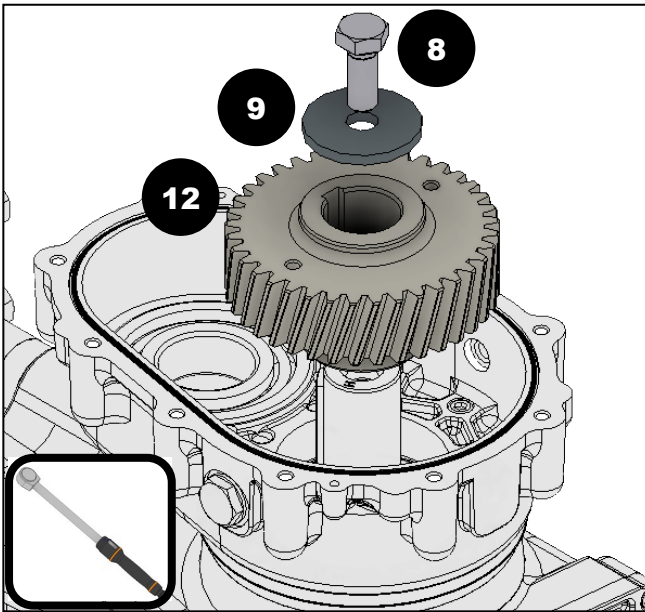

8.1.l Mount the crown (n°12) with the washer (n°9) and screw (n°8) tightened with 70 Nm of torque.

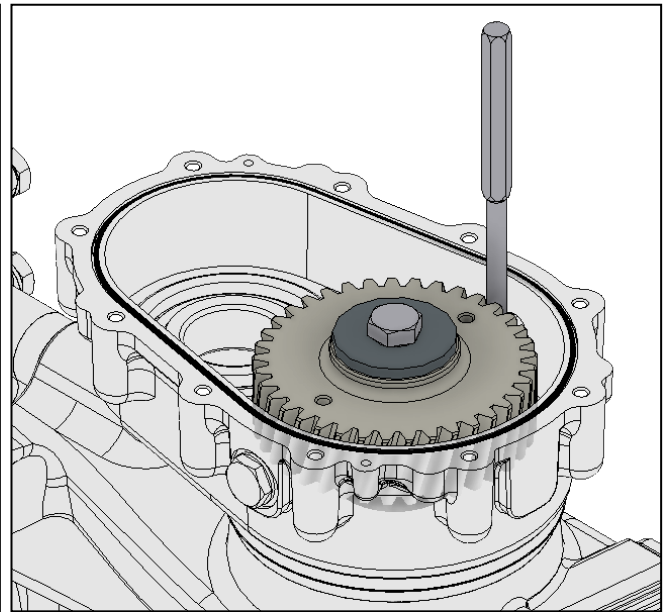

8.1.m Block the gear and tighten the screw with 70 Nm of torque.

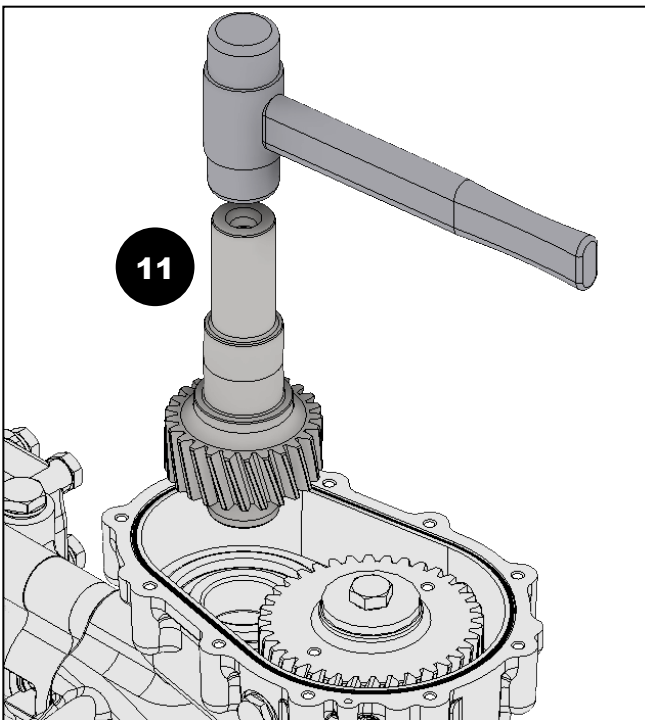

8.1.n Press the pinion (n°11) down with an hammer until it stops.

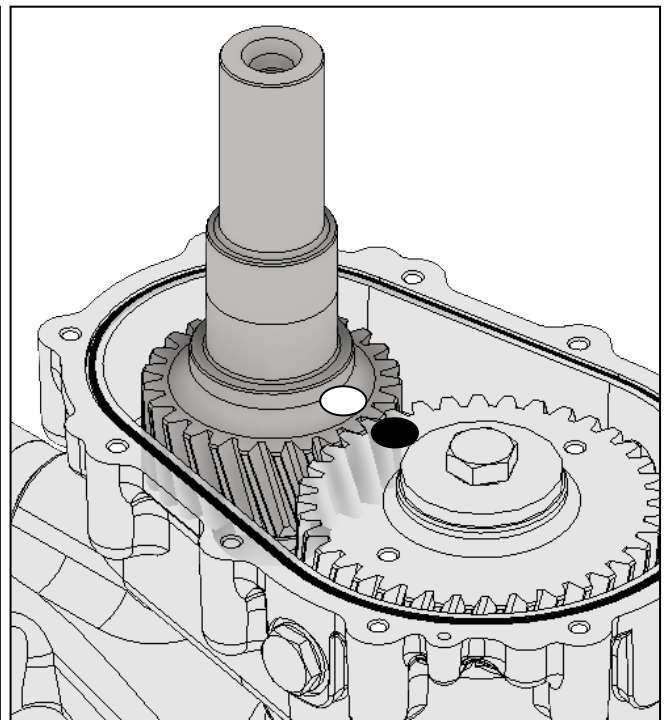

8.1.o Make sure that surface of pinion and crown shown in the picture above are coplanar .

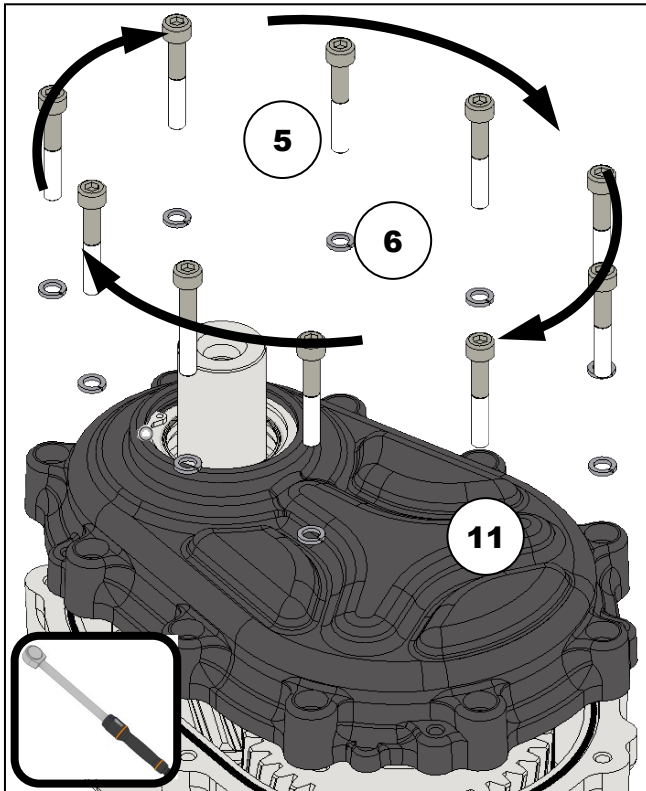

8.1.p Mount 10 fixing screws (n°5) with washer (n°6). Tighten with 40 Nm of torque.

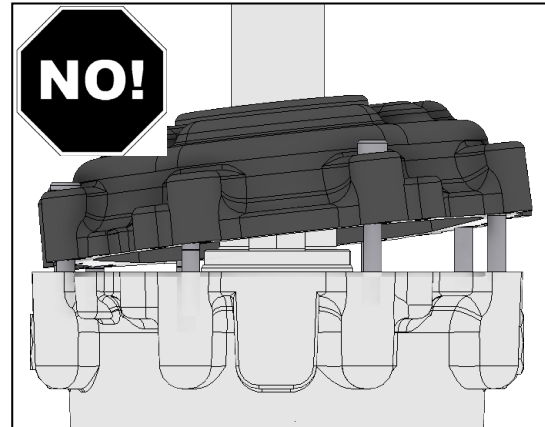
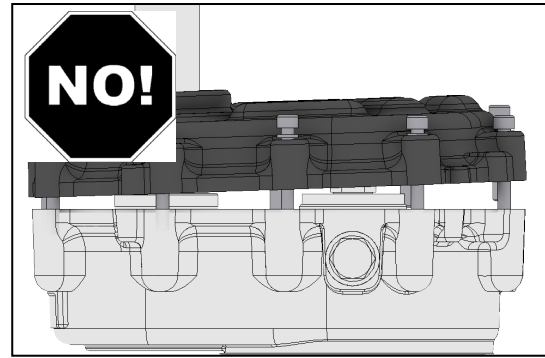

Tighten the screws in the direction indicated in the left side above, maintaining the cover parallel to the gear housing. Avoid the misalignments shown in the pictures above. When the cover come in contact with gear housing, tighten the screws with 40 Nm of torque.

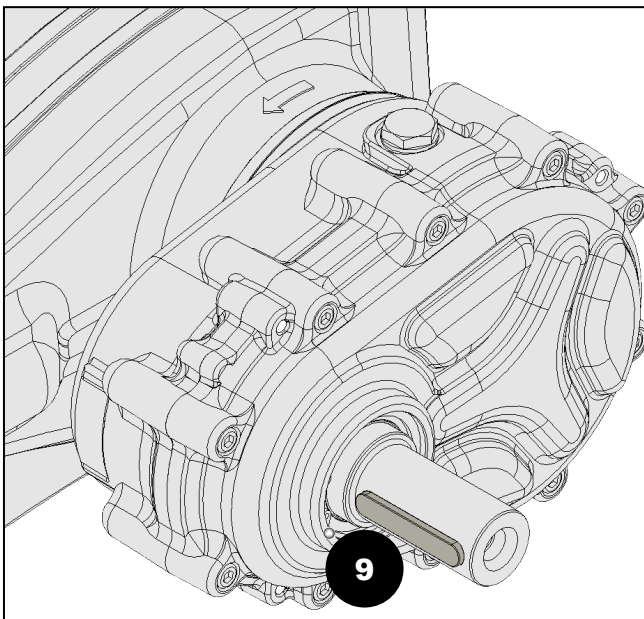

8.1.q Insert the key (n°9).

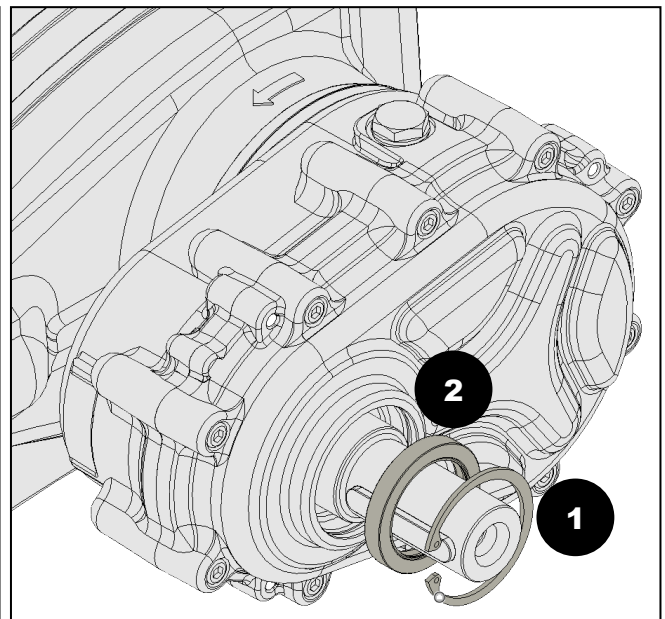

8.1.r Insert oil seal (n°2) and the snap ring (n°1)

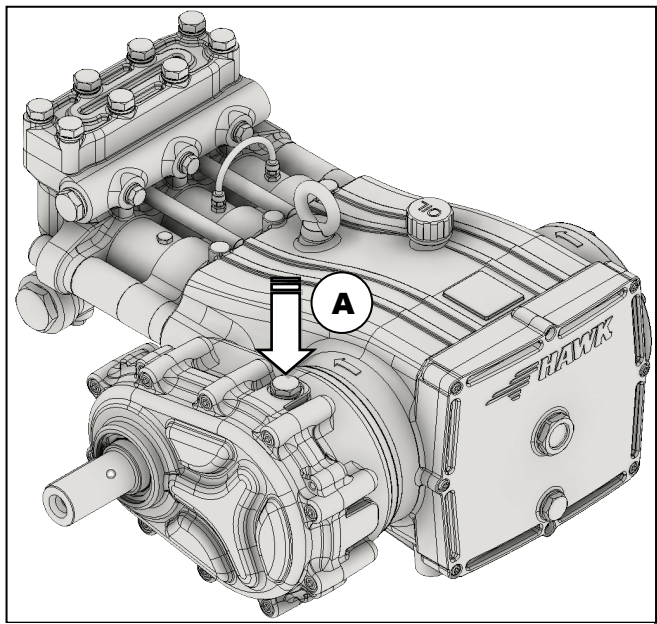
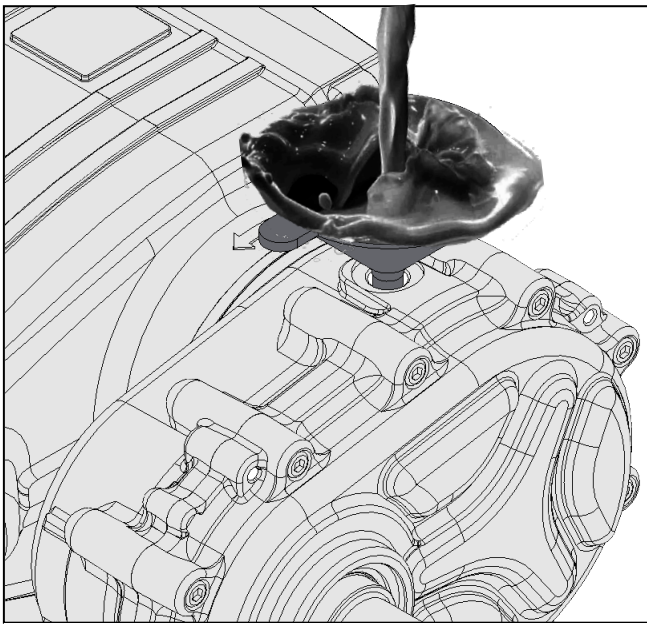

8.1.s Fill the gear box with 0.9 l of oil . Use oil type 80W90. The oil filling plug is marked with "A" in the picture above.

8.2 Removal of mechanical parts

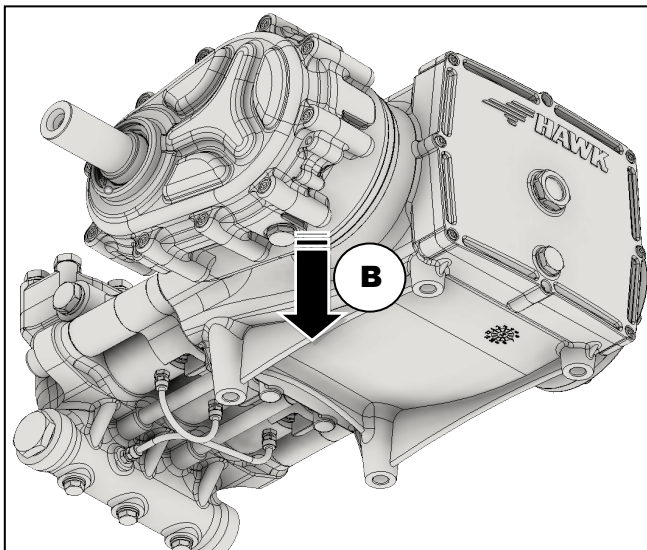

8.2.a Remove all the oil inside the gearbox through the drain plug "B".

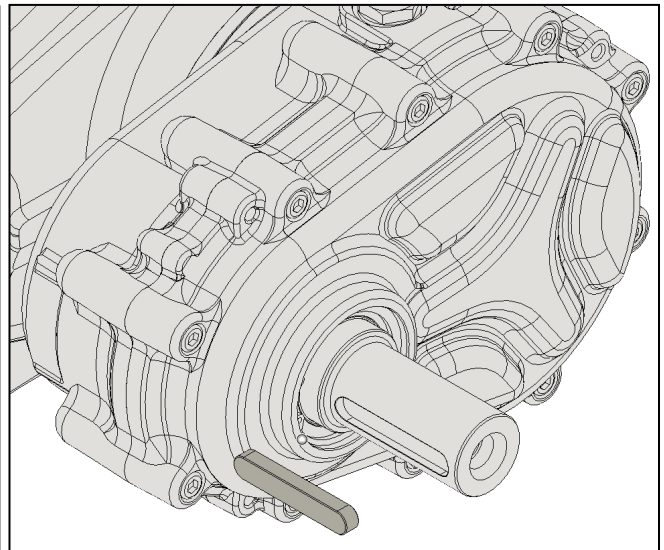

8.2.b Remove the key from the pinion.

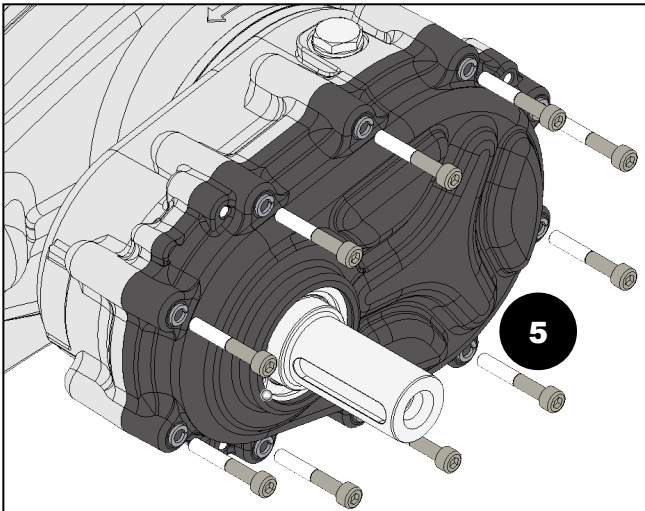

8.2.c Remove the 10 cover fixing screws (n°5)..

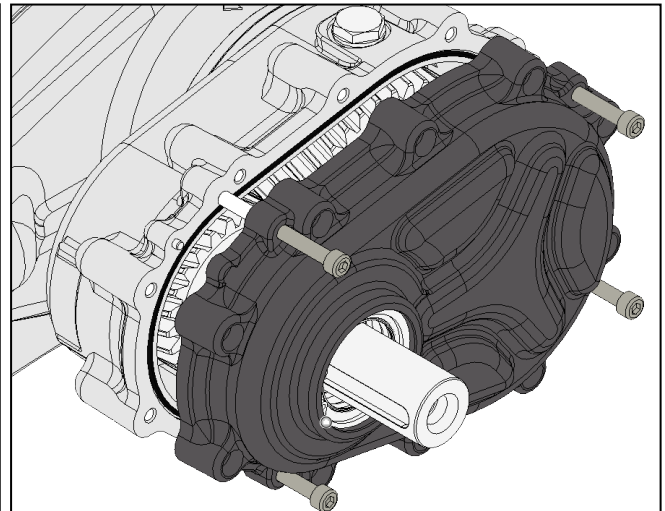

8.2.d Tighten M8 screws in the 4 threaded holes in order to remove the cover.

Depending on user's preferences, it' possible to:

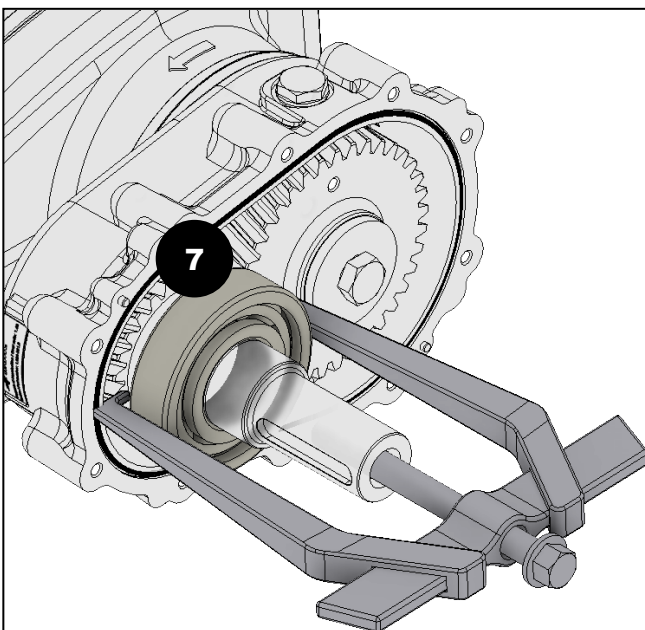

8.2.e.1 extract bearing (n°7) with appropriate tools

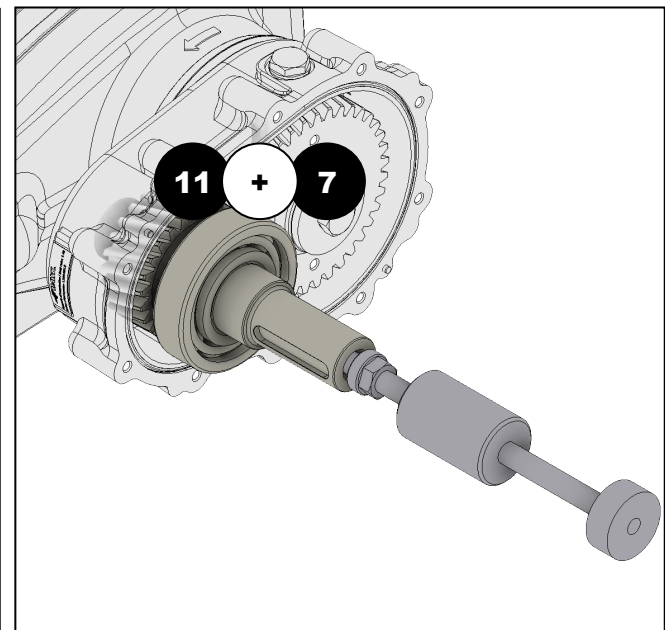

8.2.e.2 extract the assembly bearing (n°7) + pinion (n°11)

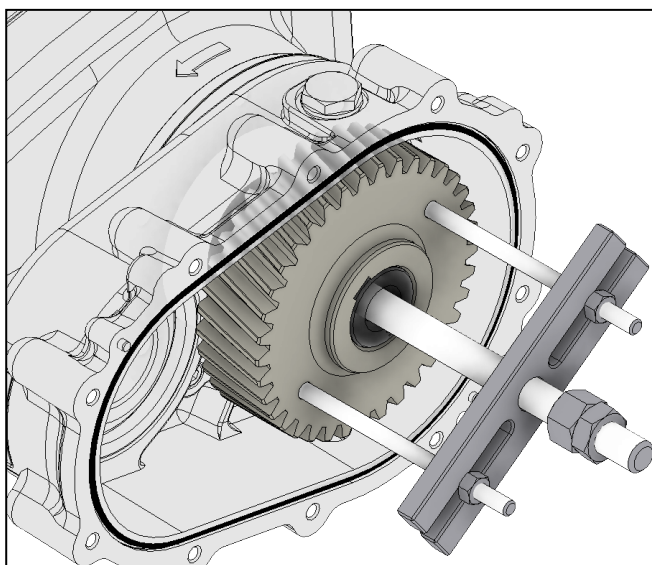

8.2.d Use two M8 threaded holes to extract the gear (n°12).

9. REGULAR MAINTAINANCE

The gearbox's efficiency can be safeguarded by following the regular maintenance schedule below:

CONTROL	DAILY	WEEKLY	800 H	1500 H
OIL LEAKS	X			
HYDRAULIC SYSTEM		X		
OIL CHANGE			X	
REPLACE OF THE PINION OIL SEAL			X	
REPLACE OF THE PUMP OIL SEAL				X



Maintenance work may only be carried out by authorised, qualified personnel and must be noted in the special log.



Always comply with the safety instructions in pump and gearbox manual.