

NMT HY 2022

Albero cavo/scanalato SAEJ744 –
Hollow shaft SAEJ744

Caratteristiche Tecniche

Technical Characteristics

Pump Pompa	Pressure Pressione		Volume Portata				RPM giri/min		Power Potenza			
			l/min		GPM				HP		kW	
	bar	PSI	50 Hz	60 Hz	50 Hz	60 Hz	50 Hz	60 Hz	50 Hz	60 Hz	50 Hz	60 Hz
NMT2120HY	200	2900	21	25	5.5	6.6	1450	1740	10.7	12.8	7.9	9.4

Dimensioni d'ingombro

Overall dimensions

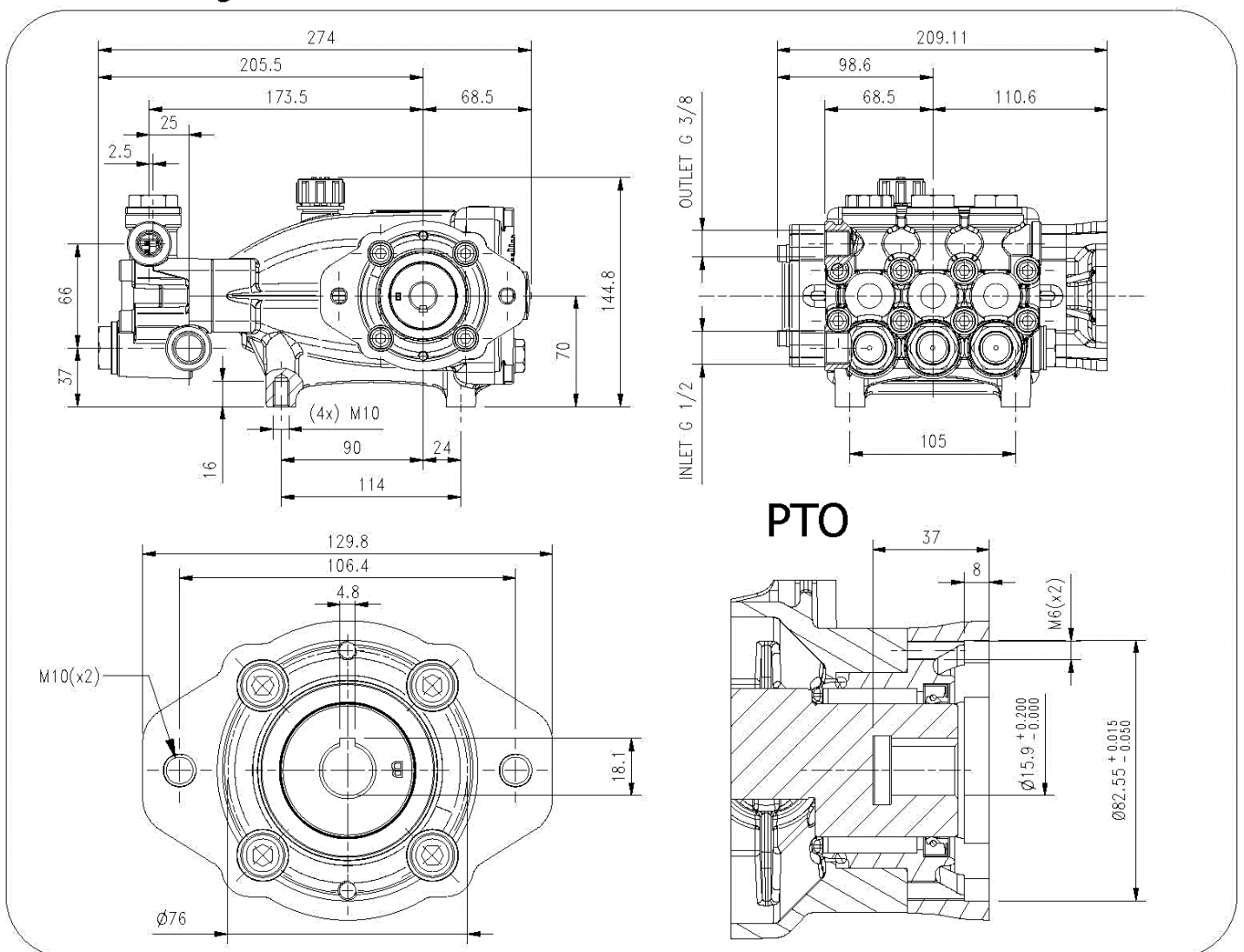

Lubrificazione: Olio SAE 10W40
Capacità: 1.2 Litri
Peso pompa: 18.6 kg

Lubrication: SAE 10W40 Oil
Capacity: 1.2 Litres
Weight: 18.6 kg

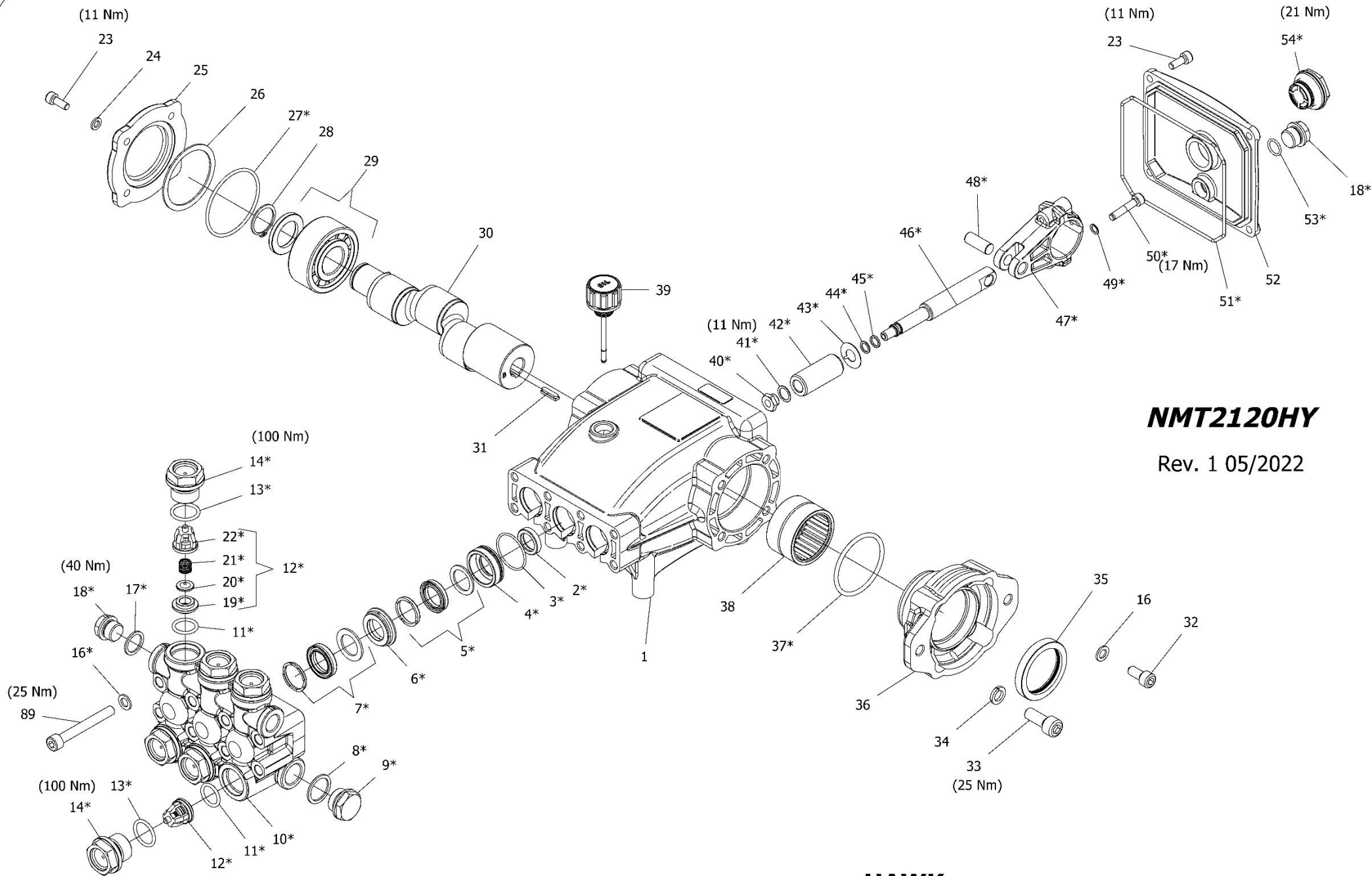

NMT2120HY

Rev. 1 05/2022

HAWK
Pompe NMT HY serie 2022
NMT Pumps 2022 HY series

NMT 2022 HY SERIES

ORDINARY MAINTENANCE KIT / KIT MANUTENZIONE ORDINARIA

KIT	Item Pos.	Part Number Codice	Description	Descrizione	Q.TY by Pump Q.TA per Pompa	NMT2120HYR
A	3- 5- 7	1.099-747.0	PLUNGER SEALS DIA. 20 mm	GUARNIZIONI PISTONE Ø20	1	•
B	11- 12 (19- 20- 21 22) - 13	1.905-543.0	COMPLETE VALVE	VALVOLA COMPLETA	1	

EXTRAORDINARY MAINTENANCE KIT / KIT MANUTENZIONE STRAORDINARIA

KIT	Item Pos.	Part Number Codice	Description	Descrizione	Q.TY by Pump Q.TA per Pompa	NMT2120HYR
C	3- 4- 5- 6- 7	1.905-578.0	COMPLETE SEALS PACKING DIA. 20 mm	PACCO COMPLETO GUARNIZIONI PISTONE Ø20	1	•
D	40- 41- 42 43- 44- 45	1.099-749.0	PLUNGER DIA. 20 mm	PISTONE Ø20	3	
E	2	1.099-751.0	PLUNGER OIL SEALS	ANELLI TENUTA OLIO ASTA	1	
F	18- 27- 37 - 35 - 53 - 54	1.905-654.0	KIT CRANKCASE SEALS	KIT TENUTE CARTER	1	
G	3- 4- 5- 6- 7 8- 9- 10- 11 - 12 (19- 20 21- 22) - 13- 14 - 15 - 16 - 17 - 18	1.099-752.0	COMPLETE MANIFOLD	TESTATA COMPLETA	1	
H	40- 41 42- 45 - 46 - 47 - 48 - 49 - 50	1.905-544.0	CONNECTING ROD PLUNGER ROD ASSY	PREMONTATO ASTA-BIELLA PISTONE	3	
I	13- 14	1.904-251.0	VALVE PLUG ASSY	PREMONTATO TAPPO VAM	6	

“Q.TY by Pump” => Necessary quantity to repair one pump
 “Q.TA’ per Pompa” => Quantità necessaria per riparare una pompa

OPTIONAL

Item Pos.	Part Number Codice	Description	Descrizione	Q.TY by Pump Q.TÀ per Pompa	NMT2120HYR
52	9.853-426.0	THREADED BRASS PLUG G1/4	PREMONTATO TAPPO FORATO	1	•

TOOL KIT

Part Number Codice	Description	Descrizione	Q.TY by Pump Q.TÀ per Pompa	NMT2120HYR
1.099-667.0	TOOL-KIT	TOOL-KIT	1	•
1.904-414.0	OIL SEAL EXTRACTOR TOOL-KIT	TOOL-KIT ESTRAZIONE PARAOLIO	1	

IMPORTANT

IMPORTANTE

* **Part available ONLY in kit**
Disponibile SOLO in kit

(...) **Parts pre-assembled**
Parti pre-assemblate

PARTS LIST LISTA PARTI

Item Pos	Part Number Codice	Description	Descrizione	KIT	Q.TY Q.TÀ	NMT2120HYR
1	9.850-376.0	CRANKCASE	CARTER		1	
2*		PLUNGER OIL SEAL	ANELLO RADIALE	E	3	
3*		"O" RING Ø1.78X31.47	"O" RING Ø1.78X31.47	A-C-G	3	
4*		PRESSURE RING 20MM	PRESSORE "U" Ø20	C-G	3	
5*		LOW PRESSURE W2 Ø20x28x8	ANELLO TENUTA W2 Ø20x28x8	A-C-G	3	
6*		INTERMED. RING 20MM	DIFFUSORE INTER. Ø20	C-G	3	
7*		HIGH PRESSURE W1 Ø20x30x9	ANELLO TENUTA W1 Ø20x30x9	A-C-G	3	
8*		COPPER WASHER G1/2	GUARNIZIONE RAME	G	1	
9*		PLUG G1/2	TAPPO G1/2	G	1	
10*		MANIFOLD HOUSING	TESTATA	G	1	
11*		"O" RING Ø2.62X17.13	"O" RING Ø2.62X17.13	B-G	6	
12*		VALVE ASSEMBLY	VALVOLA PREMONTATA	B-G	6	
13*		"O" RING Ø2.62X20.29	"O" RING Ø2.62X20.29	B-G-I	6	
14*		VALVE PLUG	TAPPO VALVOLA	G-I	6	
15*		MANIFOLD STUD BOLT M8X65 8.8	VITE M8X65 8.8 ZINCATA	G	8	
16*		WASHER Ø8,5	ROSETTA Ø8,5	G	12	
17*		COPPER WASHER G3/8	GUARNIZIONE RAME	G	1	
18*		PLUG G3/8	TAPPO G3/8	G-F	2	
19*		VALVE SEAT	SEDE VALVOLA	B-G	6	
20*		VALVE PLATE	PIATTELLO VALVOLA	B-G	6	
21*		VALVE SPRING	MOLLA VALVOLA	B-G	6	
22*		VALVE CAGE	GABBIA VALVOLA	B-G	6	
23	9.851-474.0	SCREW M6X16	VITE TCEI M6x16 8.8 ZINC.BIA.		8	
24	9.851-115.0	WASHER Ø6,4/12,5x1,6	ROSETTA Ø6,4/12,5x1,6 ZINCATA		4	
25*	9.850-622.0	CLOSED BEARING FLANGE	FLANGIA CHIUSA		1	
26	9.853-996.0	BEARING SPACER	DISTANZIALE CUSCINETTO		1	
27		"O" RING Ø2.62X61.6	"O" RING Ø2.62X61.6	F	1	
28	9.851-198.0	SEEGER RING Ø25 UNI7435	SEEGER ALBERO Ø25 UNI7435		1	
29	9.853-993.0	ROLLER BEARING	CUSCINETTO A RULLI CILINDRICI		1	
30	9.853-977.0	HOLLOW SHAFT 5/8"	ALBERO CAVO 5/8"		1	
31	9.850-451.0	SHAFT KEY	CHIAVETTA A GRADINO 4-4.8x18		1	
32	9.851-478.0	SCREW M8x18	VITE TCEI M8x18 8.8		4	
33	9.851-493.0	SCREW M10X25	VITE TCEI M10x25 ISO4762 12.9	F	2	
34	9.851-154.0	WASHER M10	ROSETTA ELASTICA M10 DIN7980		2	
35*		CRANCKSHAFT SEAL	ANELLO RADIALE Ø42x55x8		1	
36	9.853-976.0	FLANGESAE J744 B	FLANGIA SAE J744 B (NPM - NMT)		1	
37	9.850-714.0	O-RING 159 - Ø3,53x55,56 NBR 70	O-RING 159 - Ø3,53x55,56 NBR 70		1	

Item Pos	Part Number Codice	Description	Descrizione	KIT	Q.TY Q.TÀ	NMT2120HYR
38*	9.850-351.0	ROLLER BEAEING	CUSC. RUL. SENZA ANELLO NK 42/30		1	
39*	9.851-286.0	OIL DISPSTICK	TAPPO SFIATO OLIO GIALLO		1	
40*		PLUNGER NUT	DADO PISTONE	D-H	3	
41*		COPPER SPACER Ø 11.2/15X0.5	ROSETTA RAME Ø 1.2/15X0.5	D-H	3	
42*		PLUNGER 20MM	PISTONE Ø20	D	3	
43*		COPPER SPACER Ø 11.3/24X0.5	ROSETTA RAME Ø 1.3/24X0.5	D	3	
44*		"O" RING Ø1.78X7.66	"O" RING Ø1.78X7.66	D-H	3	
45*		TEFLON RING	ANELLO ANTIESTRUSIONE	D-H	3	
46		PLUNGER ROD	ASTA PISTONE	H	3	
47*		CONNECTING ROD	BIELLA	H	3	
48*		CONNECTING ROD PIN	SPINOTTO	H	3	
49		SPRING WASHER Ø6	ROSETTA ELASTICA Ø6	H	6	
50		CONNECTING ROD SCREW M6X30	VITE M6X30	H	6	
51		"O" RING Ø 2.62X126.67	"O" RING Ø 2.62X126.67	F	1	
52	9.850-388.0	CRANKCASE COVER	COPERCHIO POSTERIORE		1	
53		"O" RING Ø1.78X14	"O" RING Ø1.78X14	F	1	
54		SIGHT GLASS, G3/4	SPIA LIVELLO OLIO G3/4	F	1	