

Pump Pompa	Pressure Pressione		Volume Portata				RPM giri/min		Power Potenza			
			l/min		GPM				HP		kW	
	bar	PSI	50 Hz	60 Hz	50 Hz	60 Hz	50 Hz	60 Hz	50 Hz	60 Hz	50 Hz	60 Hz
NLT2525S	250	3650	25	30	6.6	7.9	1000	1200	16.0	19.2	11.8	14.2
NLT2525	250	3650	25	30	6.6	7.9	1450	1740	16.1	19.3	11.9	14.3

NLT2525IS	250	3650	25	30	6.6	7.9	1000	1200	16.0	19.2	11.8	14.2
NLT1725I	250	3650	17	20	4.5	5.4	1450	1740	11.0	13.2	8.1	9.7
NLT2125I	250	3650	21	25	5.6	6.7	1450	1740	13.5	16.2	9.9	11.9
NLT2525I	250	3650	25	30	6.6	7.9	1450	1740	16.1	19.3	11.9	14.3
NLT3020I	200	2900	30	36	7.9	9.5	1450	1740	15.5	18.6	11.4	13.7

Dimensioni d'ingombro

Overall dimensions

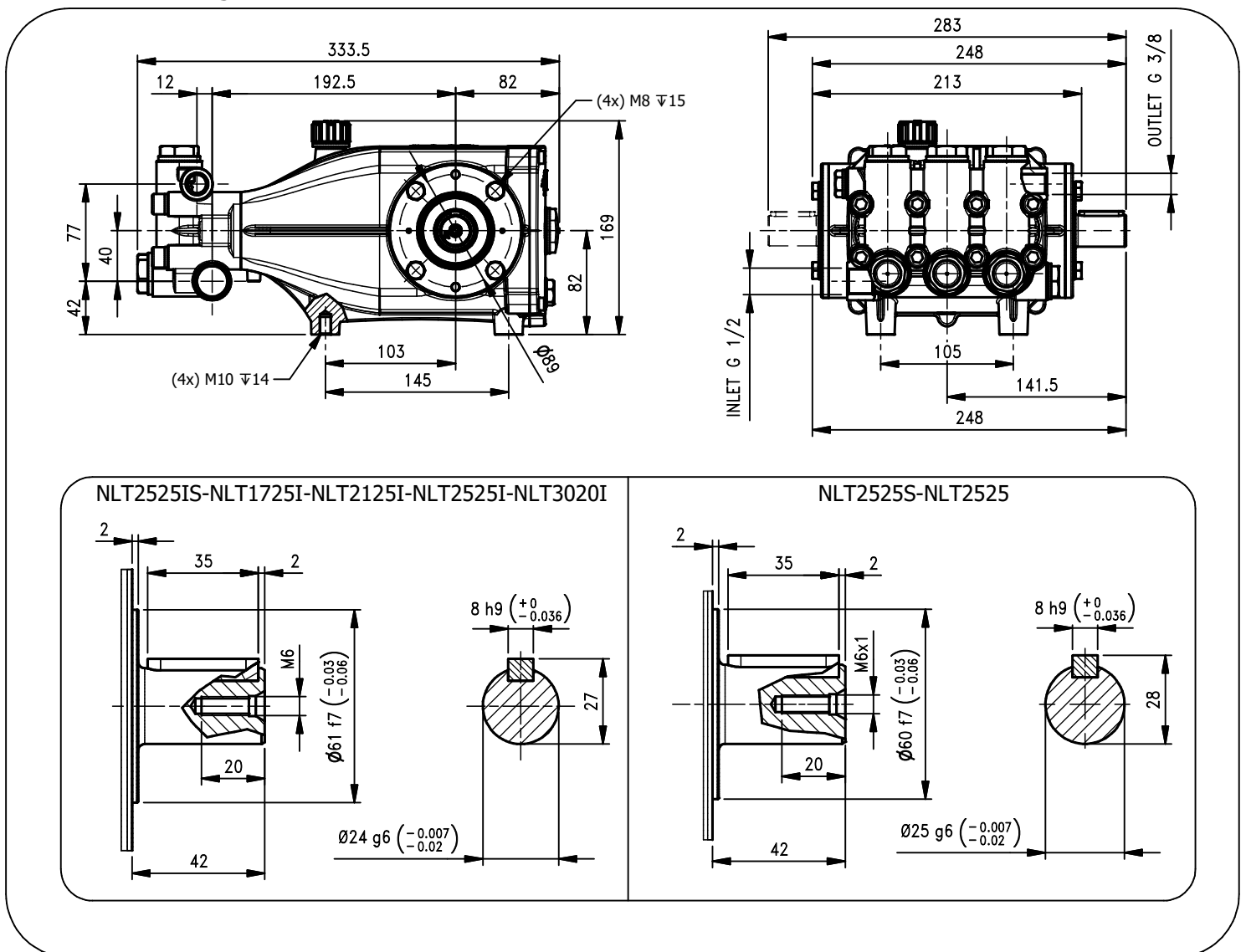

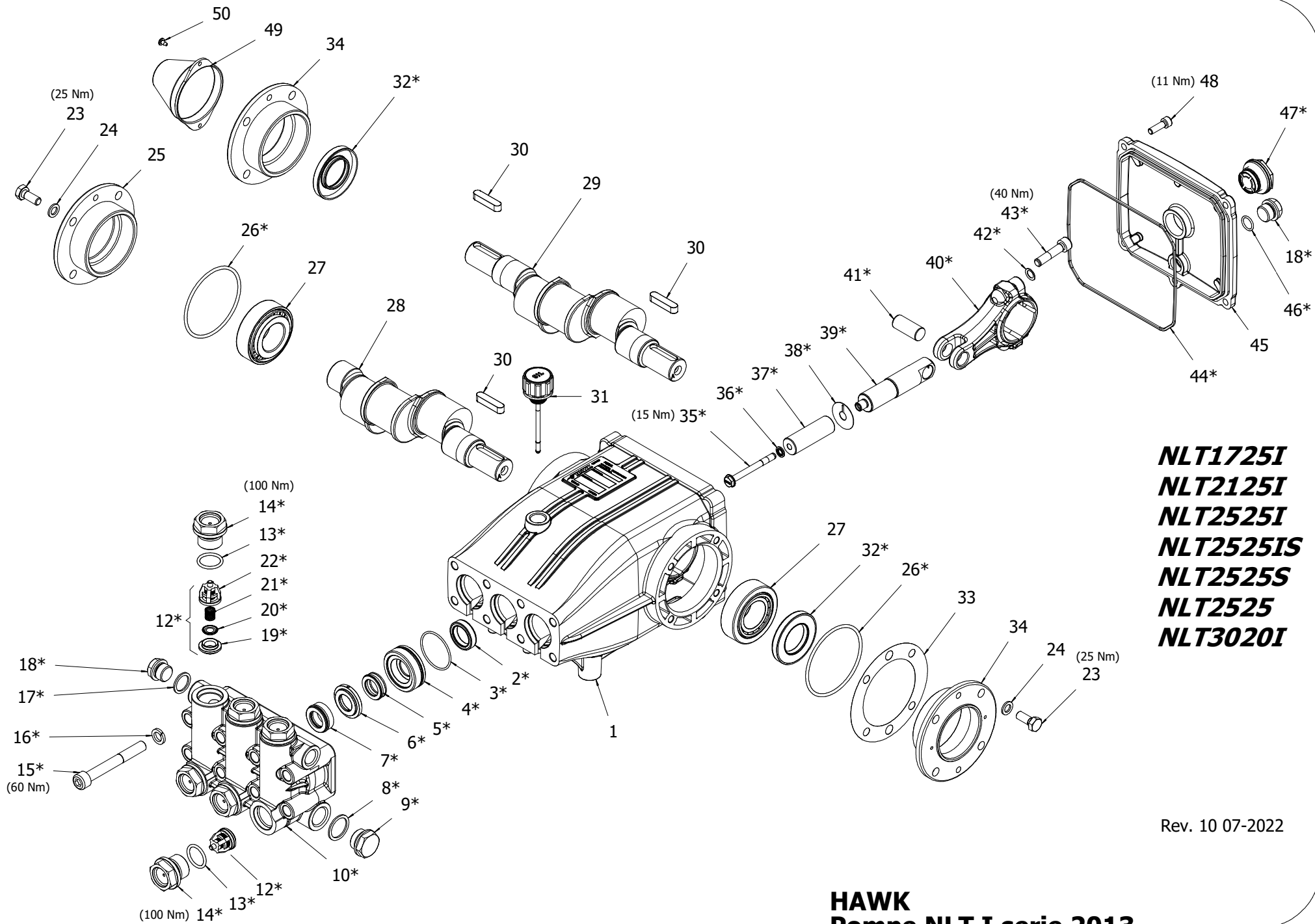

**NLT1725I**  
**NLT2125I**  
**NLT2525I**  
**NLT2525IS**  
**NLT2525S**  
**NLT2525**  
**NLT3020I**

Rev. 10 07-2022

**HAWK**  
**Pompe NLT I serie 2013**  
**NLT I pumps 2013 series**

# NLT - NLTI

Caratteristiche Tecniche

Albero maschio – Solid Shaft

Technical Characteristics

Pump Pompa	Pressure Pressione		Volume Portata				RPM giri/min		Power Potenza			
			l/min		GPM				HP		kW	
	bar	PSI	50 Hz	60 Hz	50 Hz	60 Hz	50 Hz	60 Hz	50 Hz	60 Hz	50 Hz	60 Hz
NLT2525S	250	3625	25	30	6.6	7.9	1000	1200	16.0	19.2	11.8	14.2
NLT2525	250	3625	25	30	6.6	7.9	1450	1740	16.0	19.2	11.8	14.2

NLT2525IS	250	3625	25	30	6.6	7.9	1000	1200	16.0	19.2	11.8	14.2
NLT1725I	250	3625	17	20	4.5	5.4	1450	1740	11.0	13.2	8.1	9.7
NLT2125I	250	3625	21	25	5.6	6.7	1450	1740	13.5	16.2	9.9	11.9
NLT2525I	250	3625	25	30	6.6	7.9	1450	1740	16.0	19.2	11.8	14.2
NLT3020I	200	2900	30	36	7.9	9.5	1450	1740	15.5	18.6	11.4	13.7

Dimensioni d'ingombro

Overall dimensions

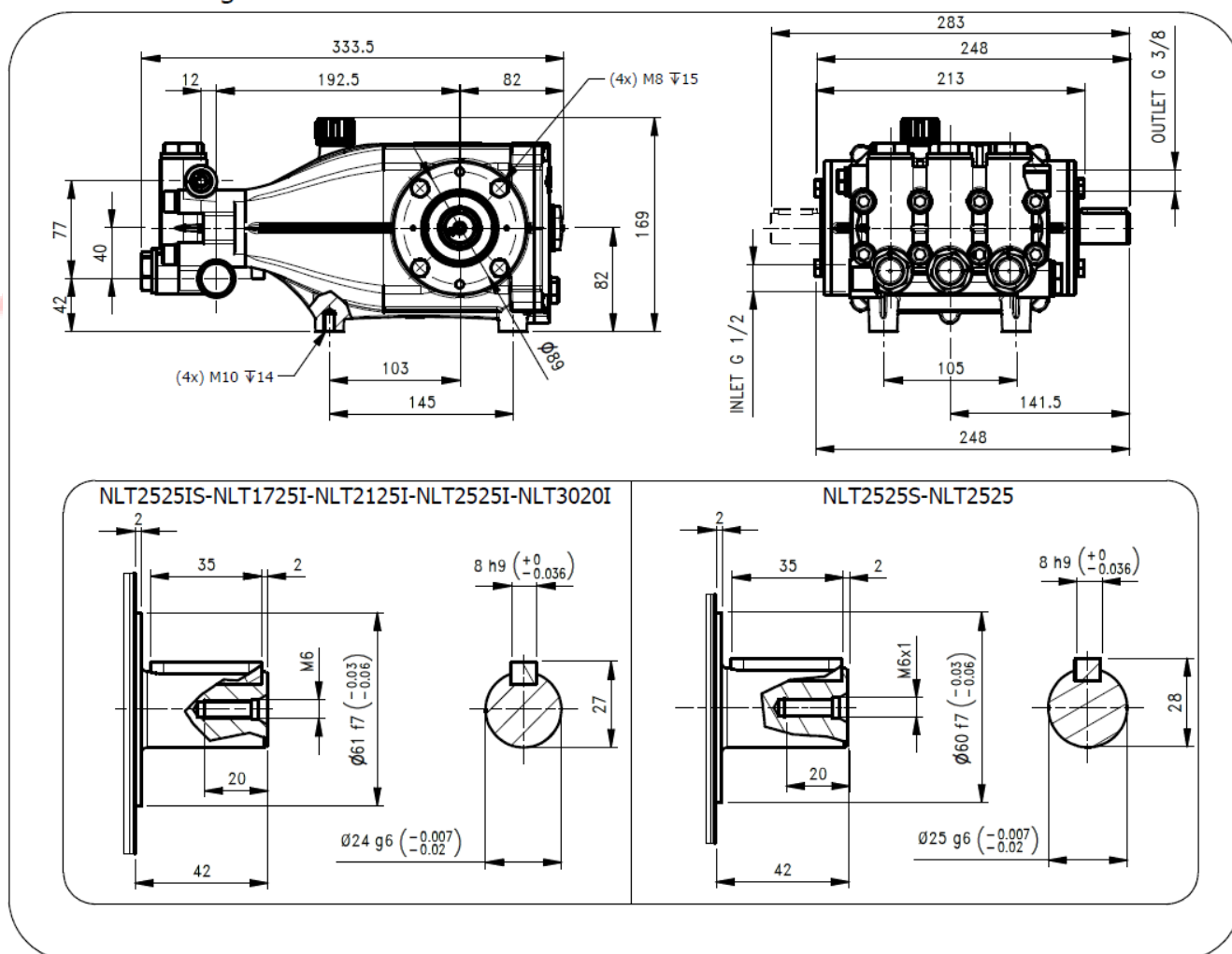

Lubrificazione: Olio SAE 10W40  
 Capacità: 1.2 Litri  
 Peso pompa: 15.2 kg

Lubrication: SAE 10W40 Oil  
 Capacity: 1.2 Litres  
 Weight: 15.2 kg



## NLT 2013 SERIES

### ORDINARY MAINTENANCE KIT / KIT MANUTENZIONE ORDINARIA

KIT	Item - Pos	Part Number - Codice	Description	Descrizione	Q.TY per pump - Q.TÀ per pompa	NLT2525ISR/L	NLT1725IR/L	NLT2125IR/L	NLT2525IR/L	NLT3020IR/L	NLT2525SR/L	NLT2525ISB	NLT2525IB	NLT3020IB	NLT2525SB	NLT2525B	
A	3- 5- 7	1.099-759.0	PLUNGER SEALS DIA. 20 mm	GUARNIZIONI PISTONE Ø20	1	•				•	•	•		•	•		
		1.099-760.0	PLUNGER SEALS DIA. 18 mm	GUARNIZIONI PISTONE Ø18			•	•	•					•			
B	11- 12- 13 (19- 20- 21 22)	1.905-669.0	COMPLETE VALVE	VALVOLA COMPLETA	1	•	•	•	•	•	•	•	•	•	•	•	•

### EXTRAORDINARY MAINTENANCE KIT / KIT MANUTENZIONE STRAORDINARIA

KIT	Item - Pos	Part Number - Codice	Description	Descrizione	Q.TY per pump - Q.TÀ per pompa	NLT2525SR/L	NLT1725IR/L	NLT2125IR/L	NLT2525IR/L	NLT3020IR/L	NLT2525SR/L	NLT2525ISB	NLT2525IB	NLT3020IB	NLT2525SB	NLT2525B	
C	3- 4- 5- 6 7	1.905-670.0	COMPLETE SEALS PACKING DIA. 20 mm	PACCO COMPLETO GUARNIZIONI PISTONE Ø20	1	•				•	•	•		•	•		
		1.905-671.0	COMPLETE SEALS PACKING DIA. 18 mm	PACCO COMPLETO GUARNIZIONI PISTONE Ø18				•	•	•					•		
D	35- 36- 37 38	1.099-763.0	PLUNGER DIA. 20 mm	PISTONE Ø20	3	•				•	•	•		•	•		
		1.099-764.0	PLUNGER DIA. 18 mm	PISTONE Ø18				•	•	•					•		
E	2	1.099-766.0	PLUNGER OIL SEALS	ANELLI TENUTA OLIO ASTA	1	•	•	•	•	•	•	•	•	•	•	•	•
F	18- 26- 32 44- 46- 47	1.905-613.0	KIT CRANKCASE SEALS	KIT TENUTE CARTER	1	•	•	•	•	•	•	•	•	•	•	•	•
G	3- 4- 5- 6 7- 8- 9- 10 11- 12- 13 14-15- 16 17- 18	1.099-767.0	COMPLETE MANIFOLD DIA. 20 mm	TESTATA COMPLETA Ø20	1	•				•	•	•		•	•		
		1.099-768.0	COMPLETE MANIFOLD DIA. 18 mm	TESTATA COMPLETA Ø18				•	•	•					•		
H	39- 40- 41 42- 43	1.904-182.0	CONNECTING ROD PLUNGER ROD ASSY	PREMONTATO ASTA-BIELLA PISTONE	3	•	•	•	•	•	•	•	•	•	•	•	•
I	13- 14	1.904-251.0	VALVE PLUG ASSY	PREMONTATO TAPPO VAM	6	•	•	•	•	•	•	•	•	•	•	•	•

“Q.TY by Pump” => Necessary quantity to repair one pump  
 “Q.TA’ per Pompa” => Quantità necessaria per riparare una pompa

Part Number - Codice	Description	Descrizione
1.099-665.0	TOOL-KIT	TOOL-KIT
1.905-659.0	SEAL EXTRACTOR TOOL-KIT	TOOL-KIT ESTR. PARAOLIO

**IMPORTANT** **IMPORTANTE**

\* **Part available ONLY in kit**  
**Disponibile SOLO in kit**

(...) **Parts pre-assembled**  
**Parti pre-assemblate**

**PARTS LIST LISTA PARTI**

Item - Pos	Part Number - Codice	Description	Descrizione	KIT	Q.TY per pump - Q.TA per pompa	NLT2525SR/L	NLT1725IR/L	NLT2125IR/L	NLT2525IR/L	NLT3020IR/L	NLT2525SR/L	NLT2525ISB	NLT2525IB	NLT3020IB	NLT2525SB	NLT2525B
1	9.850-377.0	CRANKCASE	CARTER		1											
2*		PLUNGER OIL SEAL	ANELLO RADIALE	E	3	•	•	•	•	•	•	•	•	•	•	•
3*		"O" RING Ø1.78X37.82	"O" RING Ø1.78X37.82	A-C-G	3											
4*		PRESSURE RING 20MM	PRESSORE "U" Ø20	C-G	3	•			•	•	•	•	•	•	•	
		PRESSURE RING 18MM	PRESSORE "U" Ø18			•	•	•					•			
5*		LOW PRESSURE "U" SEAL, DIA.20MM	ANELLO TENUTA "U" Ø20	A-C-G	3	•			•	•	•	•	•	•	•	
		LOW PRESSURE "U" SEAL, DIA.18MM	ANELLO TENUTA "U" Ø18			•	•	•					•			
6*		INTERMED. RING 20MM	DIFFUSORE INTER. Ø20	C-G	3	•			•	•	•	•	•	•	•	
		INTERMED. RING 18MM	DIFFUSORE INTER. Ø18			•	•	•					•			
7*		HIGH PRESSURE "U" SEAL, DIA.20MM	ANELLO TENUTA "U" Ø20	A-C-G	3	•			•	•	•	•	•	•	•	
		HIGH PRESSURE "U" SEAL, DIA.18MM	ANELLO TENUTA "U" Ø18			•	•	•					•			
8*		COPPER WASHER G1/2	GUARNIZIONE RAME	G	1	•	•	•	•	•	•	•	•	•	•	•
9*		PLUG G1/2	TAPPO G1/2	G	1	•	•	•	•	•	•	•	•	•	•	•
10*		MANIFOLD HOUSING DIA.20	TESTATA Ø20	G	1	•			•	•	•	•	•	•	•	
		MANIFOLD HOUSING DIA.18	TESTATA Ø18			•	•	•					•			
11*		"O" RING Ø2.62X17.13	"O" RING Ø2.62X17.13	B-G	6											
12*		VALVE ASSEMBLY	VALVOLA PREMONTATA	B-G	6											
13*		"O" RING Ø2.62X20.24	"O" RING Ø2.62X20.24	B-G-I	6											
14*		VALVE PLUG	TAPPO VALVOLA	G-I	6											
15*		MANIFOLD SCREW M10X80 GEOMET	VITE M10X80 GEOMET	G	8											
16*		WASHER Ø10,2	ROSETTA Ø10,2	G	8											
17*		COPPER WASHER G3/8	GUARNIZIONE RAME	G	1	•	•	•	•	•	•	•	•	•	•	•
18*		PLUG G3/8	TAPPO G3/8	G-F	2											•
19*		VALVE SEAT	SEDE VALVOLA	B-G	6											
20*		VALVE PLATE	PIATTELLO VALVOLA	B-G	6											
21*		VALVE SPRING	MOLLA VALVOLA	B-G	6											
22*		VALVE CAGE	GABBIA VALVOLA	B-G	6											
23	9.851-503.0	HEXAGONAL SCREW M8X20	VITE M8X20		8											
24	9.851-114.0	WASHER	ROSETTA Ø8,5		6											
25	9.850-620.0	CLOSED BEARING HOUSING	FLANGIA CHIUSA		→	1	1	1	1	1	1	0	0	0	0	0

Item - Pos	Part Number - Codice	Description	Descrizione	KIT	Q.TY per pump - Q.TÀ per pompa	NLT2525ISR/L	NLT1725IR/L	NLT2125IR/L	NLT2525IR/L	NLT3020IR/L	NLT2525SR/L	NLT2525ISB	NLT2525IB	NLT3020IB	NLT2525SB	NLT2525B	
26*		"O" RING Ø1.78X71.12	"O" RING Ø1.78X71.12	F	2	•	•	•	•	•	•	•	•	•	•	•	
27	9.850-347.0	ROLLER BEARING	CUSCINETTO A RULLI		2	•	•	•	•	•	•	•	•	•	•	•	
28	9.850-208.0	SINGLE - ENDED SHAFT	ALBERO SEMPLICE P.D.F.		1	•											
	9.850-209.0	" " "	" " "			•											
	9.850-210.0	" " "	" " "					•									
	9.850-211.0	" " "	" " "						•								
	9.850-212.0	" " "	" " "							•							
	9.850-213.0	" " "	" " "								•						
29	9.851-900.0	DOUBLE - ENDED SHAFT	ALBERO DOPPIA P.D.F.		1							•					
	9.850-214.0	" " "	" " "										•				
	9.850-215.0	" " "	" " "											•			
	9.850-216.0	" " "	" " "												•		
	9.850-217.0	" " "	" " "													•	
30	9.850-446.0	CRANKSHAFT KEY	CHIAVETTA		→	1	1	1	1	1	1	2	2	2	2	2	
31	9.851-287.0	OIL DIP STICK	TAPPO LIVELLO OLIO		1	•	•	•	•	•	•	•	•	•	•	•	
32*		CRANKSHAFT SEAL	ANELLO RADIALE	F	→	1	1	1	1	1	1	2	2	2	2	2	
33	9.850-546.0	SHIM	DISTANZIALE		1	•	•	•	•	•	•	•	•	•	•	•	
34	9.850-610.0	BEARING HOUSING I Ø61	FLANGIA I Ø61		→	1	1	1	1	1		2	2	2			
	9.850-619.0	BEARING HOUSING Ø60	FLANGIA Ø60								1					2	2
35*		PLUNGER SCREW	VITE PISTONE	D-H	3	•	•	•	•	•	•	•	•	•	•	•	
36*		BONDED SEAL	BONDED SEAL	D-H	3	•	•	•	•	•	•	•	•	•	•	•	
37*		PLUNGER 20MM	PISTONE Ø20	D	3	•				•	•	•	•	•	•	•	
		PLUNGER 18MM	PISTONE Ø18			•	•	•					•			•	
38*		COPPER SPACER	ROSETTA RAME	D	3												
39*		PLUNGER ROD	ASTA PISTONE	H	3												
40*		CONNECTING ROD	BIELLA	H	3												
41*		CONNECTING ROD PIN	SPINOTTO	H	3												
42*		SPRING WASHER Ø6	ROSETTA ELASTICA Ø6	H	6												
43*		CONNECTING ROD SCREW M8X35	VITE M8X35	H	6	•	•	•	•	•	•	•	•	•	•	•	
44*		"O" RING Ø 2.62X152.07	"O" RING Ø 2.62X152.07	F	1												
45	9.850-389.0	CRANKCASE COVER	COPERCHIO POSTERIORE		1												
46*		"O" RING Ø1.78X14	"O" RING Ø1.78X14	F	1												
47*		SIGHT GLASS, G3/4	SPIA LIVELLO OLIO G3/4	F	1												
48	9.851-474.0	SCREW M6X16	VITE M6X16		5												
49	9.850-442.0	SHAFT PROTECTOR	CAPPELLOTTO PROT.		1							•	•	•	•	•	
50	9.851-528.0	SCREW	VITE CAPPELLOTTO		2												