

RIDUTTORI PER MOTORI A SCOPPIO 13-17,7-23 kW
GEARBOX FOR PETROL ENGINES 13-17.7-23 kW
1.904-903.0 – 1.904-904.0 – 1.904-905.0 – 1.904-906.0

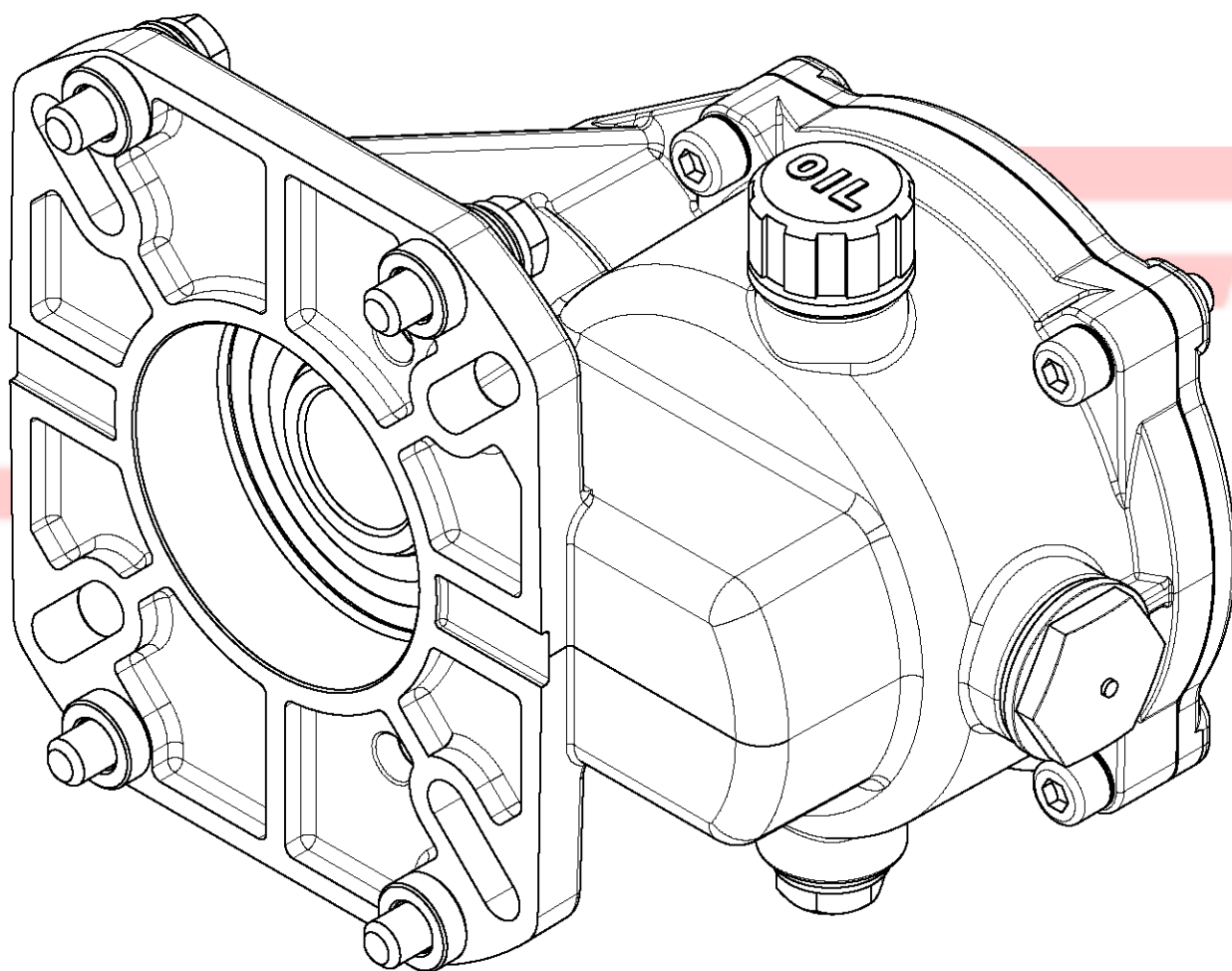

CARATTERISTICHE TECNICHE / SPECIFICATIONS

Codice Riduttore <i>Part Number</i>	1.904-906.0	1.904-905.0	1.904-904.0	1.904-903.0
Potenza max motore <i>Max Engine Power</i>	13 kW (17.7 HP)	17,7 kW (24 HP)	17,7 kW (24 HP)	23 kW (31 HP)
Albero Motore <i>Engine Shaft</i>	25,4 mm (1")	25,4 mm (1")	28,6 mm (1 1/8")	28,6 mm (1 1/8")
Per Pompe Serie <i>For Pump Series</i>	NMT-NPM	NLTI-XLTI PXI-XXT	NLTI-XLTI PXI-XXT	PXI-XXT
Flangia Motore <i>Motor flange</i>	SAE J609b			
Albero Pompa <i>Pump Shaft</i>	24 mm			
Rapporto di riduzione <i>Gear Ratio</i>	2,176:1 (3150 / 1450 rpm)			
Olio Tipo <i>Lubrication Oil</i>	SAE 90			
Capacità Olio <i>Oil Capacity</i>	0,33 l (11 Oz.)			
Peso <i>Weight</i>	4 kg (1,82 lb)			

ROTAZIONE / ROTATION

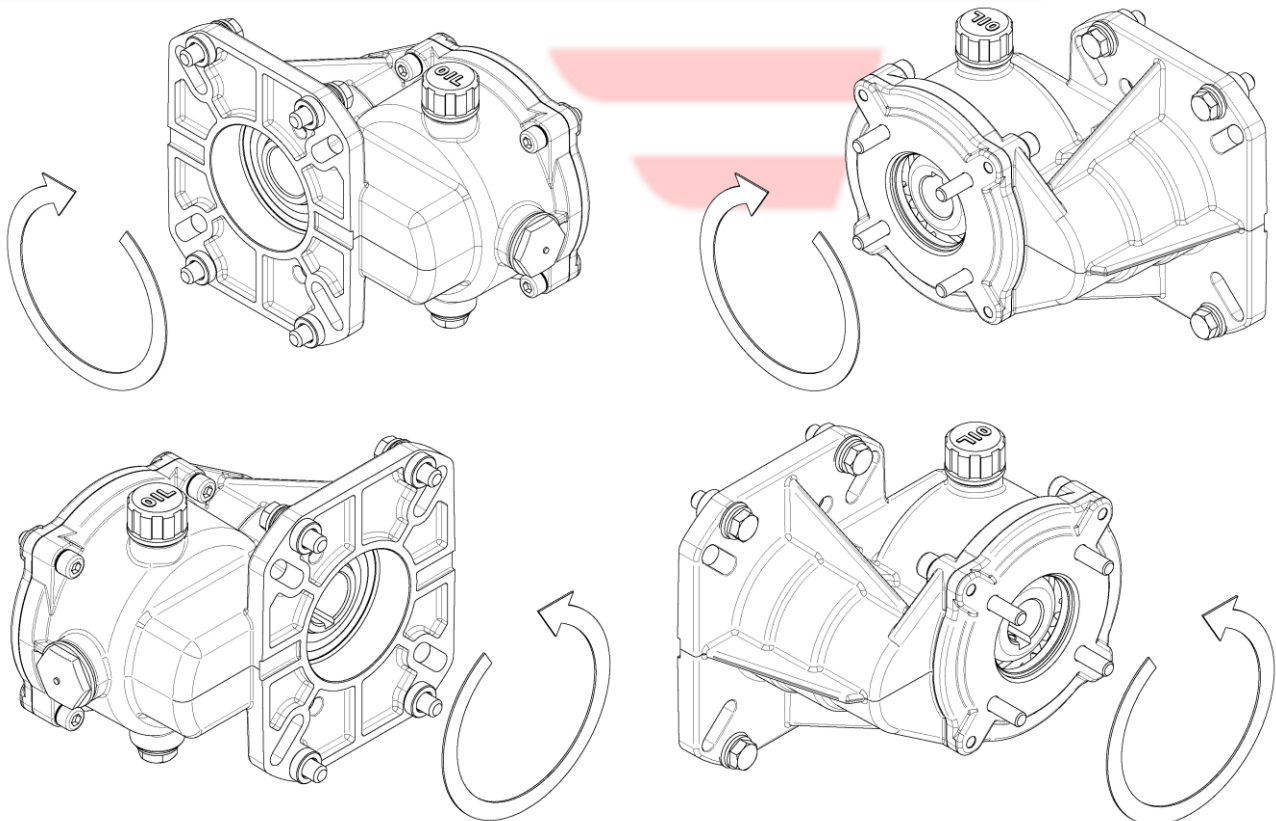

INGOMBRI / OVERALL DIMENSION

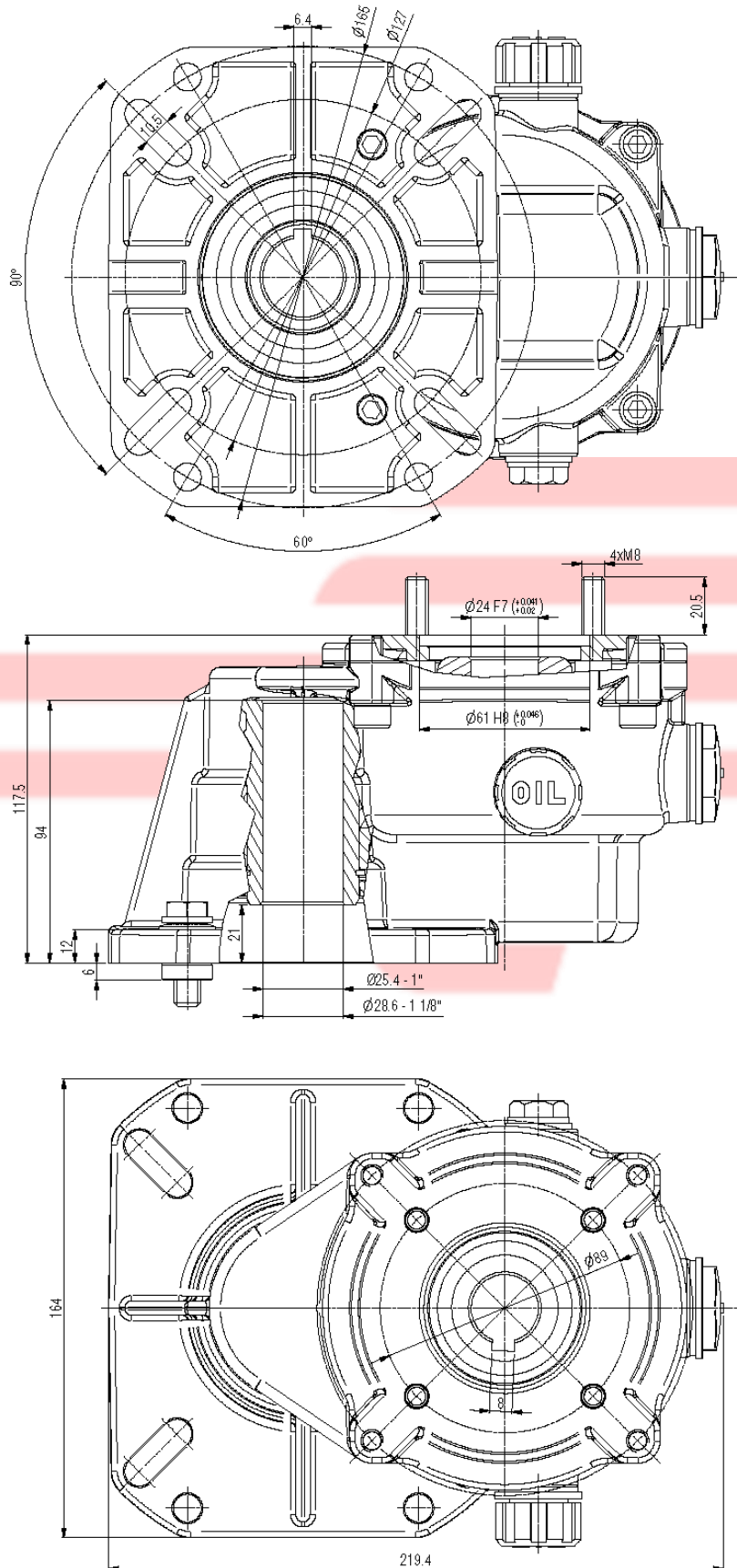

ESPLOSO / EXPLODED VIEW

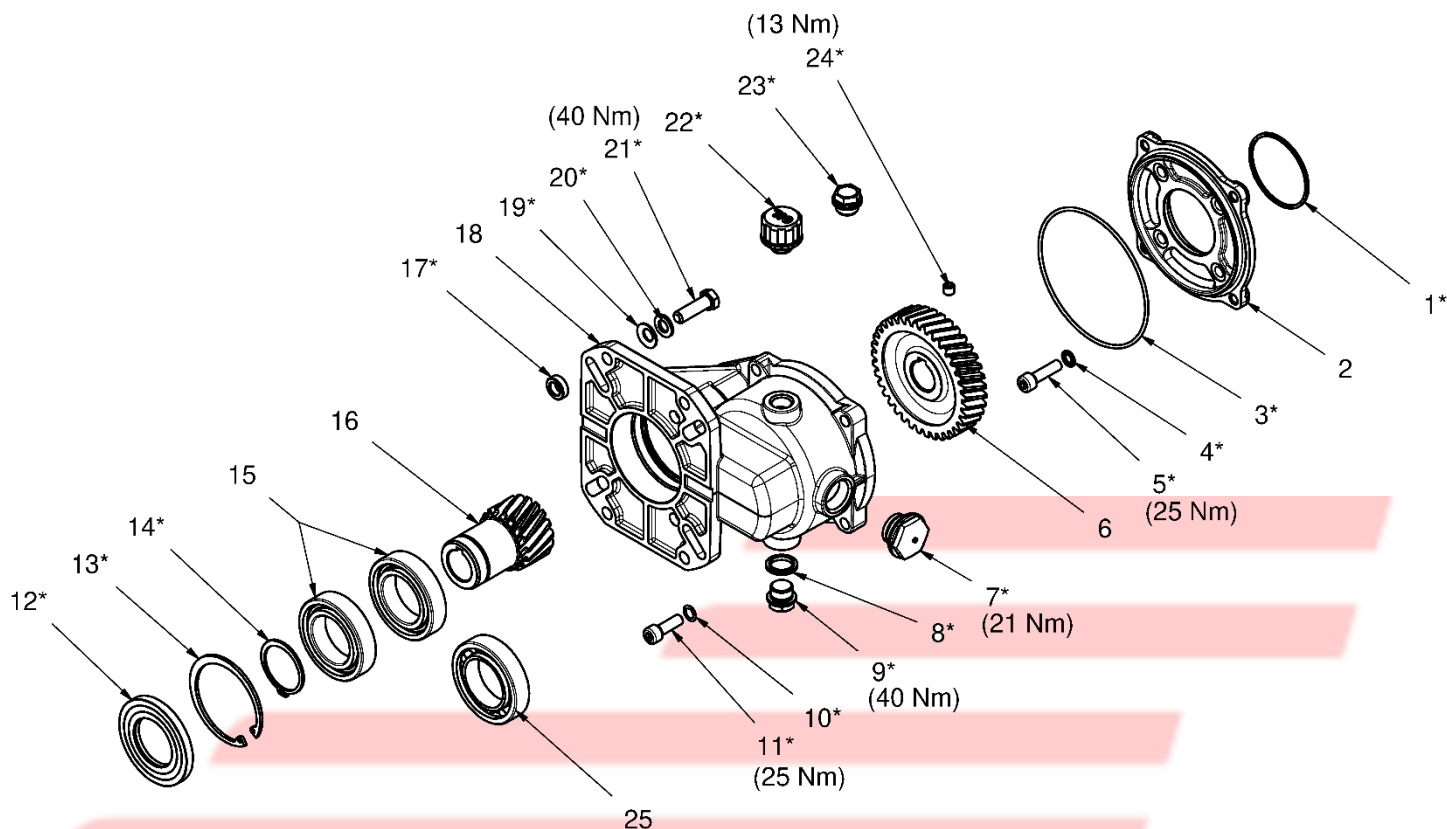

MAINTENANCE KIT / KIT MANUTENZIONE

KIT	Item - Pos	Part Number - Codice	Description	Descrizione	Q.TY by gearbox - Q.TÀ per riduttore	1.904-903.0	1.904-904.0	1.904-905.0	1.904-906.0
A	1- 3- 4- 5- 7- 8- 9- 10 11- 12- 13- 14- 17- 19 20- 21- 22- 23- 24	1.905-008.0	GEARBOX SPARE PARTS KIT	KIT RICAMBI RIDUTTORE	1	•	•	•	•

“Q.TY bt gearbox” => Necessary quantity to repair one gearbox
 “Q.TA’ per riduttore” => Quantità necessaria per riparare un riduttore

LISTA PARTI / PARTS LIST

Pos.	Codice Part Number	Descrizione	Description	Kit	Q.tà Q.ty	1.904-903.0	1.904-904.0	1.904-905.0	1.904-906.0
1*		O-RING 3225 - Ø2,62x56,82 NBR 70	O-RING 3225 - Ø2.62x56.82 NBR 70	A	1	•	•	•	•
2	9.853-477.0	FLANGIA RIDUTTORE XLTI-PXI-XXT	GEARBOX FLANGE XLTI-PXI-XXT		1	•	•	•	
	9.853-847.0	FLANGIA RIDUTTORE NMT-NPM	GEARBOX FLANGE NMT-NPM		1				•
3*		O-RING 3450 - Ø2,62x113,97 NBR 70	O-RING 3450 - Ø2.62x113.97 NBR 70	A	1				
4*		BONDED SEAL M8	BONDED SEAL M8	A	4				
5*		VITE TCEI M8x30 UNI5931 12.9 GEOMET	STUD BOLT M8x30 GEOMET	A	4				
6	9.853-896.0	CORONA Z=37-20° Ø24	RING GEAR Z=37-20° DIA. 24 mm		1				
7*		SPIA LIVELLO OLIO G 3/4	OIL SIGHT GLASS G 3/4	A	1				
8*		BONDED SEAL G 3/8 AUTOCENTRANTE	BONDED SEAL G 3/8	A	1	•	•	•	•
9*		TAPPO OTTONE G 3/8	DRAINAGE PLUG G 3/8	A	1				
10*		ROSETTA SCHNORR 08	SPRING WASHER 08	A	4				
11*		VITE TCEI M8x25 UNI5931 8.8 ZINCATA	STUD BOLT M8x25 ZINC PLATED	A	4				
12*		ANELLO RADIALE Ø40x72x7 TIPO A (NBR)	PINION OIL SEAL DIA. 40x72x7	A	1				
13*		SEEGER FORO Ø72 UNI 7437	SNAP RING DIA. 72 mm	A	1				
14*		SEEGER ALBERO Ø40 UNI 7435	SNAP RING DIA. 40 mm	A	1				
15	9.853-902.0	CUSCINETTO A SFERE 6008 40x68x15	BALL BEARING 6008 DIA. 40x68x15		→ 1	1	2	2	2
16	9.854-088.0	PIGNONE Ø1 1/8"	PINION DIA. 1 1/8"		1	•	•	•	•
	9.854-089.0	PIGNONE Ø1"	PINION DIA. 1"		1			•	•
17*		DISTANZIALE RIDUTTORE	SPACER	A	4				
18	9.854-099.0	CARTER RIDUTTORI 13-17,7-23 kW	GEARBOX CRANKCASE 13-17.7-23 kW		1				
19*		ROSETTA EL.Ø10 SCHNORR	SPRING WASHER DIA. 10 mm	A	4				
20*		ROSETTA FE Ø10x18x2 UNI1750	WASHER DIA. 10x18x2 mm	A	4				
21*		VITE TE ANSI B 18.2.1 3/8x1"1/4 UNC	HEX SCREW ANSI B 18.2.1 3/8x1"1/4 UNC	A	4	•	•	•	•
22*		TAPPO SFIATO OLIO G3/8 SPF 30-3/8+F	OIL PLUG G 3/8 SPF 30-3/8+F	A	1				
23*		TAPPO CHIUSURA CARTER G3/8 TCN/38	CRANKCASE PLUG	A	1				
24*		VITE STEI M8x8 UNI5923	GRUB SCREW M8x8	A	1				
25	9.853-903.0	CUSCINETTO RULLI CILINDRICI NJ1008	ROLLER BEARING NJ1008		1	•			

IMPORTANT

IMPORTANTE

* **Part available ONLY in kit**
Disponibile SOLO in kit