

## TECHNICAL BULLETIN

### 018

### June 2017

#### PLUNGER OIL SEAL for pumps XLT – XXT – NLT – PXI – MXT - MPX

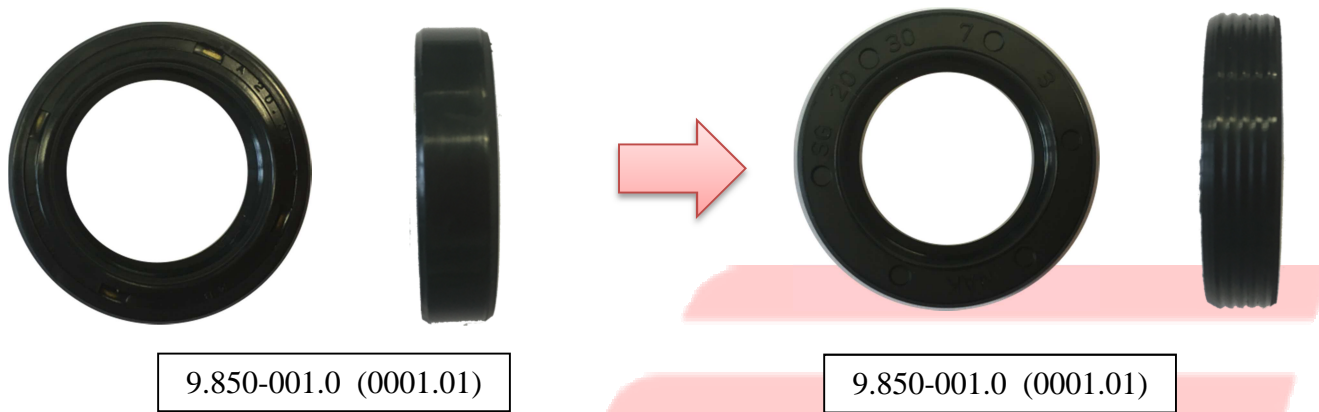

- The plunger oil seal has been upgraded to provide now better performances.
- The new plunger oil seal (2) is interchangeable with the old plunger oil seal(2)
- The kit “PLUNGER OIL SEALS” part number 1.099-766.0 is just available with the new plunger oil seal.

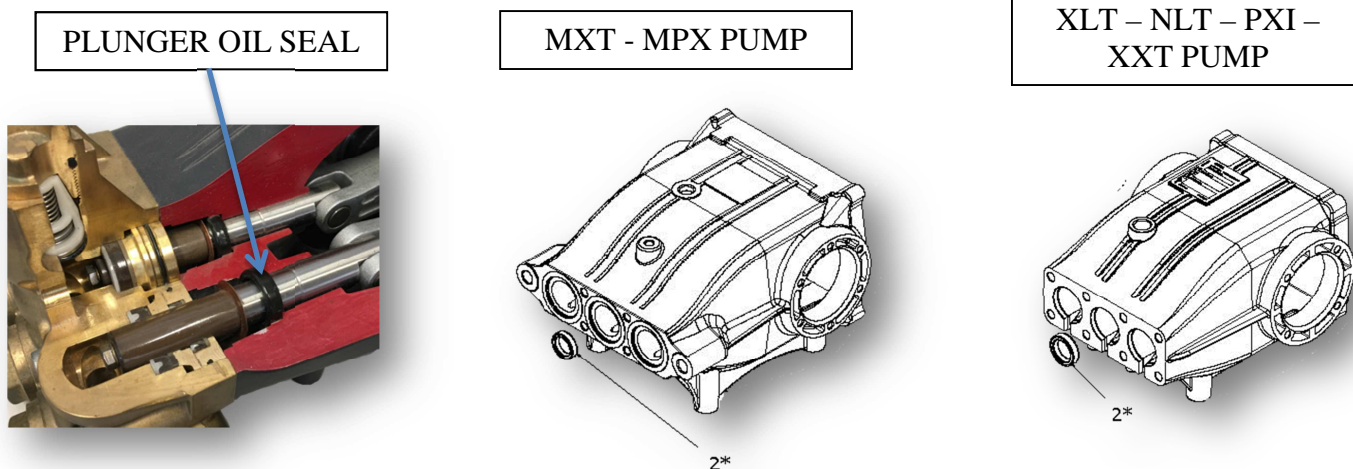

## TECHNICAL BULLETIN 018 Giugno 2017

ANELLO DI TENUTA per pompe XLT – XXT – NLT – PXI – MXT - MPX

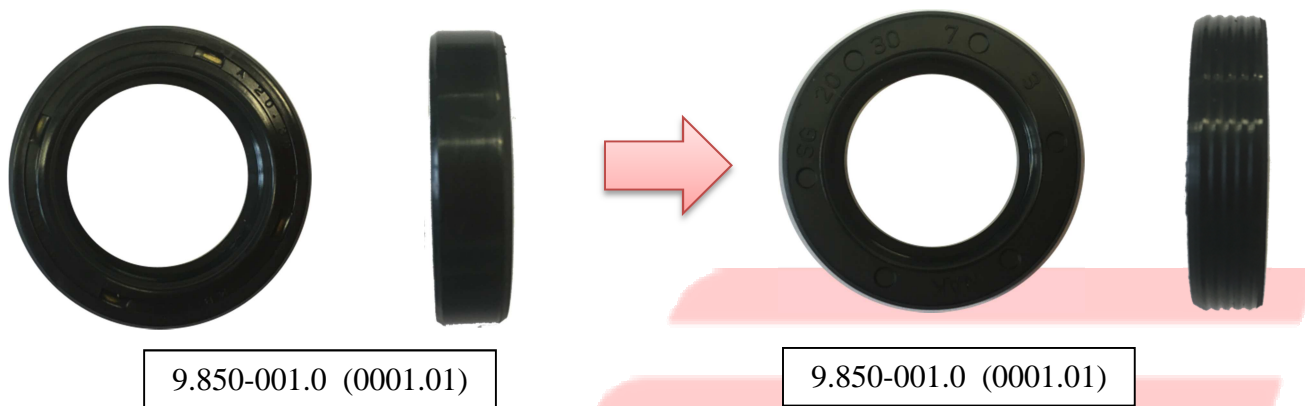

- L'anello di tenuta olio è stato cambiato per migliorare le prestazioni e la durata nelle pompe.
- Il nuovo anello di tenuta (2) è intercambiabile con il vecchio anello di tenuta(2)
- Il kit "TENUTE OLIO ASTA PISTONE" codice 1.099-766.0 è già disponibile col nuovo anello di tenuta

ANELLO DI TENUTA

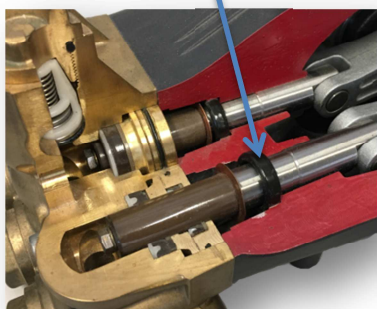

POMPA MXT - MPX

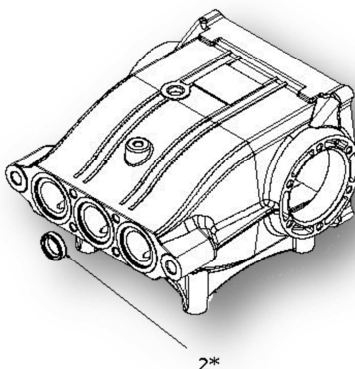

POMPA  
XLT – NLT – PXI –  
XXT

