

Pump Pompa	Pressure Pressione		Volume Portata				RPM giri/min		Power Potenza			
			l/min		GPM				HP		kW	
	bar	PSI	50 Hz	60 Hz	50 Hz	60 Hz	50 Hz	60 Hz	50 Hz	60 Hz	50 Hz	60 Hz
GPX2560S	600	8700	25	30	6.61	7.93	1000	1200	38.8	46.6	28.5	31.0
GPX3060S	600	8700	30	36	7.93	9.51	1000	1200	44.9	53.9	33.1	39.7

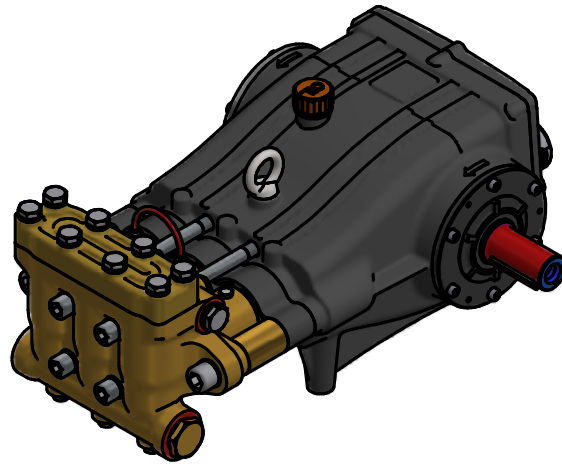

Dimensioni d'ingombro

Overall dimensions

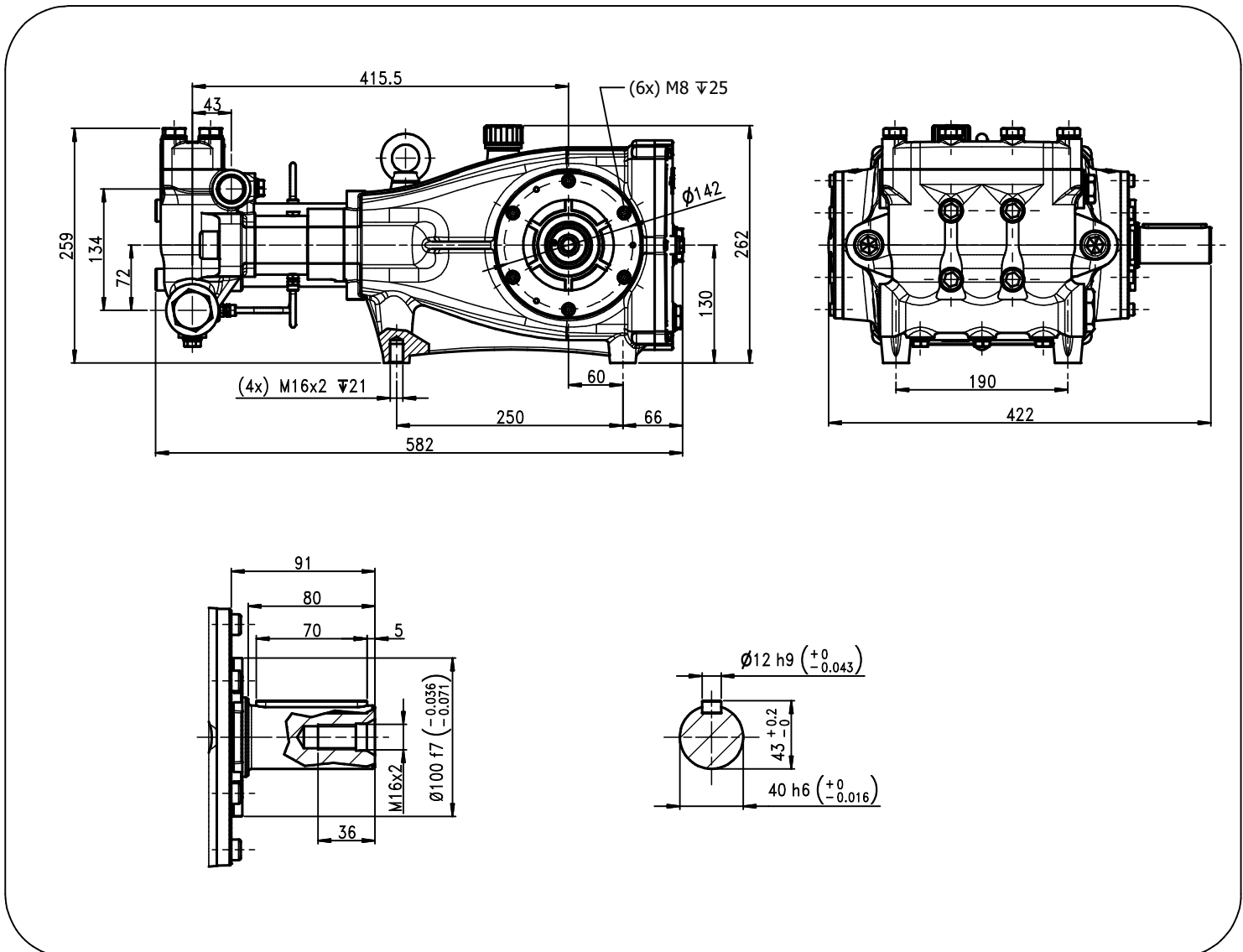

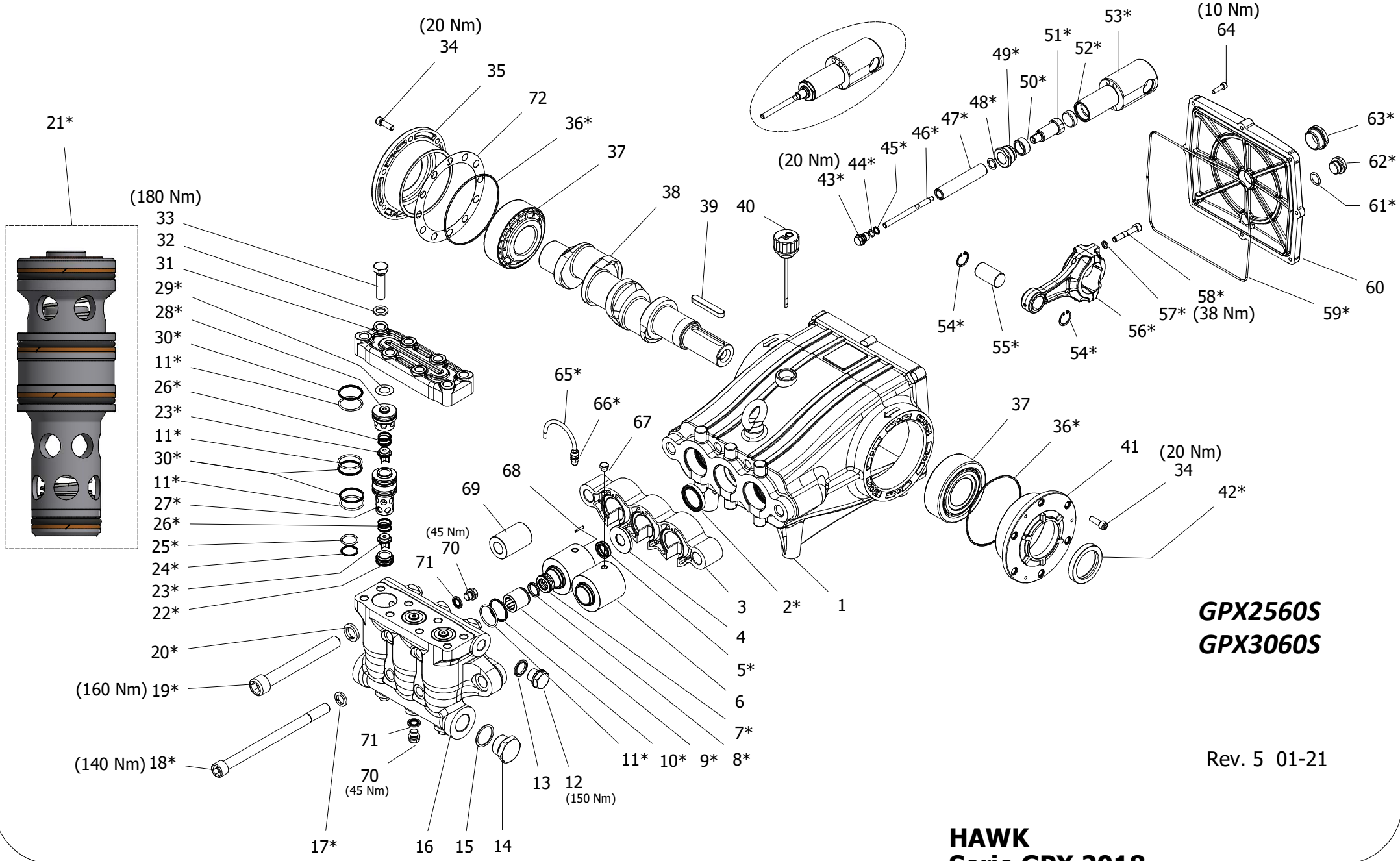

**GPX2560S**  
**GPX3060S**

Rev. 5 01-21

**HAWK**  
**Serie GPX 2018**  
**GPX 2018 Series**

## GPX SERIES 2018

### ORDINARY MAINTENANCE KIT / KIT MANUTENZIONE ORDINARIA

KIT	Item Pos.	Part Number Codice	Description	Descrizione	Q.TY by Pump Q.TA per Pompa	GPX2560S	GPX3060S
A	5- 7- 8- 9- 10- 11	1.905-626.0	PISTON SEAL PACKING Ø20	GUARNIZIONI PISTONE Ø20	1	•	•
B	21 (11- 22- 23 24- 25- 26- 27 28- 29- 30)	1.905-627.0	VALVE	VALVOLA	1	•	•

### EXTRAORDINARY MAINTENANCE KIT / KIT MANUTENZIONE STRAORDINARIA

KIT	Item Pos.	Part Number Codice	Description	Descrizione	Q.TY by Pump Q.TA per Pompa	GPX2560S	GPX3060S
C	43- 44- 45 47- 48	1.905-628.0	PLUNGER Ø20	PISTONE Ø20	3	•	•
D	36- 42- 59- 61 62- 63	1.904-474.0	KIT CRANCKASE SEALS	KIT TENUTE CARTER	1	•	•
E	17- 18- 19- 20	1.904-472.0	MANIFOLD SCREWS	VITI TESTATA	1	•	•
F	43- 44- 45- 46 48- 49- 50- 51 52- 53- 54- 55 56- 57- 58	1.905-629.0	PLUNGER ROD-CONNECTING ROD	ASTA PISTONE-BIELLA	3	•	•
G	65- 66	1.904-477.0	COMPLETE CIRCULATION PIPES	TUBI RICIRCOLO	1	•	•
I	2	1.904-478.0	PLUNGER OIL SEALS	TENUTE OLIO ASTA PISTONE	1	•	•

“Q.TY per pump” => Necessary quantity to repair one pump  
 “Q.TA’ per pompa” => Quantità necessaria per riparare una pompa

## TOOL KIT

<i>Part Number Codice</i>	<i>Description</i>	<i>Descrizione</i>	<i>Q.TY by Pump Q.TÀ per Pompa</i>	<i>GPX2560S</i>	<i>GPX3060S</i>
1.905-635.0	TOOL-KIT	TOOL-KIT	1		
1.905-636.0	OIL SEAL EXTRACTOR TOOL-KIT	TOOL-KIT ESTR. PARAOLIO	1	•	•

### **IMPORTANT**

### **IMPORTANTE**

**\*** *Part available ONLY in kit*  
Disponibile SOLO in kit

**(...)** *Parts pre-assembled*  
Parti pre-assemblate

## PARTS LIST LISTA PARTI

Item Pos	Part Number Codice	Description	Descrizione	KIT	Q.TY Q.TÀ	GPX2560S	GPX3060S
1	9.850-372.0	CRANCKCASE	CARTER		1		
2*		OIL SEAL	ANELLO RADIALE	I	3		
3	9.850-361.0	SPACER	DISTANZIALE CARTER		1		
4	9.853-295.0	SUPPORT RING Ø20	PRESSORE Ø20		3		
5*		"U" LP SEAL Ø20	TENUTA BASSA PRESSIONE Ø20	A	3		
6	9.850-494.0	INTERMEDIATE RING Ø20	DIFFUSORE Ø20		3		
7*		"U" HP SEAL Ø20	TENUTA ALTA PRESSIONE Ø20	A	3		
8*		SCRAPER Ø20	RASCHIATORE PISTONE Ø20	A	3		
9*		BUSH GUIDE Ø20	BOCCOLA GUIDA Ø20	A	3		
10*		BACK RING OR3137	ANELLO ANTIESTR. OR3137	A	3		
11*		O-RING 3137 – NBR90	O-RING 3137 – NBR90	A	12		
12	9.851-328.0	STAINLESS STEEL PLUG G1/2"	TAPPO G1/2" INOX		1		
13	9.851-192.0	BONDED SEAL G1/2"	BONDED SEAL G 1/2"		1		
14	9.851-331.0	PLUG G1"	TAPPO G1"		1		
15	9.850-752.0	COPPER WASHER G1"	GUARNIZIONE G1"		1		
16	9.851-409.0	MANIFOLD	TESTATA		1		
17*		WASHER M16	ROSETTA M16	E	4		
18*		SCREW M16x240	VITE TCEI M16x240	E	4		
19*		SCREW M20x170	VITE TCEI M20x170	E	2		
20*		SPRING WASHER M20	ROSETTA ELASTICA M20	E	2		
21*		VALVE ASSEMBLY	PREMONATATO VALVOLA	B	6		
22*		VALVE SEAT	SEDE VALVOLA	B	3		
23*		VALVE PLATE	PIATTELLO VALVOLA	B	6		
24*		BACK RING OR3093	ANELLO ANTIESTR. OR3093	B	3		
25*		O-RING 3093 – NBR70	O-RING 3093 – NBR70	B	6		
26*		SPRING	MOLLA	B	6		
27*		VALVE CAGE	GABBIA VALVOLA	B	6		
28*		VALVE CAGE	GABBIA VALVOLA	B	6		
29*		VALVE SPACER	DISTANZIALE VALVOLA	B	6		
30*		BACK RING OR3137	ANELLO ANTIESTR. OR3137	B	9		
31	9.853-647.0	MANIFOLD COVER	COPERCHIO TESTATA		1		
32	9.853-652.0	WASHER M14	ROSETTA M14		8		
33	9.853-651.0	SCREW M14x55	VITE TE M14x55		8		
34	9.851-468.0	SCREW M8x25	VITE TCEI M8x25		12		
35	9.850-646.0	CLOSED HOUSING	FLANGIA CHIUSA		1		
36		O-RING 3475 – NBR70	O-RING 3475 – NBR70	D	2		
37	9.850-353.0	BEARING	CUSCINETTO		2		

Item Pos	Part Number Codice	Description	Descrizione	Kit	Q.TY Q.TÀ	GPX2560S	GPX3060S
38	9.853-654.0	CRANKSHAFT "H"	ALBERO "H"		1		•
	9.853-655.0	CRANKSHAFT "I"	ALBERO "I"		1	•	
39	9.850-449.0	CRANKSHAFT KEY	CHIAVETTA		1		
40	9.851-284.0	OIL DIP STICK G3/4	TAPPO SFIATO OLIO G3/4		1		
41	9.850-645.0	BEARING HOUSING	FLANGIA APERTA		1		
42*		OIL SEAL	ANELLO RADIALE	D	1		
43*		PLUNGER NUT	DADO PISTONE	C - F	3		
44*		O-RING 2037 - NBR70	O-RING 2037 - NBR70	C - F	3		
45*		BACK RING OR2037	ANELLO ANTIESTR. OR2037	C - F	3		
46*		PLUNGER SCREW	TIRANTE PISTONE	F	3		
47*		PLUGER Ø20	PISTONE Ø20	C	3		
48*		PLUGER WASHER	ROSETTA PISTONE	C - F	3		
49*		NUT	DADO DI UNIONE	F	3		
50*		ELASTIC BOWL	BOCCOLA ELASTICO	F	3		
51*		PLUNGER SPACER	DISTANZIALE ASTA	F	3		
52*		PRESSURE DISC	DISCO DI PRESSIONE	F	3		
53*		PLUNGER ROD	ASTA PATTINO	F	3		
54*		SEEGER	ANELLO SEEGER	F	6		
55*		CONNECTING ROD PIN	SPINOTTO	F	3		
56*		CONNECTING ROD	BIELLA	F	3	•	•
57*		WASHER M8	ROSETTA ELASTICA M8	F	6		
58*		SCREW M8x50	VITE TCEI M8x50	F	6		
59*		O-RING Ø2,62x255 - NBR90	O-RING Ø2,62x255 - NBR90	D	1		
60	9.850-395.0	CRANCKCASE COVER	COPERCHIO CARTER		1		
61*		O-RING 3068 - NBR70	O-RING 3068 - NBR70	D	1		
62*		PLUG G 1/2"	TAPPO G1/2"	D	1		
63*		SIGHT GLASS G1"	SPIA LIVELLO G1"	D	1		
64	9.851-480.0	SCREW M6x22	VITE TCEI M6x22		8		
65*		RED RILSAN PIPE 6/4	TUBO RILSAN 6/4 ROSSO	G	3		
66*		FITTING G1/8-6/4	RACCORDO G1/8-6/4	G	6		
67	9.851-353.0	PLUG G1/8	TAPPO G1/8		1		
68	9.851-256.0	PIN	SPINA CILINDRICA		3		
69	9.853-834.0	CYLINDER HEAD SPACER	DISTANZIALE TESTATA		2		
70	9.851-305.0	PLUG G1/4	TAPPO G1/4		6		
71	9.853-581.0	BONDED SEAL G1/4	BONDED SEAL G1/4		6		
72	9.850-549.0	SHIM	DISTANZIALE FLANGIA		1		