

NHDP – 120 BAR

Caratteristiche Tecniche

Albero maschio – Solid shaft

Technical Characteristics

Pump Pompa	Pressure Pressione		Volume Portata				RPM giri/min		Power Potenza			
			l/min		GPM				HP		kW	
	bar	PSI	50 Hz	60 Hz	50 Hz	60 Hz	50 Hz	60 Hz	50 Hz	60 Hz	50 Hz	60 Hz
NHDP0412	120	1740	4	4.8	1.1	1.3	1450	1740	1.2	1.5	0.9	1.1
NHDP0612	120	1740	6	7.2	1.6	1.9	1450	1740	1.9	2.3	1.4	2.3
NHDP8512	120	1740	8.5	10.1	2.2	2.7	1450	1740	2.6	3.1	1.9	2.3
NHDP1012	120	1740	10	12	2.6	3.2	1450	1740	3.0	3.6	2.2	2.6
NHDP1112	120	1740	11	13.2	2.9	3.5	1450	1740	3.4	4.1	2.5	3.0
NHDP1212	120	1740	12	14	3.1	3.7	1450	1740	3.6	4.4	2.7	3.2

Dimensioni d'ingombro

Overall dimensions

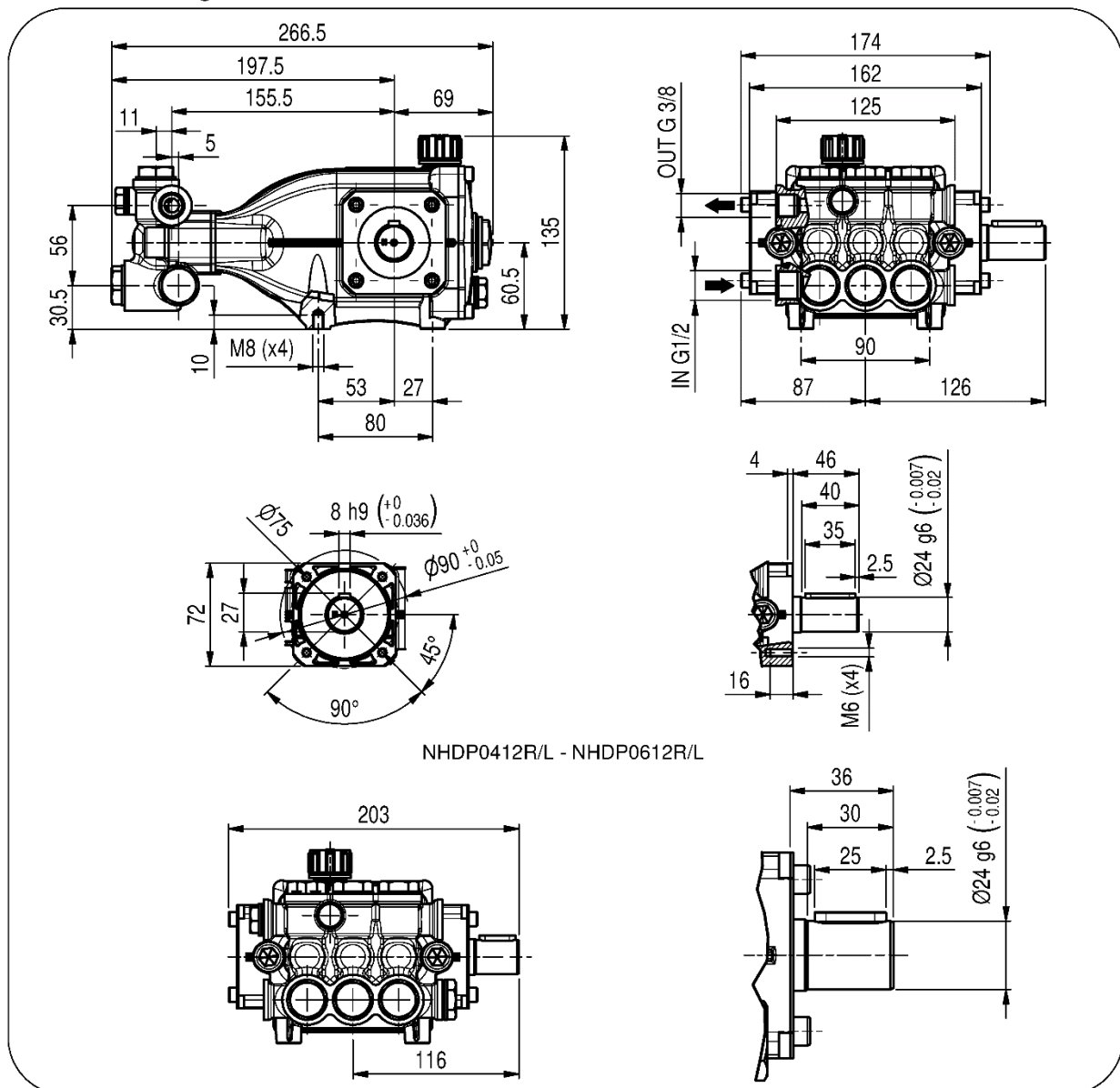

NHDP0412R/L - NHDP0612R/L

Lubrificazione: Olio SAE 10W40
Capacità: 0.4 Litri
Peso pompa: 8.2kg

Lubrication: SAE 10W40 Oil
Capacity: 0.4 Litres
Weight: 8.2 kg

LEUCO S.p.A.

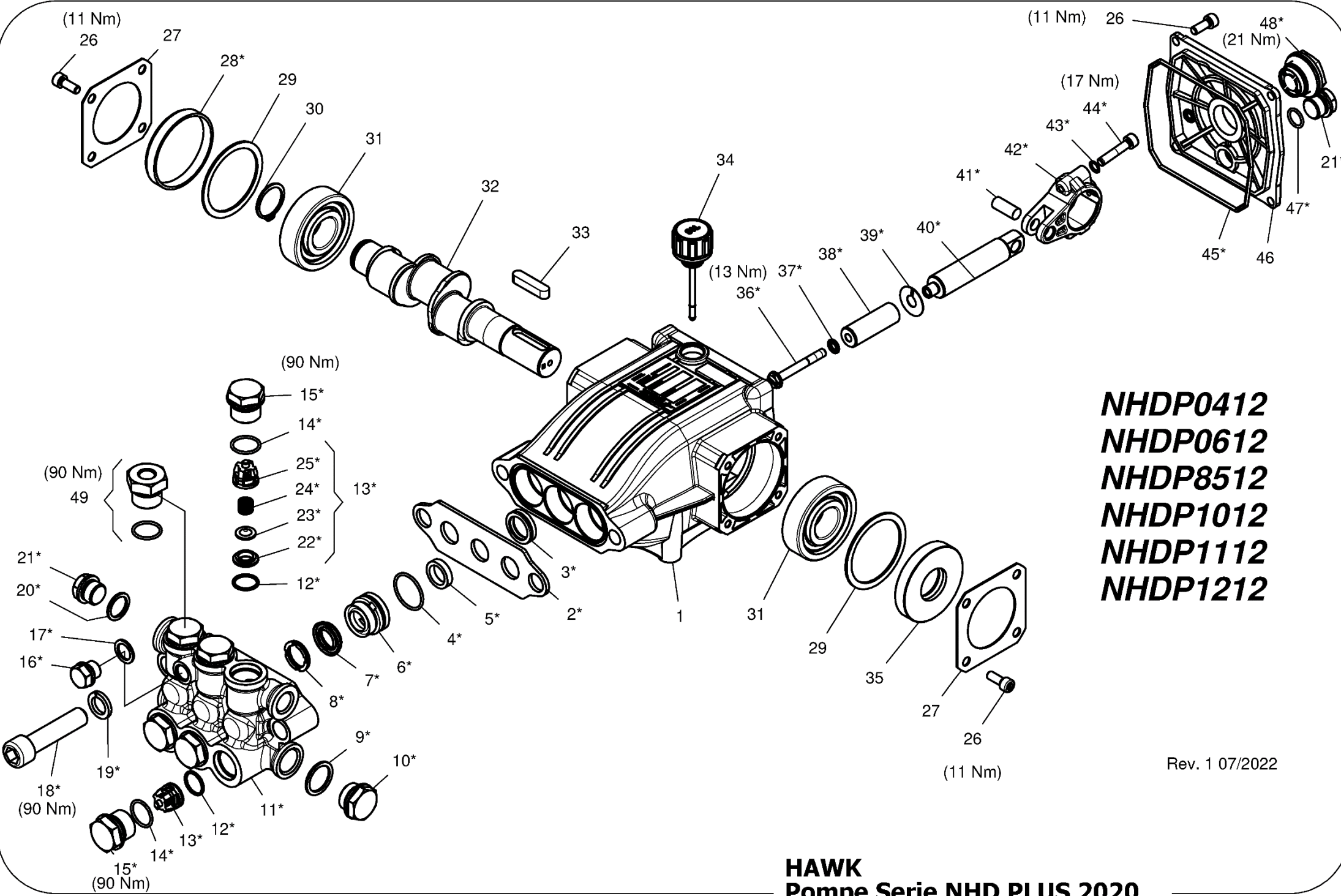

NHDP0412
NHDP0612
NHDP8512
NHDP1012
NHDP1112
NHDP1212

Rev. 1 07/2022

HAWK
Pompe Serie NHD PLUS 2020
NHD PLUS Pumps 2020 Serie

NHDP 2020 SERIES

ORDINARY MAINTENANCE KIT / KIT MANUTENZIONE ORDINARIA

KIT	Item Pos.	Part Number Codice	Description	Descrizione	Q.TY by Pump Q.TA per Pompa	NHDP0412R/L	NHDP0612R/L	NHDP8512R/L	NHDP1012R/L	NHDP1112R/L	NHDP1212R/L
A	4- 5 - 6 - 7- 8 18	1.904-739.0	PLUNGER SEALS DIA. 16 mm	GUARNIZIONI PISTONE Ø16	1						
B	12- 13 (22- 23 24- 25) -15	1.905-617.0	COMPLETE VALVE	VALVOLA COMPLETA	1	•	•	•	•	•	•

EXTRAORDINARY MAINTENANCE KIT / KIT MANUTENZIONE STRAORDINARIA

KIT	Item Pos.	Part Number Codice	Description	Descrizione	Q.TY by Pump Q.TA per Pompa	NHDP0412R/L	NHDP0612R/L	NHDP8512R/L	NHDP1012R/L	NHDP1112R/L	NHDP1212R/L
C	36 - 37- 38- 39	1.099-738.0	PLUNGER DIA. 16 mm	PISTONE Ø16	3						
D	3	1.099-740.0	PLUNGER OIL SEALS	ANELLI TENUTA OLIO ASTA	1						
E	21- 28- 35- 45 47- 48	1.905-624.0	KIT CRANKCASE SEALS	KIT TENUTE CARTER	1						
F	4 - 5- 6- 7 8 - 9- 10- 11- 12 13(21 - 22- 23 - 24) - 16 - 17- 18 - 19- 20- 21	1.904-740.0	COMPLETE MANIFOLD	TESTATA COMPLETA	1	•	•	•	•	•	•
G	40 - 41- 42- 43- 44	1.905-742.0	CONNECTING ROD PLUNGER ROD ASSY	PREMONTATO ASTA-BIELLA PISTONE	3						
H	14- 15	1.904-249.0	VALVE PLUG ASSY	PREMONTATO TAPPO VAM	6						

“Q.TY by Pump” => Necessary quantity to repair one pump
 “Q.TA’ per Pompa” => Quantità necessaria per riparare una pompa

OPTIONAL

Item Pos.	Part Number Codice	Description	Descrizione	Q.TY by Pump Q.TA per Pompa	NHDP0412R/L	NHDP0612R/L	NHDP8512R/L	NHDP1012R/L	NHDP1112R/L	NHDP1212R/L
49	9.853-424.0	THREADED BRASS PLUG G1/4	PREMONTATO TAPPO FORATO	1	•	•	•	•	•	•

TOOL KIT

Part Number Codice	Description	Descrizione	Q.TY by Pump Q.TA per Pompa	NHDP0412R/L	NHDP0612R/L	NHDP8512R/L	NHDP1012R/L	NHDP1112R/L	NHDP1212R/L
1.904-744.0	TOOL-KIT	TOOL-KIT	1	•	•	•	•	•	•
1.905-591.0	TOOL-KIT EXTRAORDINARY	TOOL-KIT MANUTENZIONE STRAORINARIA	1	•	•	•	•	•	•

IMPORTANT

IMPORTANTE

* Part available **ONLY** in kit
Disponibile **SOLO** in kit

(...) Parts pre-assembled
Parti pre-assemblate

PARTS LIST LISTA PARTI

Item Pos	Part Number Codice	Description	Descrizione	KIT	Q. TY Q. T A	NHDP0412R/L	NHDP0612R/L	NHDP8512R/L	NHDP1012R/L	NHDP1112R/L	NHDP1212R/L
1	9.850-369.0	CRANKCASE	CARTER		1						
2	9.853-555.0	NHD PLUS CYLINDERHEAD SPACER	DISTANZIALE TESTATA NHD PLUS		1						
3*		PLUNGER OIL SEAL	ANELLO RADIALE	D	3						
4*		"O" RING Ø1.78X26.7	"O" RING Ø1.78X26.7	A-F	3						
5*		"U" SEAL, DIA. 16 MM	ANELLO TENUTA "U" Ø16	A-F	3						
6*		PRESSURE RING DIA. 16 MM	PRESSORE Ø16 "V" PLASTICA (NHD)	A-F	3						
7*		"V" SEAL, DIA. 16 MM	ANELLO TENUTA "V" Ø16	A-F	3						
8*		SUPPORT RING DIA. 16 MM	DIFFUSORE Ø16	A-F	3						
9*		COPPER WASHER G1/2	GUARNIZIONE RAME G1/2	F	1						
10*		BRASS PLUG G1/2	TAPPO OTTONE G1/2	F	1						
11*		CYLINDERHEAD	TESTATA NHD PLUS OT58	F	1						
12*		"O" RING Ø1.78X15.6	"O" RING Ø1.78X15.6	B-F	6						
13*		VALVE ASSEMBLY	VALVOLA PREMONTATA	B-F	6						
14*		"O" RING Ø1,78X18.77	"O" RING Ø1.78X18.77	B-F-H	6						
15*		VALVE PLUG	TAPPO VALVOLA	F-H	6						
16*		BRASS PLUG G1/4	TAPPO OTTONE G1/4	F	1	•	•	•	•	•	•
17*		COPPER WASHER G1/4	GUARNIZIONE RAME G1/4	F	1						
18*		MANIFOLD STUD BOLT M14X60	VITE TCEI M14X60	A-F	2						
19*		LOCK-WASHER	ROSETTA ELASTICA Ø14	F	2						
20*		COPPER WASHER G3/8	GUARNIZIONE RAME G 3/8	F	1						
21*		BRASS PLUG G 3/8	TAPPO OTTONE G 3/8	F-E	2						
22*		VALVE SEAT	SEDE VALVOLA	B-F	6						
23*		VALVE PLATE	PIATTELLO VALVOLA	B-F	6						
24*		VALVE SPRING	MOLLA VALVOLA	B-F	6						
25*		VALVE CAGE	GABBIA VALVOLA	B-F	6						
26	9.851-474.0	SCREW M6X16	VITE TCEI M6X16		12						
27	9.850-379.0	BEARING COVER	COPERCHIO CUSCINETTO		2						
28*		BEARING SEAL	CAPPELLOTTO CUSCINETTO	E	1						
29	9.850-554.0	CRANKSHAFT SEAL SPACER	DISTANZIALE PARAOLIO ALBERO		2						
30	9.851-198.0	SNAP RING DIA. 25 MM	ANELLO Ø25		1						
31	9.850-460.0	BALL BEARING	CUSCINETTO A SFERE		2						
32	9.850-225.0	SINGLE-ENDED SHAFT	ALBERO SEMPLICE P.D.F		1						•
	9.850-226.0	" " "	" " "		1			•			
	9.850-227.0	" " "	" " "		1				•		
	9.851-956.0	" " "	" " "		1						•
	9.850-245.0	" " "	" " "		1	•					
	9.850-246.0	" " "	" " "		1		•				

Item Pos	Part Number Codice	Description	Descrizione	KIT	Q.TY Q.T À	NHDP0412R/L	NHDP0612R/L	NHDP8512R/L	NHDP1012R/L	NHDP1112R/L	NHDP1212R/L
33	9.850-446.0	CRANKSHAFT KEY	CHIAVETTA		1			•	•	•	•
	9.850-443.0	" "	"		1	•	•				
34	9.851-286.0	OIL DIP STICK	TAPPO LIVELLO OLIO		1						
35*		CRANKSHAFT SEAL	ANELLO RADIALE	E	1						
36*		PLUNGER BOLT	VITE PISTONE	C	3						
37*		BONDED SEAL - Ø6,7X11X1 AISI 304	BONDED SEAL - Ø6,7X11X1 AISI 304	C	3						
38*		PLUNGER DIA. 16 MM	PISTONE Ø16	C	3						
39*		COPPER SPACER	ROSETTA RAME	C	3						
40*		PLUNGER ROD	ASTA PISTONE	G	3						
41*		CONNECTING ROD PIN	SPINOTTO	G	3	•	•	•	•	•	•
42*		CONNECTING ROD	BIELLA	G	3						
43*		SPRING WASHER DIA. 6 MM	ROSETTA SCHNORR Ø6	G	6						
44*		CONNECTING ROD SCREW	VITE M6X30	G	6						
45*		"O" RING Ø2.62X111.62	"O" RING Ø2.62X111.62	E	1						
46	9.850-392.0	CRANKCASE COVER	COPERCHIO POSTERIORE		1						
47*		"O" RING Ø1.78X14	"O" RING Ø1.78X14	E	1						
48*		SIGHT GLASS G3/4	SPIA LIVELLI OLIO G3/4	E	1						