

VBR3050
1.905-051.0

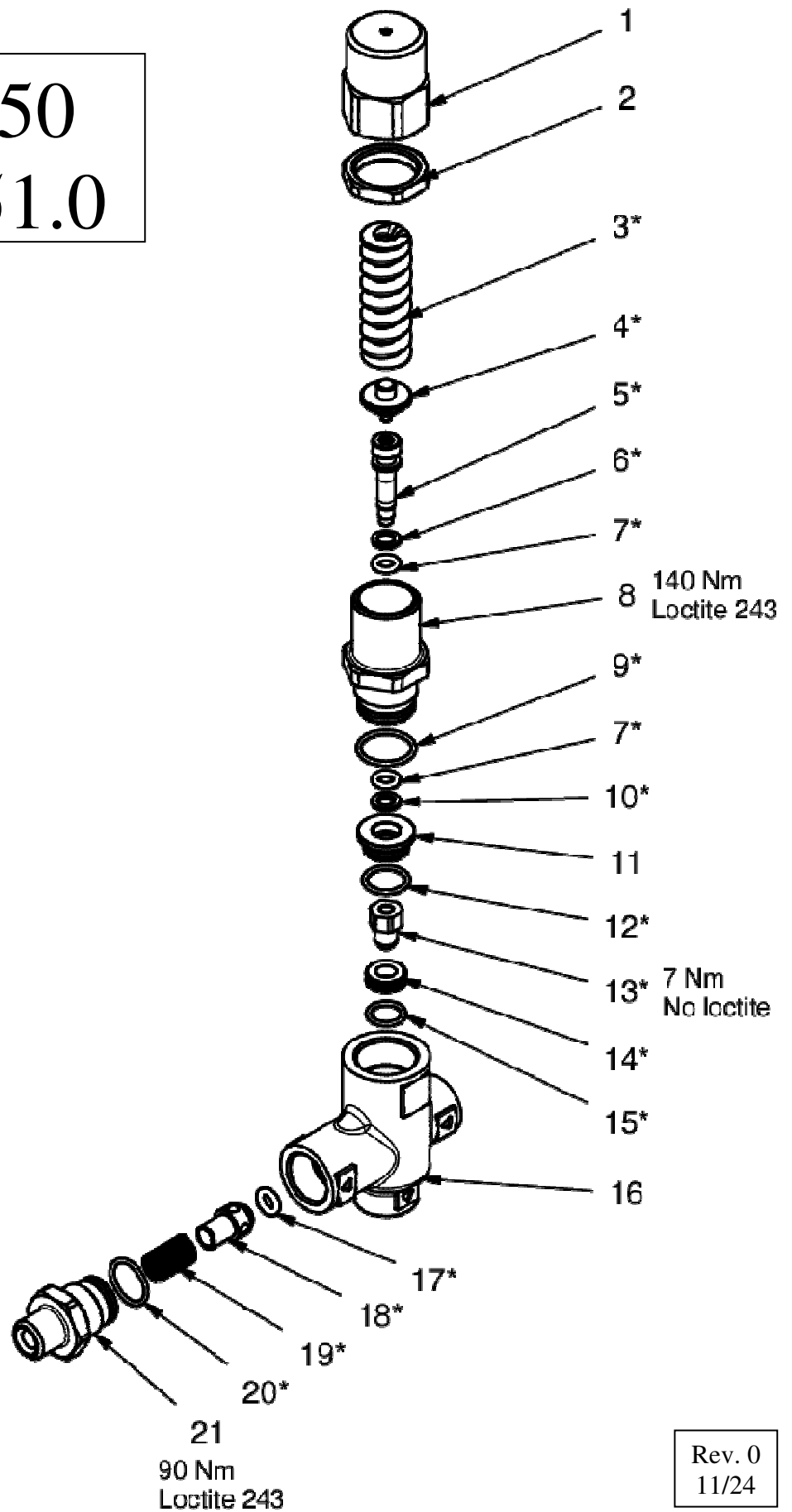

Rev. 0
11/24

CARATTERISTICHE TECNICHE

TECHNICAL CHARACTERISTICS

Codice Part No.	Pressione Max Max Pressure		Portata Flow rate		Temp. Max Max Temp.	Inlet Port Entrata	Outlet Port Uscita	By-pass
	bar	PSI	l/min	GPM	°C			
1.905-051.0	500	7250	30	8.0	65	G 3/8" F	G 3/8" M	G3/8" F

DIMENSIONI D'INGOMBRO

OVERALL DIMENSIONS

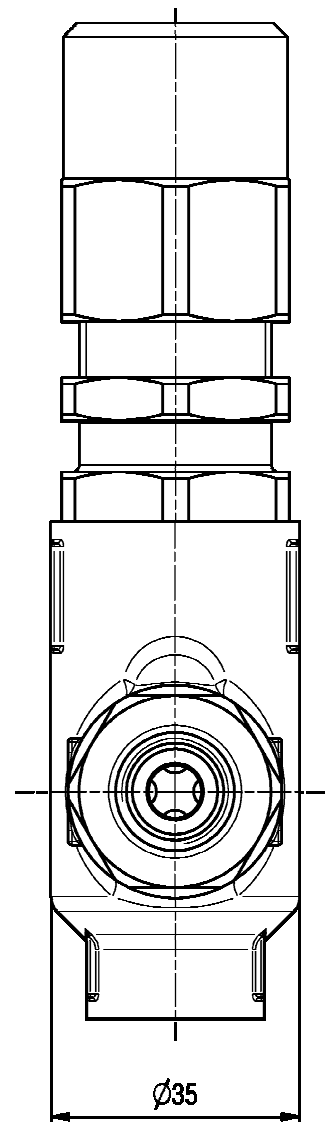
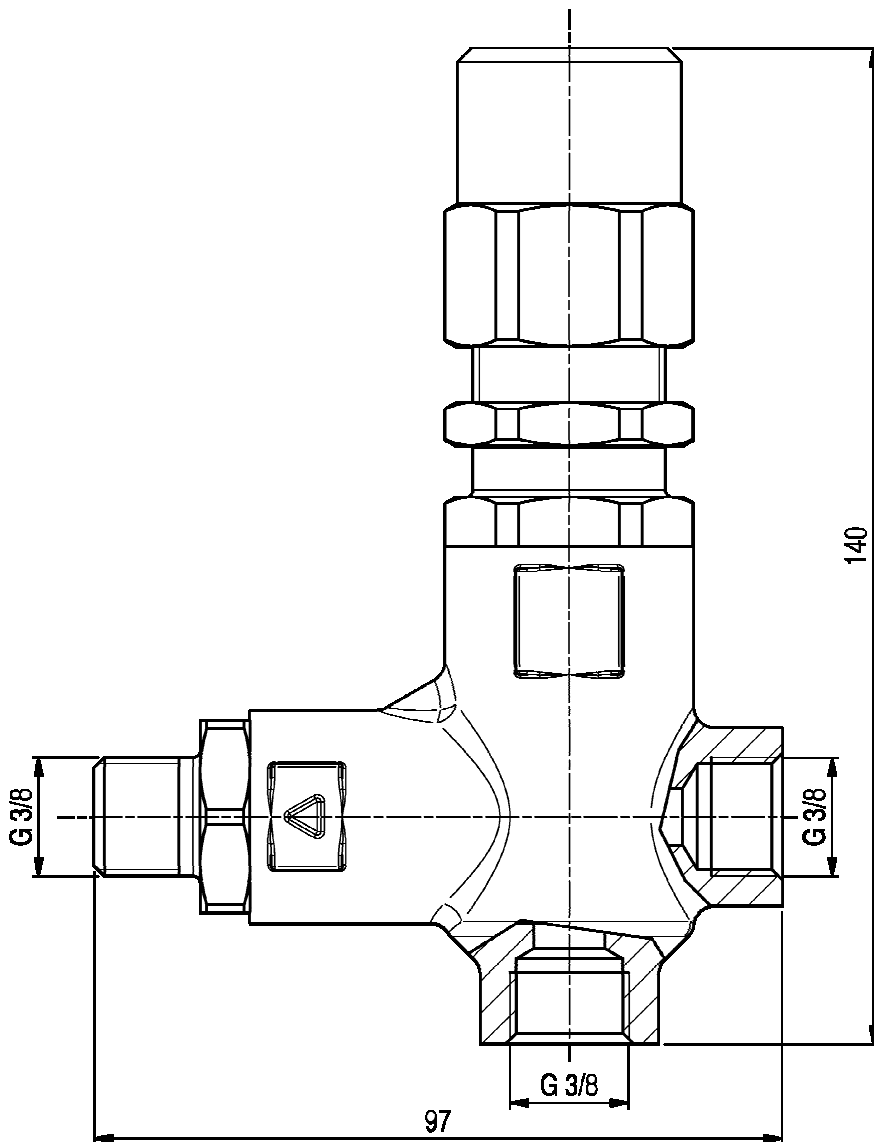

Rev. 0
11/24

SPARE PARTS KIT

KIT RICAMBI

<i>KIT</i>	<i>ITEM POS.</i>	<i>CODICE</i>	<i>DESCRIZIONE</i>	<i>DESCRIPTION</i>
A	6- 7- 9- 10 12- 15- 17- 20	1.905-053.0	KIT OR E ANTIESTRUSORI	KIT STEM SEALS
B	17- 18- 19- 20	1.905-054.0	KIT OTTURATORE	KIT OUTLET-POPPET
C	3- 4- 5- 13 14- 15	1.905-055.0	KIT PISTONE	KIT STEM REPAIR

SPARE PARTS

LISTA RICAMBI

#	Q.TA' Q.TY	CODICE	DESCRIZIONE	DESCRIPTION	KIT
1	1	9.854-003.0	MANOPOLA OTTONE	BRASS HANDLE	
2	1	9.854-004.0	DADO M27x1.5	NUT	
3*	1		MOLLA	SPRING	C
4*	1		PIATTELLO	PLATE	C
5*	1		PISTONE	STEM	C
6*	1		ANELLO ANTIESTRUSORE Ø6.5x11	STEM BACKRING	A
7*	2		OR 108 (2.62 x 6.02) 90 Sh	STEM O-RING	A
8	1	9.854-006.0	RACCORDO DI GUIDA	GUIDE CONNECTOR	
9*	1		OR 2081 (1.78 x 20.35) 90 Sh	GUIDE CONNECTOR O-RING	A
10*	1		ANELLO ANTIESTRIONE Ø7x11.5	GUIDE BUSHING BACKRING	A
11	1	9.854-008.0	BOCCOLA	GUIDE BUSHING	
12*	1		OR 2062 (1.78 x 15.6) 90 Sh	GUIDE BUSHING O-RING	A
13*	1		OTTURATORE VALVOLA	VALVE SHUTTER	C
14*	1		SEDE	SEAT	C
15*	1		OR 2050 (1.78 x 12.42) 90 Sh	SEAT O-RING	C
16	1	9.854-010.0	CORPO VALVOLA	VALVE BODY	
17*	1		OR 3x6 90 Sh	POPPET O-RING	A-B
18*	1		OTTURATORE	POPPET	B
19*	1		MOLLA OTTURATORE	POPPET SPRING	B
20*	1		OR 2068 (1.78 x 17.17) 90 Sh	OUTLET CONNECTOR O-RING	A-B
21	1	9.854-009.0	RACCORDO USCITA	OUTLET CONNECTOR	

IMPORTANT

IMPORTANTE

* **Part available ONLY in kit**
Disponibile SOLO in kit