

## CARATTERISTICHE TECNICHE

## TECHNICAL CHARACTERISTICS

Codice Part No.	Pressione Max Max Pressure		Portata Flow rate		Temp. Max Max Temp.	Inlet Port Entrata	Outlet Port Uscita
	bar	PSI	l/min	GPM	°C		
<b>1.905-850.0</b>	1000	14500	40	10.6	100	G3/8" F	G3/8" F

## DIMENSIONI D'INGOMBRO

## OVERALL DIMENSIONS

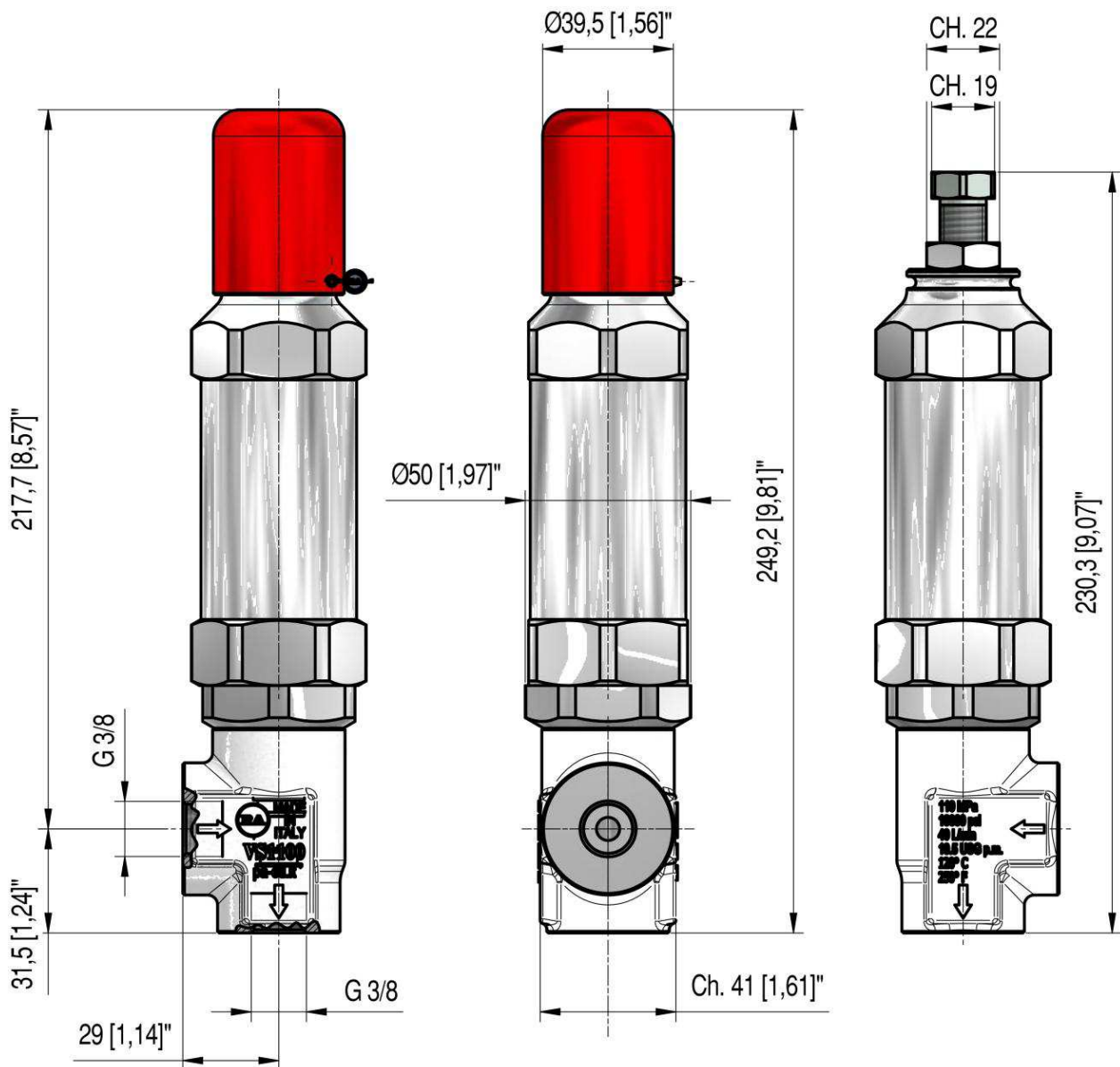

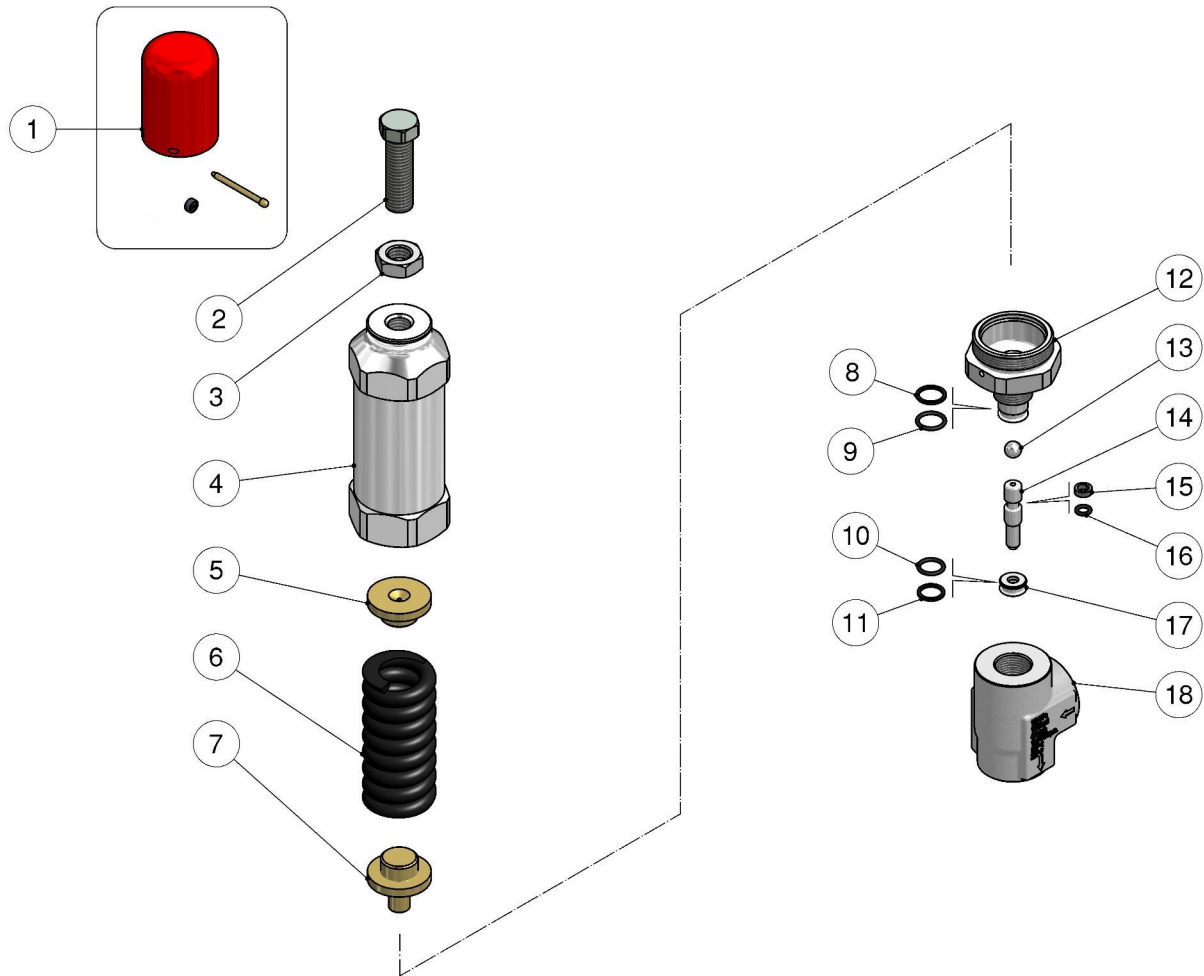

**SPARE PARTS KIT**

**KIT RICAMBIO**

CODICE CODE	POS.	Q.TA' Q.TY
<b>1.904-932.0</b>	8	1
	9	1
	10	1
	11	1
	14	1
	15	1
	16	1
	17	1