

CARATTERISTICHE TECNICHE

TECHNICAL CHARACTERISTICS

| Codice Part No. | Pressione Max Max Pressure | | Portata Flow rate | | Temp. Max Max Temp. | Inlet Port Entrata | Outlet Port Uscita |
|--------------------|----------------------------|------|-------------------|-----|---------------------|--------------------|--------------------|
| | bar | PSI | l/min | GPM | °C | | |
| 1.904-939.0 | 300 | 4350 | 450 | 120 | 90 | G1" 1/4 F | G1" 1/4 F |

DIMENSIONI D'INGOMBRO

OVERALL DIMENSIONS

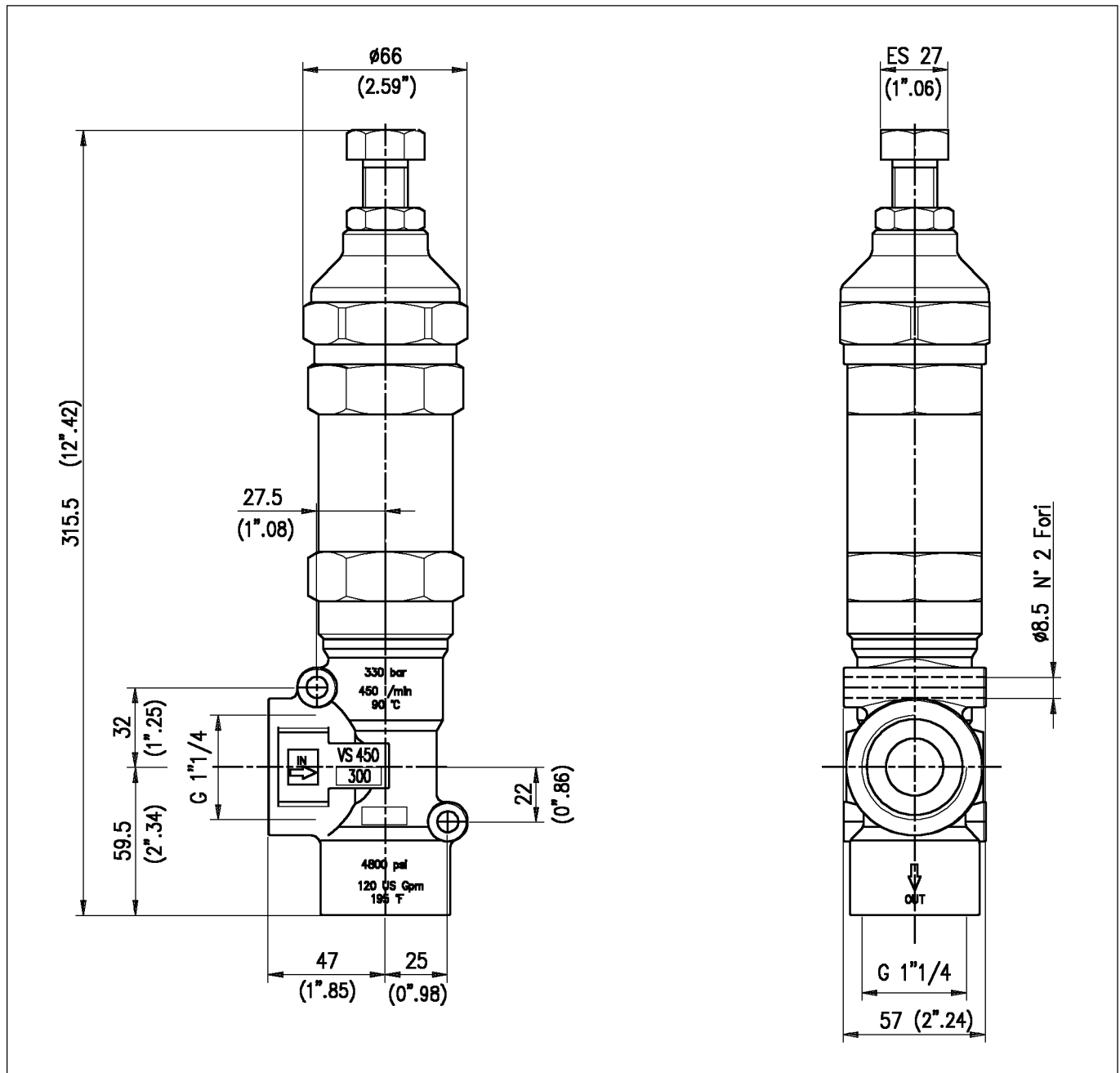

Rev. 1 09-22

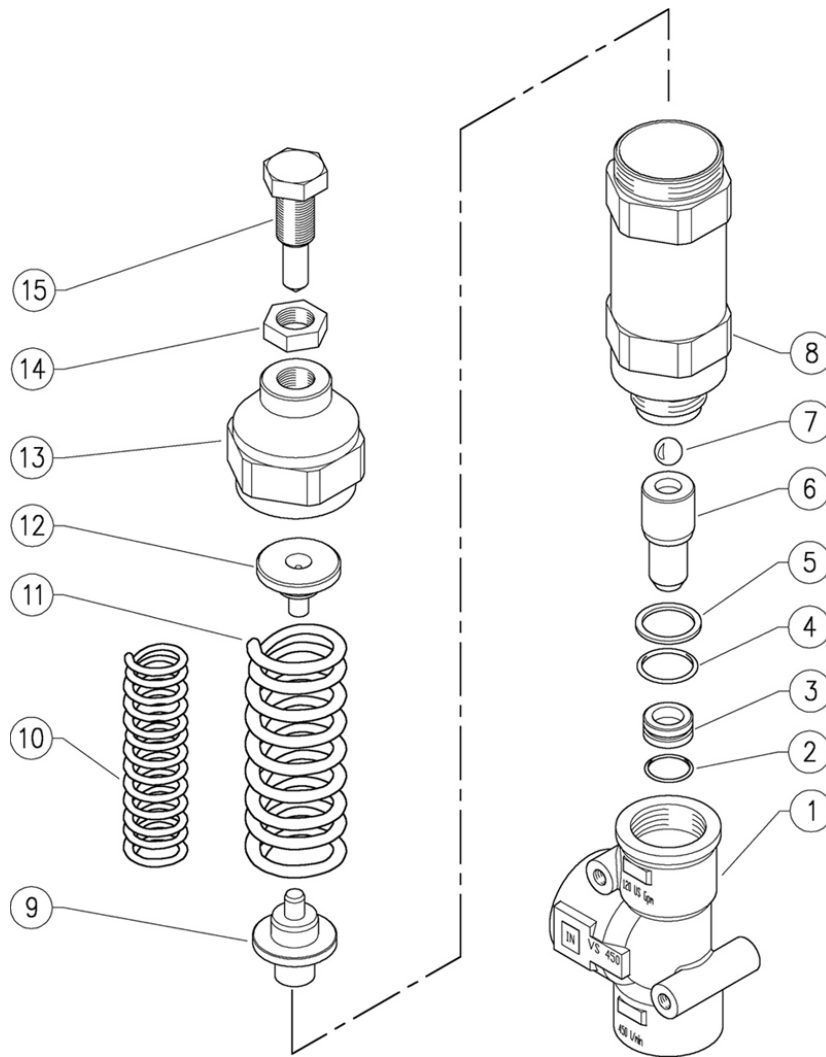

SPARE PARTS KIT

KIT RICAMBIO

| CODICE CODE | POS. | Q.TA' Q.TY |
|--------------------|------|---------------|
| 1.904-940.0 | 2 | 1 |
| | 3 | 1 |
| | 4 | 1 |
| | 5 | 1 |
| | 6 | 1 |