

NMT ESA – 200 BAR

Caratteristiche Tecniche

Albero maschio – Solid shaft

Technical Characteristics

Pump Pompa	Pressure Pressione		Volume Portata				RPM giri/min		Power Potenza			
			l/min		GPM				HP		kW	
	bar	PSI	50 Hz	60 Hz	50 Hz	60 Hz	50 Hz	60 Hz	50 Hz	60 Hz	50 Hz	60 Hz
NMT2120ESAR	200	2900	21.0	25.0	5.5	6.6	1450	1740	10.7	12.8	7.9	9.4
NMT1520ESAR	200	2900	15.0	18.0	4.0	4.7	1450	1740	7.7	9.2	5.7	6.8

Dimensioni d'ingombro

Overall dimensions

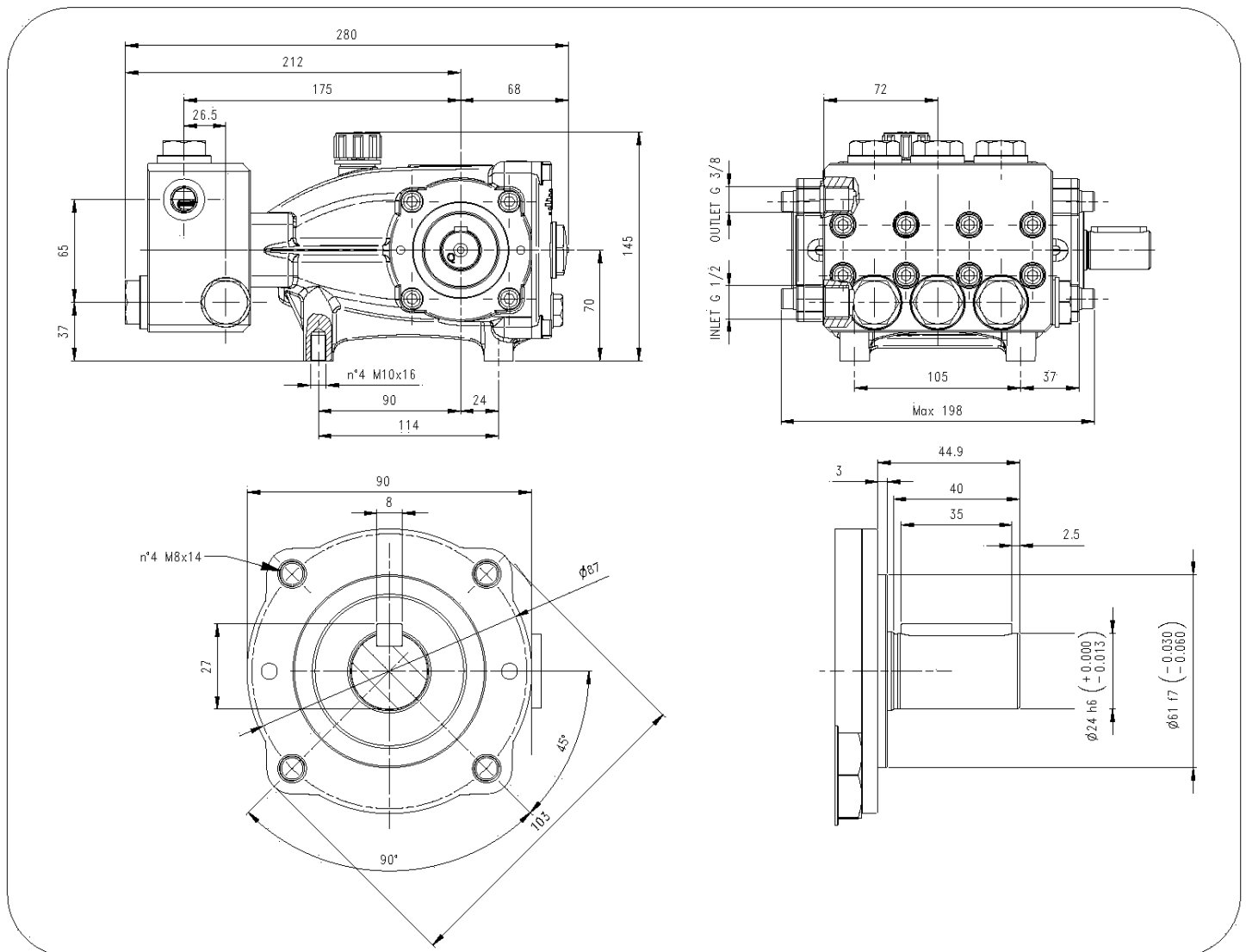

Lubrificazione: Olio SAE 10W40
 Capacità: 0.4 Litri
 Peso pompa: 11.5 kg

Lubrication: SAE 10W40 Oil
 Capacity: 0.4 Litres
 Weight: 11.5 kg

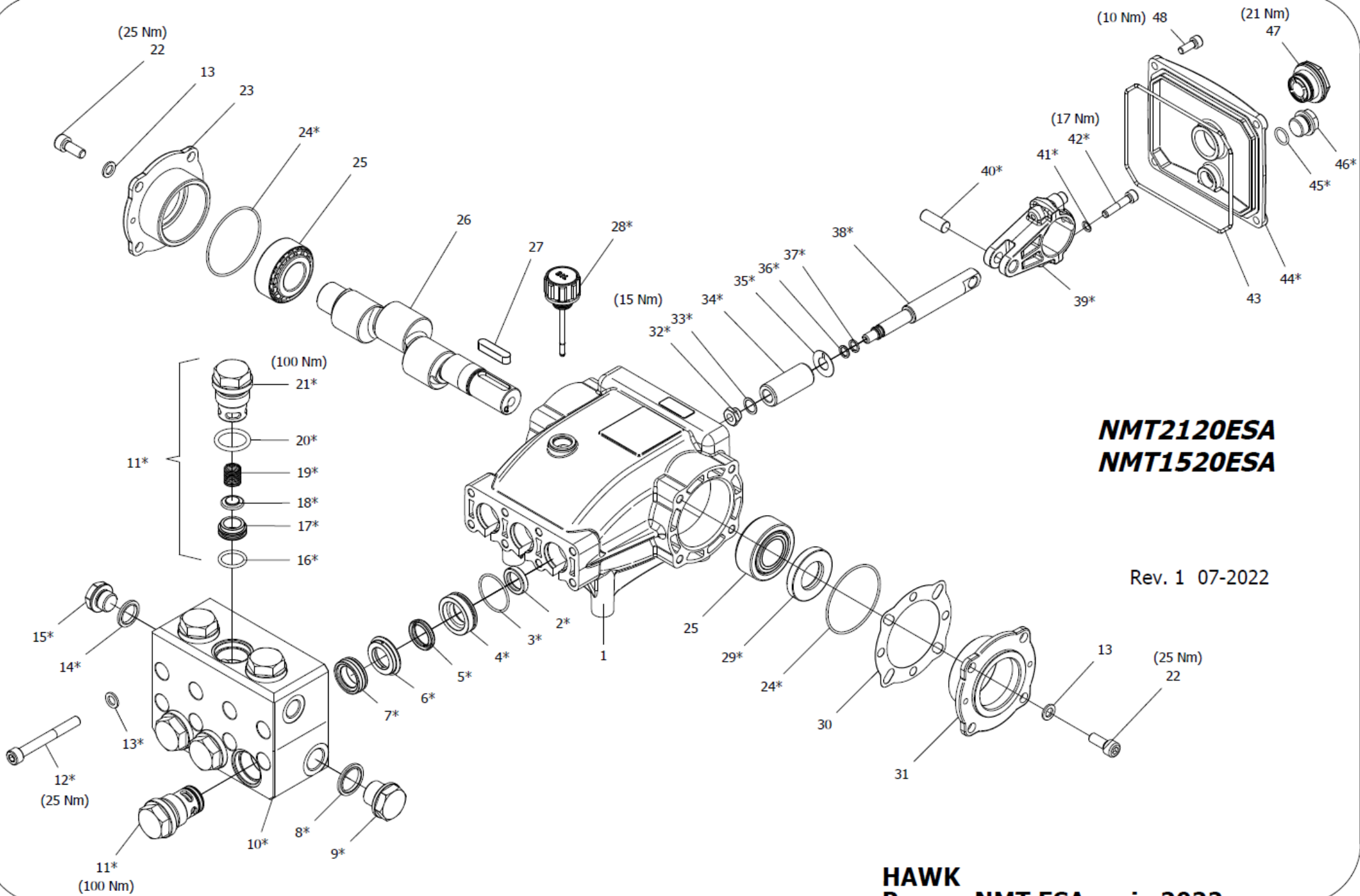

**NMT2120ESA
NMT1520ESA**

Rev. 1 07-2022

**HAWK
Pompe NMT ESA serie 2022
NMT ESA Pumps 2022 series**

NMT ESA 2022 SERIES

ORDINARY MAINTENANCE KIT / KIT MANUTENZIONE ORDINARIA

KIT	Item Pos.	Part Number Codice	Description	Descrizione	Q.TY by Pump Q.TA per Pompa	NMT2120ESA	NMT15120ES
A	3- 4- 5- 7	1.905-016.0	PLUNGER SEALS DIA. 20 mm	GUARNIZIONI PISTONE Ø20	1	•	
B	11 (16 - 17 - 18 - 19 - 20 - 21)	1.905-056.0	COMPLETE VALVE	VALVOLA COMPLETA	1		

EXTRAORDINARY MAINTENANCE KIT / KIT MANUTENZIONE STRAORDINARIA

KIT	Item Pos.	Part Number Codice	Description	Descrizione	Q.TY by Pump Q.TA per Pompa	NMT2120ESA	NMT1520ESA
C	3- 4- 5- 6- 7	1.905-017.0	COMPLETE SEALS PACKING DIA. 20 mm	PACCO COMPLETO GUARNIZIONI PISTONE Ø20	1	•	
D	32 - 33- 34- 35 36- 37	1.905-018.0	PLUNGER DIA. 20 mm	PISTONE Ø20	3		
E	2	1.904-806.0	PLUNGER OIL SEALS	ANELLI TENUTA OLIO ASTA	1		
F	24- 29- 43 - 45 - 46- 47	1.905-542.0	KIT CRANKCASE SEALS	KIT TENUTE CARTER	1		
G	3 - 4 - 5 - 6 - 7 - 8 - 9 - 10 - 11 (16 - 17 - 18 - 19 - 20) 12 - 13 - 14 - 15	1.905-019.0	COMPLETE MANIFOLD	TESTATA COMPLETA	1		
H	33- 34- 37 38- 39- 40 41- 42- 43	1.905-020.0	CONNECTING ROD PLUNGER ROD ASSY	PREMONTATO ASTA-BIELLA PISTONE	3		

“Q.TY by Pump” => Necessary quantity to repair one pump
 “Q.TA’ per Pompa” => Quantità necessaria per riparare una pompa

OPTIONAL

TOOL KIT

<i>Part Number Codice</i>	<i>Description</i>	<i>Descrizione</i>	<i>Q.TY by Pump Q.TA per Pompa</i>	<i>NMT2120ESA</i>	<i>NMT1520ESA</i>
1.099-667.0	TOOL-KIT	TOOL-KIT	1		
1.904-414.0	OIL SEAL EXTRACTOR TOOL-KIT	TOOL-KIT ESTRAZIONE PARAOLIO	1		•



IMPORTANT

IMPORTANTE

*** Part available ONLY in kit
Disponibile SOLO in kit**

**(...) Parts pre-assembled
Parti pre-assemblate**

PARTS LIST LISTA PARTI

Item Pos	Part Number Codice	Description	Descrizione	KIT	Q.TY Q.TÀ	NMT120ESA	NMT1520ESA
1	9.851-881.0	CRANKCASE	CARTER		1		
2*		PLUNGER OIL SEAL	ANELLO RADIALE	E	3		
3*		"O" RING Ø1.78X31.47EPDM	"O" RING Ø1.78X31.47 EPDM	A-C-G	3		
4*		PRESSURE RING 20MM	PRESSORE "U" Ø20	A-C-G	3		
5*		LOW PRESSURE "U" SEAL, DIA.20MM	ANELLO TENUTA "U" Ø20	A-C-G	3		
6*		INTERMED. RING 20MM	DIFFUSORE INTER. Ø20	C-G	3		
7*		HIGH PRESSURE "U" SEAL, DIA.20MM	ANELLO TENUTA "U" Ø20	A-C-G	3		
8*		BONDED SEAL G1/2 STAINLESS STEEL	BONDED SEAL G 1/2 INOX	G	1		
9*		PLUG G1/2 STAINLESS STEEL	TAPPO G1/2 INOX	G	1		
10*		MANIFOLD HOUSING STAINLESS STEEL	TESTATA INOX	G	1		
11*		VALVE ASSEMBLY	VALVOLA PREMONTATA	B-G	6		
12*		SCREW M8x70 UNI5931 INOX A2 70	VITE TCEI M8x70 UNI5931 INOX A2 70	G	8		
13*		WASHER Ø8,5 STAINLESS STEEL	ROSETTA Ø8.5 INOX	G	16		
14*		BONDED SEAL G3/8 STAINLESS STEEL	BONDED SEAL G 3/8 INOX	G	1		
15*		PLUG G3/8 STAINLESS STEEL	TAPPO G3/8 INOX	G	1		
16*		O-RING 3075 Ø2,62x18,72 FKM	O-RING 3075 Ø2,62x18,72 FKM	B-G	6		
17*		VALVE SEAT	SEDE VALVOLA	B-G	6		
18*		VALVE PLATE	PIATTELLO VALVOLA	B-G	6		
19*		VALVE SPRING	MOLLA VALVOLA	B-G	6		
20*		O-RING Ø3,53x23,39 FKM	O-RING Ø3,53x23,39 FKM	B-G	6		
21*		CAP VALVE NMT ESA	TAPPO VAM NMT ESA	B-G	6		
22*	9.851-476.0	SCREW M8x20 UNI5931 INOX A2 70	VITE TCEI M8x20 UNI5931 INOX A2 70		8		
23	9.850-639.0	FLANGIA CHIUSA ROSSA	RED CLOSED BEARING HOUSING		1		
24*		"O" RING Ø1.78X60.05	"O" RING Ø1.78X60.05	F	2		
25	9.850-349.0	ROLLER BEARING 33205	CUSCINETTO A RULLI 33205		2		
26	9.850-179.0	SINGLE - ENDED SHAFT ECC 8.25	ALBERO SEMPLICE P.D.F. ECC 8.25		1		
	9.850-177.0	SINGLE - ENDED SHAFT ECC 6	ALBERO SEMPLICE P.D.F. ECC 6				
27	9.850-446.0	CRANKSHAFT KEY	CHIAVETTA		1		
28	9.851-286.0	OIL DIP STICK	TAPPO LIVELLO OLIO		1		
29*		CRANKSHAFT SEAL	ANELLO RADIALE	F	1		
30	9.850-547.0	SHIM	DISTANZIALE		1		
31	9.850-638.0	FLANGIA ROSSA	RED BEARING HOUSING		1		
32		PLUNGER NUT STAINLESS STEEL	DADO PISTONE INOX	D-H	3		
33*		SPACER Ø 11.2/15X0.5 STAINLESS STEEL	ROSETTA Ø 1.2/15X0.5 INOX	D-H	3		
34*		PLUNGER 20MM	PISTONE Ø20	D	3		
35*		SPACER Ø 11.3/24X0.5 STAINLEES STEEL	ROSETTA Ø 1.3/24X0.5 INOX	D	3		
36*		O-RING 2031 - Ø1,78x7,66 EPDM	O-RING 2031 - Ø1,78x7,66 EPDM	D-H	3		

Item Pos	Part Number Codice	Description	Descrizione	KIT	Q.TY Q.TÀ	NMT2120ESA	NMT1520ESA
37*		TEFLON RING	ANELLO ANTIESTRUSIONE	D-H	3		
38*		PLUNGER ROD STAINLESS STEEL	ASTA PISTONE INOX	H	3		
39*		CONNECTING ROD	BIELLA	H	3		
40*		CONNECTING ROD PIN	SPINOTTO	H	3		
41*		SPRING WASHER Ø6	ROSETTA ELASTICA Ø6	H	6		
42*		CONNECTING ROD SCREW M6X30	VITE M6X30	H	6		
43*		"O" RING Ø 2.62X126.67	"O" RING Ø 2.62X126.67	F	1		
44*	9.853-776.0	RED CRANKCASE COVER	COPERCHIO POSTERIORE ROSSO		1		
45		"O" RING Ø1.78X14	"O" RING Ø1.78X14	F	1		
46*		BRASS PLUG G 3/8	TAPPO G 3/8	F	1		
47*		SIGHT GLASS, G3/4	SPIA LIVELLO OLIO G3/4	F	1		
48*	9.851-475.0	COVER SCREW M6X16 STAINLESS STEEL	VITE M6X16 INOX A2 70		4		

