

## NHDP ESA – 200 BAR

### Caratteristiche Tecniche

### Albero maschio – Solid shaft

### Technical Characteristics

Pump Pompa	Pressure Pressione		Volume Portata				RPM giri/min		Power Potenza			
			l/min		GPM				HP		kW	
	bar	PSI	50 Hz	60 Hz	50 Hz	60 Hz	50 Hz	60 Hz	50 Hz	60 Hz	50 Hz	60 Hz
NHDP8520ESA	200	2900	8.5	10.1	2.2	2.7	1450	1740	4.3	5.1	3.2	3.9
NHDP1120ESA	200	2900	11	13.2	2.9	3.5	1450	1740	5.7	6.8	4.3	5.1

### Dimensioni d'ingombro

### Overall dimensions

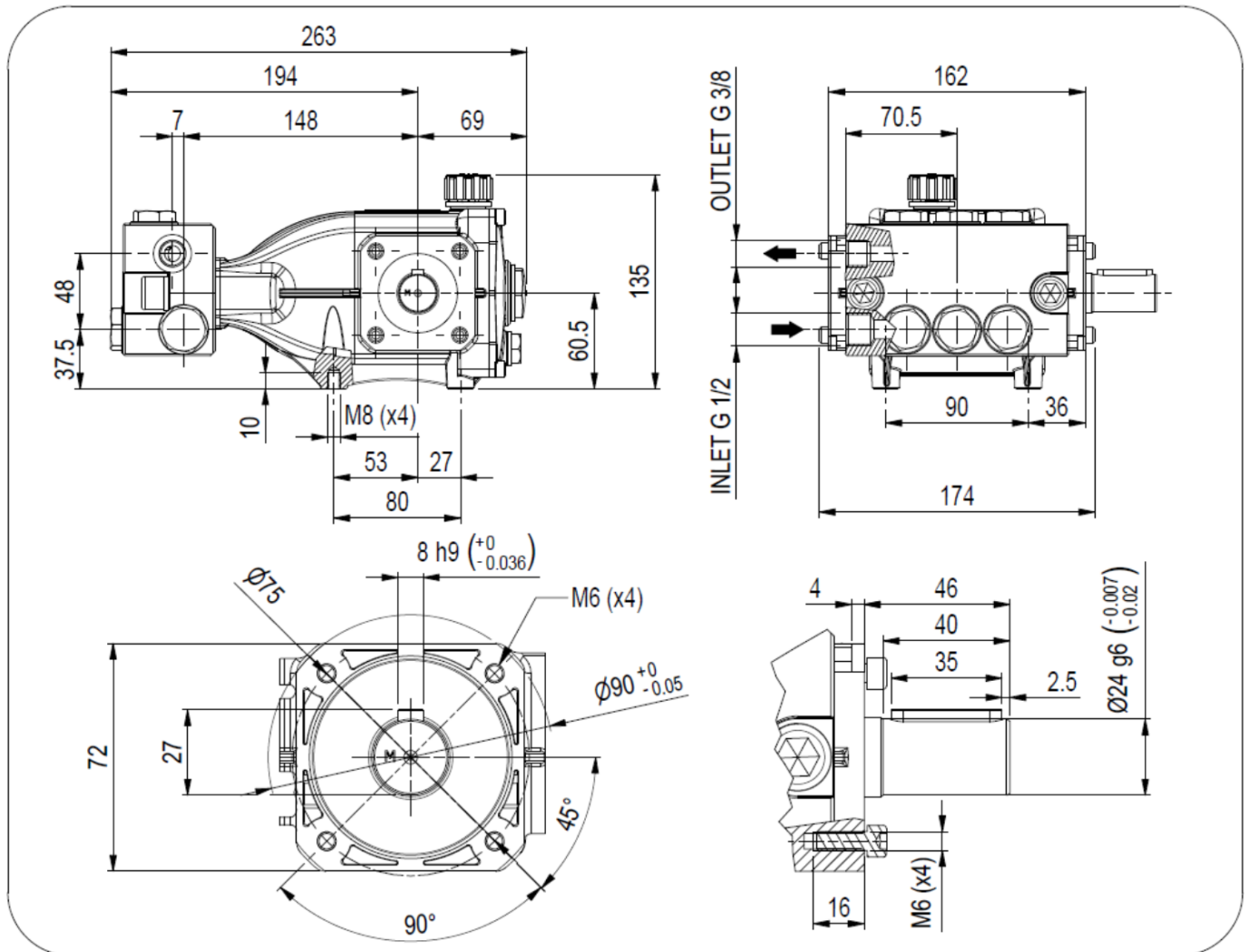

Lubrificazione: Olio SAE 10W40  
 Capacità: 0.4 Litri  
 Peso pompa: 8.2 kg

Lubrication: SAE 10W40 Oil  
 Capacity: 0.4 Litres  
 Weight: 8.2 kg

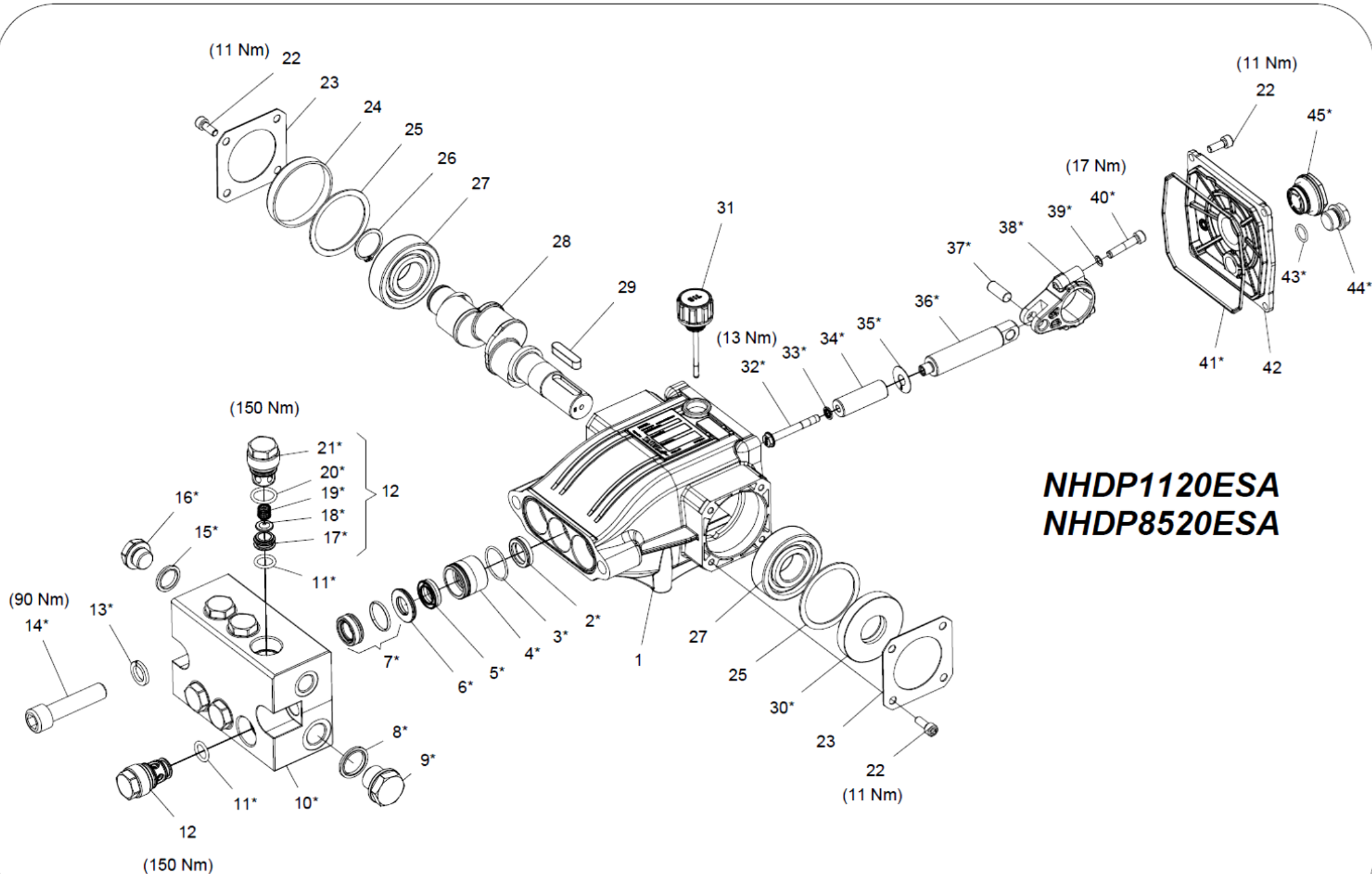

**NHDP1120ESA**  
**NHDP8520ESA**

**HAWK**  
**Pompe Serie NHD PLUS ESA 2024**  
**NHD PLUS ESA Pumps 2024 Serie**

## NHDP ESA 2022 SERIES

### ORDINARY MAINTENANCE KIT / KIT MANUTENZIONE ORDINARIA

KIT	Item Pos.	Part Number Codice	Description	Descrizione	Q.TY by Pump Q.TA per Pompa	NHDP8520ESAR/L	NHDP1120ESAR/L
A	4 - 6- 8- 15	1.905-097.0	PLUNGER SEALS DIA. 16 mm OR EPDM (NHDP ESA)	KIT GUARNIZIONI DIA.16 mm OR EPDM (NHDP ESA)	1		
B	13 (18 -19 - 20 - 21 - 22)	1.905-095.0	COMPLETE VALVE NHDP EBCH/ES	KIT VAM COMPLETA NHDP EBCH/ES	1	•	•

### EXTRAORDINARY MAINTENANCE KIT / KIT MANUTENZIONE STRAORDINARIA

KIT	Item Pos.	Part Number Codice	Description	Descrizione	Q.TY by Pump Q.TA per Pompa	NHDP8520ESAR/L	NHDP1120ESAR/L
C	4- 5- 6- 7 - 8 - 17	1.905-098.0	COMPLETE PACKING SEALS DIA. 16 mm OR EPDM (NHDP ESA)	KIT GUARNIZIONI COMPL. "U" Ø16 OR EPDM (NHDP ESA)	1		
D	34 - 35- 36- 37	1.099-738.0	PLUNGER DIA. 16 mm	PISTONE Ø16	3		
E	3	1.099-740.0	PLUNGER OIL SEALS	ANELLI TENUTA OLIO ASTA	1		
F	17 - 25 - 31 - 42 - 44 - 45	1.905-624.0	KIT CRANKCASE SEALS	KIT TENUTE CARTER	1	•	•
G	4 - 5 - 6 - 7 - 8 - 9 - 10 - 11 - 12 - 13 (18 - 19 - 20 - 21 - 22) - 16 - 17	1.905-096.0	NHDP Ø16 COMPLETE MANIFOLD	KIT TESTATA COMPLETA NHDP ESA Ø16	1		
H	39 - 40- 41- 42 - 43	1.905-742.0	CONNECTING ROD PLUNGER ROD ASSY	PREMONTATO ASTA-BIELLA PISTONE	3		

“Q.TY by Pump” => Necessary quantity to repair one pump  
 “Q.TA’ per Pompa” => Quantità necessaria per riparare una pompa

## TOOL KIT

<i>Part Number Codice</i>	<i>Description</i>	<i>Descrizione</i>	<i>Q.TY by Pump Q.TÀ per Pompa</i>	<i>NHDP8520ESAR/L</i>	<i>NHDP1120ESAR/L</i>
1.905-137.0	TOOL-KIT ORDINARIO NHDP EBCH/ES	TOOL-KIT NHDP EBCH/ES	1	•	•
1.905-591.0	TOOL-KIT EXTRAORDINARY	TOOL-KIT MANUTENZIONE STRAORINARIA	1		

### **IMPORTANT**

### **IMPORTANTE**

**\*** *Part available ONLY in kit*  
Disponibile SOLO in kit

**(...)** *Parts pre-assembled*  
Parti pre-assemblate

## PARTS LIST LISTA PARTI

Item Pos	Part Number Codice	Description	Descrizione	KIT	Q.TY Q.T A	NHDP8520ESAR/L	NHDP1120ESAR/L
1	9.854-036.0	RED CRANKCASE	CARTER ROSSO HAWK		1		
2*		PLUNGER OIL SEAL	ANELLO RADIALE	E	3		
3*		"O" RING Ø1.78X26.7 EPDM	"O" RING Ø1.78X26.7 EPDM	A-C-G	3		
4*		PRESSURE RING DIA. 16 MM	PRESSORE "U" Ø16	C-G	3		
5*		SEALING RING Ø16X24X8 "U" PTFE	AN. TENUTA PIST. Ø16X24X8 PTFE	A-C-G	3		
6*		RING AISI 316	DIFFUSORE AISI 316	C-G	3		
7*		SEALING RING Ø16X26X9,5 "U" PTFE	AN. TENUTA PIST. Ø16X26X9,5 "U" PTFE	A-C-G	3		
8*		AISI 316 WASHER SEAL G1/2	BONDED SEAL G1/2 AISI 316	G	1		
9*		INOX 316 PLUG G1/2	TAPPO G1/2 INOX 316	G	1		
10*		AISI 316 CYLINDERHEAD	TESTATA AISI 316 NHDP	G	1		
11*		O-RING 2062 - Ø1,78X15,60 EPDM	O-RING 2062 - Ø1,78X15,60 EPDM	B-G	6		
12*		AISI 316 VALVE ASSEMBLY	VALVOLA PREMONTATA AISI 316	B-G	6		
13*		LOCK-WASHER AISI316	ROSETTA ELASTICA Ø14 A4	G	2		
14*		A4 MANIFOLD STUD BOLT M14X60	VITE TCEI M14X60 A4	A-G-C	2	•	•
15*		BONDED SEAL G3/8 AISI 316	BONDED SEAL G3/8 AISI 316	G	1		
16*		AISI 316 PLUG G 3/8	TAPPO G 3/8 AISI316	F-G	1		
17*		VALVE SEAT	SEDE VALVOLA	B-G	6		
18*		VALVE PLATE	PIATTELLO VALVOLA	B-G	6		
19*		VALVE SPRING	MOLLA VALVOLA	B-G	6		
20*		O-RING 617 - Ø2,62X17,86 EPDM	O-RING 617 - Ø2,62X17,86 EPDM	B-G	6		
21*		AISI 316 CAP VALVE	TAPPO VAM AISI 316 NHDP ESA	B-G	6		
22*	9.851-475.0	SCREW M6X16 AISI 316	VITE TCEI M6X16 AISI 316		12		
23*	9.854-038.0	BEARING COVER AISI 316	COPERCHIO CUSCINETTO AISI 316		2		
24*		BEARING SEAL	CAPPELLOTTO CUSCINETTO	F	1		
25*	9.850-554.0	CRANKSHAFT SEAL SPACER	DISTANZIALE PARAOLIO ALBERO		2		
26	9.851-198.0	SNAP RING DIA. 25 MM	ANELLO Ø25		1		
27	9.850-460.0	BALL BEARING	CUSCINETTO A SFERE		2		
28	9.850-225.0	SINGLE-ENDED SHAFT	ALBERO SEMPLICE P.D.F		1		•
	9.850-226.0	SINGLE-ENDED SHAFT	ALBERO SEMPLICE P.D.F		1	•	
29	9.850-446.0	CRANKSHAFT KEY	CHIAVETTA		1		
30*		CRANKSHAFT SEAL	ANELLO RADIALE	F	1	•	•
31	9.851-286.0	OIL DIP STICK	TAPPO LIVELLO OLIO		1		
32*		PLUNGER BOLT	VITE PISTONE	D	3		

33	Part Number Codice	Description	Descrizione	KIT	Q.TY Q.T A	NHDP8520ESAR/L	NHDP1120ESAR/L
33*		BONDED SEAL - Ø6,7X11X1 AISI 304	BONDED SEAL - Ø6,7X11X1 AISI 304	D	3		
34*		PLUNGER DIA. 16 MM	PISTONE Ø16	D	3		
35*		COPPER SPACER	ROSETTA RAME	D	3		
36*		PLUNGER ROD	ASTA PISTONE	H	3		
37*		CONNECTING ROD PIN	SPINOTTO	H	3		
38*		CONNECTING ROD	BIELLA	H	3		
39*		SPRING WASHER DIA. 6 MM	ROSETTA SCHNORR Ø6	H	6		
40*		CONNECTING ROD SCREW	VITE M6X30	H	6		
41*		"O" RING Ø2.62X111.62	"O" RING Ø2.62X111.62	F	1		
42	9.854-035.0	RED CRANKCASE COVER	COPERCHIO POST. ROSSO HAW		1		
43		"O" RING Ø1.78X14	"O" RING Ø1.78X14	F	1		
44*		TAPPO OTTONE G3/8	BRASS PLUG	F	1		
45*		SIGHT GLASS G3/4	SPIA LIVELLI OLIO G3/4	F	1		