

# NHD – 120 BAR

Caratteristiche Tecniche

IEC 90 – 100 - 112

Technical Characteristics

Pump Pompa	Pressure Pressione		Volume Portata				RPM giri/min		Power Potenza			
			l/min		GPM				HP		kW	
	bar	PSI	50 Hz	60 Hz	50 Hz	60 Hz	50 Hz	60 Hz	50 Hz	60 Hz	50 Hz	60 Hz
NHD8512C1	120	1740	8.5	10.1	2.2	2.7	1450	1740	2.6	3.1	1.9	2.3
NHD8512C	120	1740	8.5	10.1	2.2	2.7	1450	1740	2.6	3.1	1.9	2.3
NHD1012C	120	1740	10	12	2.6	3.2	1450	1740	3.0	3.6	2.2	2.6
NHD1112C	120	1740	11	13.2	2.9	3.5	1450	1740	3.4	4.1	2.5	3.0
NHD1212C	120	1740	12	14	3.1	3.7	1450	1740	3.6	4.4	2.7	3.2

Dimensioni d'ingombro

Overall dimensions

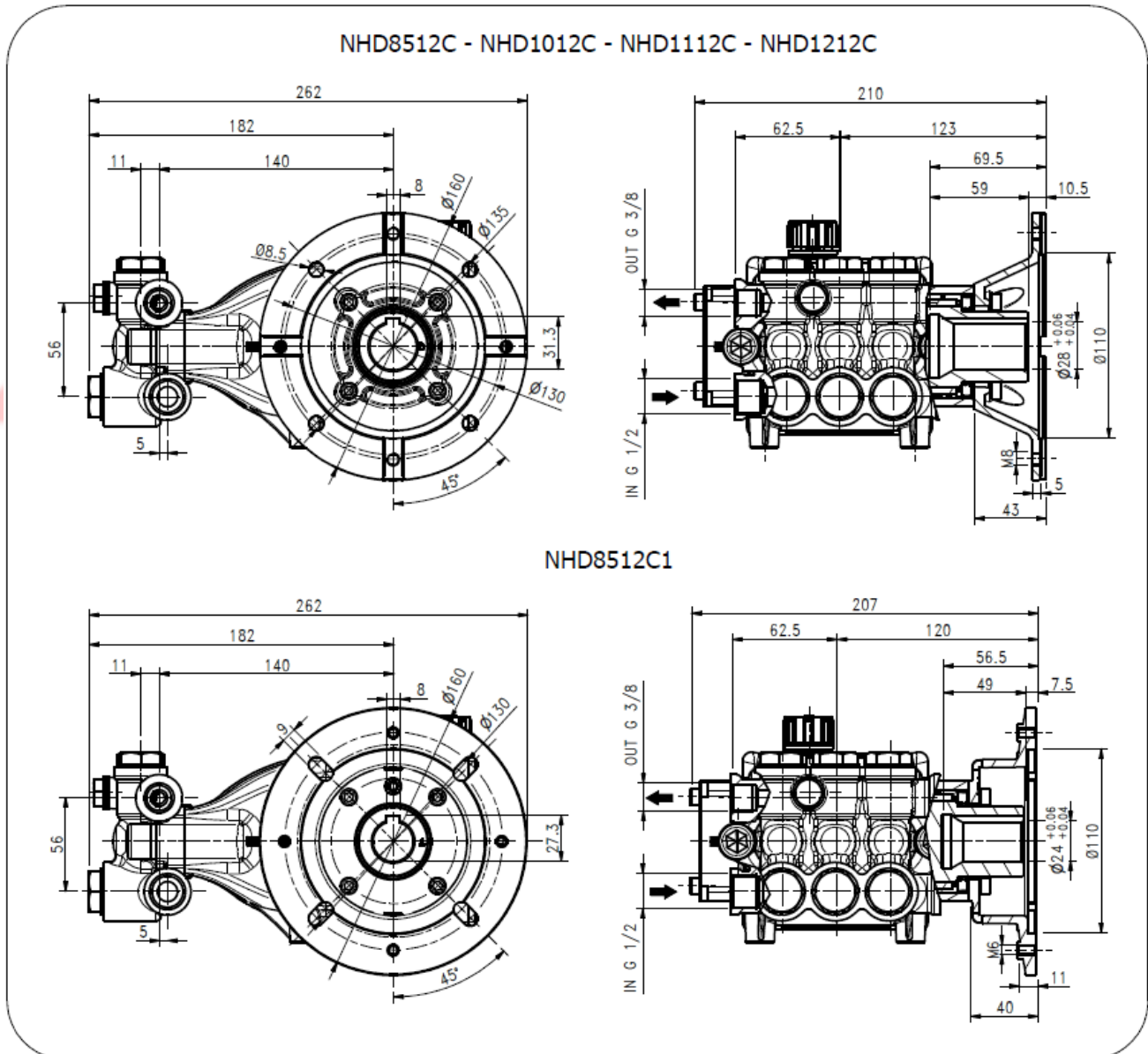

Lubrificazione: Olio SAE 10W40  
 Capacità: 0.4 Litri  
 Peso pompa: 7.7kg

Lubrication: SAE 10W40 Oil  
 Capacity: 0.4 Litres  
 Weight: 7.7 kg



## NHD C 2014 SERIES

### ORDINARY MAINTENANCE KIT / KIT MANUTENZIONE ORDINARIA

KIT	Item Pos.	Part Number Codice	Description	Descrizione	Q.TY by Pump Q.TA per Pompa	NHD8512C1R/L	NHD8512CR/L	NHD1012CR/L	NHD1112CR/L	NHD1212CR/L
A	2- 4- 5- 6- 7- 8 9- 19	1.905-668.0	PLUNGER SEALS DIA. 16 mm	GUARNIZIONI PISTONE Ø16	1					
B	13- 14 (23- 24 25- 26) 15	1.905-617.0	COMPLETE VALVE	VALVOLA COMPLETA	1	•	•	•	•	•

### EXTRAORDINARY MAINTENANCE KIT / KIT MANUTENZIONE STRAORDINARIA

KIT	Item Pos.	Part Number Codice	Description	Descrizione	Q.TY by Pump Q.TA per Pompa	NHD8512C1R/L	NHD8512CR/L	NHD1012CR/L	NHD1112CR/L	NHD1212CR/L
C	42- 43- 44- 45	1.099-738.0	PLUNGER DIA. 16 mm	PISTONE Ø16	3					
D	3	1.099-740.0	PLUNGER OIL SEALS	ANELLI TENUTA OLIO ASTA	1					
E	22- 29- 36 50- 52- 53	1.905-622.0	KIT CRANKCASE SEALS	KIT TENUTE CARTER	1					
F	2- 4- 5- 6 7- 8- 9- 10- 11 12- 13- 14 (23 24- 25- 26) 15- 16- 17- 18 19- 20- 21- 22	1.099-741.0	COMPLETE MANIFOLD	TESTATA COMPLETA	1	•	•	•	•	•
G	40- 46- 47 48- 49	1.904-183.0	CONNECTING ROD PLUNGER ROD ASSY	PREMONTATO ASTA-BIELLA PISTONE	3					
H	15- 16	1.904-249.0	VALVE PLUG ASSY	PREMONTATO TAPPO VAM	6					

“Q.TY by Pump” => Necessary quantity to repair one pump  
 “Q.TA’ per Pompa” => Quantità necessaria per riparare una pompa

### OPTIONAL

Item Pos.	Part Number Codice	Description	Descrizione	Q.TY by Pump Q.TA per Pompa	NHD8512C1R/L	NHD8512CR/L	NHD1012CR/L	NHD1112CR/L	NHD1212CR/L
54	9.853-424.0	THREADED BRASS PLUG G1/4	PREMONTATO TAPPO FORATO	1	•	•	•	•	•

### TOOL KIT

Part Number Codice	Description	Descrizione	Q.TY by Pump Q.TA per Pompa	NHD8512C1R/L	NHD8512CR/L	NHD1012CR/L	NHD1112CR/L	NHD1212CR/L
1.099-668.0	TOOL-KIT	TOOL-KIT	1	•	•	•	•	•
1.905-591.0	OIL SEAL EXTRACTOR TOOL-KIT	TOOL-KIT ESTR. PARAOLIO	1	•	•	•	•	•

### IMPORTANT

### IMPORTANTE

\* Part available ONLY in kit  
Disponibile SOLO in kit

(...) Parts pre-assembled  
Parti pre-assemblate

### PARTS LIST LISTA PARTI

Item Pos	Part Number Codice	Description	Descrizione	KIT	Q.TY Q.TÀ	NHD8512C1R/L	NHD8512CR/L	NHD1012CR/L	NHD1112CR/L	NHD1212CR/L
1	9.850-369.0	CRANKCASE	CARTER		1					
2*		"O" RING Ø1.78X74.5	"O" RING Ø1.78X74.5	A-F	1					
3*		PLUNGER OIL SEAL	ANELLO RADIALE	D	3					
4*		"O" RING Ø1.78X26.7	"O" RING Ø1.78X26.7	A-F	3					
5*		PRESSURE RING WASHER DIA. 16 MM	RONDELLA PRESSORE Ø16	A-F	3					
6*		"U" SEAL, DIA. 16 MM	ANELLO TENUTA "U" Ø16	A-F	3					
7*		PRESSURE RING DIA. 16 MM	PRESSORE "V" Ø16	A-F	3					
8*		"V" SEAL, DIA. 16 MM	ANELLO TENUTA "V" Ø16	A-F	3					
9*		SUPPORT RING DIA. 16 MM	DIFFUSORE Ø16	A-F	3					
10*		COPPER WASHER G1/2	GUARNIZIONE RAME G1/2	F	1					
11*		BRASS PLUG G1/2	TAPPO OTTONE G1/2	F	1					
12*		MANIFOLD HOUSING	TESTATA	F	1					
13*		"O" RING Ø1.78X15.6	"O" RING Ø1.78X15.6	B-F	6					
14*		VALVE ASSEMBLY	VALVOLA PREMONTATA	B-F	6					
15*		"O" RING Ø1,78X18.77	"O" RING Ø1.78X18.77	B-F-H	6					
16*		VALVE PLUG	TAPPO VALVOLA	F-H	6					
17*		BRASS PLUG G1/4	TAPPO OTTONE G1/4	F	1	•	•	•	•	•
18*		COPPER WASHER G1/4	GUARNIZIONE RAME G1/4	F	1					
19*		MANIFOLD STUD BOLT M14X40	VITE TCEI M14X40	A-F	2					
20*		LOCK-WASHER	ROSETTA ELASTICA Ø14	F	2					
21*		COPPER WASHER G3/8	GUARNIZIONE RAME G 3/8	F	1					
22*		BRASS PLUG G 3/8	TAPPO OTTONE G 3/8	F-E	2					
23*		VALVE SEAT	SEDE VALVOLA	B-F	6					
24*		VALVE PLATE	PIATTELLO VALVOLA	B-F	6					
25*		VALVE SPRING	MOLLA VALVOLA	B-F	6					
26*		VALVE CAGE	GABBIA VALVOLA	B-F	6					
27	9.851-474.0	SCREW M6X16	VITE TCEI M6X16		8					
28	9.850-379.0	BEARING COVER	COPERCHIO CUSCINETTO		1					
29*		BEARING SEAL	CAPPELLOTTO CUSCINETTO	E	1					
30	9.850-554.0	CRANKSHAFT SEAL SPACER	DISTANZIALE PARAOLIO ALBERO		1					
31	9.851-198.0	SNAP RING DIA. 25 MM	ANELLO Ø25		1					
32	9.850-460.0	BALL BEARING	CUSCINETTO A SFERE		1					
33	9.850-223.0	HOLLOW SHAFT	ALBERO CAVO Ø28		1		•			
	9.850-234.0	" "	" " "		1			•		
	9.850-235.0	" "	" " "		1				•	
	9.850-236.0	" "	" " "		1					•
	9.851-989.0	" "	" " "		1	•				

Item Pos	Part Number Codice	Description	Descrizione	KIT	Q.TY Q.TA	NHD8512C1R/L	NHD8512CR/L	NHD1012CR/L	NHD1112CR/L	NHD1212CR/L
34	9.851-286.0	OIL DIP STICK	TAPPO LIVELLO OLIO		1					
35	9.850-354.0	NEEDLE ROLLER BEARING	CUSCINETTO A RULLINI		1					
36*		CRANKSHAFT SEAL	ANELLO RADIALE	E	1	•	•	•	•	•
37	9.851-504.0	HEXAGONAL SCREW M8X25	VITE TE M8X25		4					
38	9.851-114.0	WASHER DIA. 8,5 MM	ROSETTA Ø8,5		4					
39	9.850-631.0	MOTOR FLANGE	FLANGIA MOTORE		1	•				
	9.850-632.0	“ “	“ “		1		•	•	•	•
40*		SPRING WASHER DIA. 6 MM	ROSETTA SCHNORR Ø6	G	10					
41	9.851-491.0	SCREW M6X20	VITE TCEI M6X20		4					
42*		PLUNGER BOLT	VITE PISTONE	C	3					
43*		BONDED SEAL - Ø6,7X11X1 AISI 304	BONDED SEAL - Ø6,7X11X1 AISI 304	C	3					
44*		PLUNGER DIA. 16 MM	PISTONE Ø16	C	3					
45*		COPPER SPACER	ROSETTA RAME	C	3					
46*		PLUNGER ROD	ASTA PISTONE	G	3					
47*		CONNECTING ROD PIN	SPINOTTO	G	3	•	•	•	•	•
48*		CONNECTING ROD	BIELLA	G	3					
49*		CONNECTING ROD SCREW	VITE M6X30	G	6					
50*		"O" RING Ø2.62X111.62	"O" RING Ø2.62X111.62	E	1					
51	9.850-392.0	CRANKCASE COVER	COPERCHIO POSTERIORE		1					
52*		"O" RING Ø1.78X14	"O" RING Ø1.78X14	E	1					
53*		SIGHT GLASS G3/4	SPIA LIVELLI OLIO G3/4	E	1					